

TO BE HANDED OVER ON RELIEF

# NATIONAL CADET CORPS



## STANDING INSTRUCTIONS VOL I & II

Directorate General of NCC  
Ministry of Defence  
RK Puram New Delhi 110066

By Order  
Director General NCC

## FOREWORD

1. NCC plays a vital role in growth and development of country by grooming its most precious resource, the youth. In order to attain our national goals it is imperative that our training encapsulates and embeds the qualities and attributes in our cadets.
2. For NCC cadets, Camps are the most exciting and meaningful part of training, wherein cadets get exposure to the merits of NCC. Camps are organized at various levels i.e. Unit, Group HQ, Directorate and Republic Day (RD) Camp. These Camps serve to motivate the young students. NCC must conduct the Camps in an ingenious, pragmatic, transparent, flawless and efficient manner at all levels. A large number of dignitaries visit NCC Republic Day Camp an annual event for the NCC Cadets held at HQ DG NCC Camp at Delhi Cantonment. During this Camp Inter Directorate Competitions are conducted which contribute towards the award of prestigious Republic Day Banner. For such a prestigious Camp it is must that modalities for conduct of the competition be well defined. This book has been compiled in two volumes to achieve this aim.
3. Volume I of Standing Instructions lays down the detailed organization of RD Camp, norms of administration and details of training to be carried out during RD Camp. The duties of NCC Directorates, Camp Appointments, Officers & Cadets has been worked out based on the experience and good practices.
4. Volume II of Standing Instructions lays down detailed rules for conduct of all Inter Directorate Competitions in NCC.
5. While the last edition of Volume I was published in 1994, Volume II was issued in 2010. Various changes & modification have been done due to environment realities, feedback received & aspiration of the cadets, which yielded in positive dynamism in the organisation. There was a felt need to compile these modifications and produce an updated Standing Instruction (Red Book).
6. I am confident that this new edition of Red Book will serve to guide all in conduct of competitions and make NCC Republic Day Camp a professionally executed event.

Jai Hind

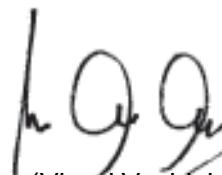

(Vinod Vashisht)  
Lt Gen  
Director General NCC

New Delhi  
15 April 2017

**STANDING INSTRUCTIONS ON ANNUAL NCC  
REPUBLIC DAY CAMP AT DELHI CANTT**

**VOLUME – I**

**INDEX**

**CHAPTER I**

**STANDING INSTRUCTIONS ON ANNUAL RD CAMP**

<b>Subject</b>	<b>Page No</b>
Part I General	3
Part II Preparation for the Camp and Charter of Duties	6
Part III –Camp Staff	7
Part IV Directorate RD Contingents	8
Part V- Discipline and Security	14
Part VI – Communications	18
Part VII – Miscellaneous	20
<b>Appendix A</b> - Responsibility, coord and conduct of Major Events	22
<b>Appendix B</b> - SOP: Camp Inauguration	23
<b>Appendix C</b> - SOP: Visit of Dignitaries	26
<b>Appendix D</b> - SOP: Tea Reception at official residences of Service Chiefs & DG NCC	28
<b>Appendix E</b> - SOP: Reception at Rashtrapati Bhawan	29
<b>Appendix F</b> - Camp routine	33
<b>Appendix G</b> - Composition and duties of NCC Republic Day Camp Standing Committee	34
<b>Appendix H</b> - Responsibilities of various Dtes, Appointments at NCC RDC	37
<b>Appendix J</b> - List of Contingent Stores, Equipment to be brought by Contingents & Cadets	52
<b>Appendix K</b> - Sequence of actions on arrival at RD Camp & Duties of Contingent Commanders	57
<b>Appendix L</b> - SOP for Reception, Ushering and seating arrangement for functions connected with NCC RD Camp, PMs Rally, Cultural Shows And Horse Show	61

## CHAPTER II

### GENERAL INSTRUCTIONS ON ADMINISTRATION, FUNDS AND ACCOUNTS

Subject	Page No
Part I – Administration	68
Part II – Funds and Accounts	87
<b>Appendix A</b> – SOP Hygiene and sanitation	90
<b>Appendix B</b> – Daily Ration Expenditure Statement	94
<b>Appendix C</b> – SOP Cook House	95
<b>Appendix D</b> – Transport requisition format	98
<b>Appendix E</b> – SOP – CSD	99
<b>Appendix F</b> – SOP – Shopping Complex	102
<b>Appendix G</b> – SOP – Management of Kote	104
<b>Appendix H</b> – Establishment of Reception Centre RDC	106
<b>Appendix J</b> – SOP of Fire Fighting	118
<b>Appendix K</b> – Duty Officer Form	112
<b>Appendix L</b> – Establishment of Photo shop	115
<b>Appendix M</b> – SOP on Fund Management	118

## CHAPTER III

### TRAINING, MAJOR EVENTS, PM RALLY AND FOREIGN CADETS

Subject	Page No
Part I - Training	123
Part II - Major Events	124
Part III - Prizes, Trophies, Certificates & their distribution	126
Part IV - PM's Rally	128
Part V - Conduct and Adm of Foreign Cadets	131
<b>Appendix A</b> - Procedure and layout of Guard of Honour	134
<b>Appendix B</b> – Recommended programme of Horse Show & Band Display	136
<b>Appendix C</b> - Summary of the prizes required for RDC & Responsibilities of OIC	138
<b>Appendix D</b> - Detailed duties of conducting Camp Staff for Foreign Cadets	143

### **Camp strength**

4. The camp strength as approved is 2070 cadets. Any increases will be got approved from Govt. of India every year by secretary RDC (Director Training B) by 01 Aug. Foreign cadets also attend the camp from 14 Jan onwards. Camp staff will be in addition to this.

### **Venue and layout of the camp**

5. Camp is held at garrison parade ground, Delhi Cantt.

### **Major events and responsibilities for coordination**

6. Secretary, RD cell prepares schedule of Major events by 10 Aug and the same is issued, after approval of director general, to all concerned to facilitate planning at all levels.

### **Standing operating procedure for special functions**

7. Standing operating procedure laying down responsibilities for organizing and detailed programme for the following special functions are as under:-

- |     |  |                     |
|-----|--|---------------------|
| (a) | Responsibilities for Major Events                            | - <b>Appendix A</b> |
| (b) | Inauguration of NCC RD camp                                  | - <b>Appendix B</b> |
| (c) | Visits of Dignitaries  | - <b>Appendix C</b> |
| (e) | Tea Reception at official residences of Service Chiefs/DGNCC | - <b>Appendix D</b> |
| (f) | Reception at Rashtrapati Bhawan                              | - <b>Appendix E</b> |

### **Camp Programme**

8. Secretary RD cell will prepare detailed camp programme by 15 Nov every year and send a copy to each Directorate and internal Directorates of DGNCC and HQ Delhi area. Additional copies, with changes, if any, incorporated will be issued on arrival of camp staff and on commencement of the camp.

9. The camp programme will reflect all events, training and administrative activities, visits, administration and sightseeing days and functions connected with the camp. Amendments if any will also be issued only by secretary RD cell and displayed in yellow coloured sheets on the notice boards.

### **Camp routine**

10. Daily camp routine will be as per **Appendix F**. All concerned will ensure that timings are strictly adhered to.

### **Daily coordinating conferences**

11. Conferences will be held daily to facilitate coordination, passage of orders and allotment of personnel and transport for events of the subsequent two days.

12. Administrative conference DDG (Lgs) DGNCC will hold this conference from 0800 hrs to 0830 hrs daily in camp offices area. Following will attend:-
- (a) DDG Lgs (in chair) and DD Lgs incharge MES works.
  - (b) Camp commandant (camp Adjutant will be left free to organize camp fall in).
  - (c) Quartermaster messing officer boys, Messing officer girls and interior economy officer.
  - (d) Officer Commanding boys and officer commanding girls wings.
  - (e) Any other officer required by the DDG (Lgs).
13. ADG (B)'s coordinating conference ADG (B) who is chairman of RD camp standing committee, will hold a coordinating conference in his office on 0900 hrs daily. Following will attend:-
- (a) All DDG, incl DDG Delhi
  - (b) Secretary RDC SC, Dir Coord and DD (pub).
  - (c) Camp Commandant.
  - (d) Camp Adjutant.
  - (e) OIC Boys 7 Girls Camp
  - (f) RMO.
  - (g) Nominated Contingent OIC
14. Other staff officers of Dte Gen NCC and camp staff may be asked to attend when required. Main aim is to coordinate programme and major events for the next day.
15. Camp Commandant's conference. Camp commandant will hold this conference from 1400 hrs to 1430 hrs daily in camp officers mess primarily to pass orders for the next day following will attend:-
- (a) All contingent commanders.
  - (b) Deputy camp commandant, Adjutant, Quartermaster, messing officer boys and messing officer girls.
  - (c) Officers commanding boys and girls wings.
16. The above conferences will start at scheduled time and officer taking the conference will ensure that conference is terminated by given time so that officers can attend to their duties and cadets are not kept waiting.
- Blood donation**
17. Secretary RD camp will reflect the blood donation day in the camp programme and arrange a visit by blood bank team to the camp. Blood donation will be organized by the camp commandant with the help of deputy camp commandant and the medical officer in the visitor tent area. Directotote contingents will be informed of number of cadets required to donate blood before the commencement of the camp. Contingent commanders will be responsible to provide the allotted number of cadets of appropriate age group out of those, who are not involved in republic day parade, guard of honuor, prime Minister's rally or any other such essential duties. Refreshments for the donors will be organized under the arngs of DDG P&F.

## **PART II: PREPARATION FOR THE CAMP AND CHARTER OF DUTIES REPUBLIC DAY CAMP STANDING COMMITTEE (RDCSC)**

18. Republic day camp is to be organized and run under the total supervision of directorate general NCC. For this purpose, a republic day camp standing committee (RDC SC) under the overall supervision of the Addl Director General (B) is formed by August every year. RDC SC will be responsible to the Director General to organize and run the Republic Day Camp in accordance with these standing instructions. Composition and functions of the RDC SC are attached as SOP at **Appendix G**. Charter of duties of various appointments id given at **Appendix H**.

19. The committee will generally meet on 02 of Aug, Sep, Oct, Nov, Dec, 20 Dec and 30 Dec and on any additional days ordered by the chairman to review the progress on sequence of preparatory actions listed in SOP and formulate policy on points/clarifications raised by the directorates.

### **Formation of RD cell at DGNCC**

20. Dir Trg (B) will be ex-officio secretary RDC SC and the main coordinator of RD camp. He will be assisted by a cell composed of following personnel. Who will be attached from directorates under the orders of MS, Lgs and P&F directorates of Dte Gen NCC:-

- (a) Asst Secy RDC.
- (b) Liason officer (LO) for prep & delivery of various welcome speeches & Commentary by cdts.
- (c) Two Typists from 01 Sep till 01 Feb.
- (d) one Light vehicle with driver from 30 Dec to 29 Jan.

### **Role & Charter of Duties**

21. Role of officers of DG NCC. Broadly the officers of the DG NCC deal with the general policy, laying down schedule of events, issue of camp programme, liaison with central Govt, service headquarters, and other agencies for provision of resources and monitor day to day conduct of programmes as per policy of DG NCC and provide necessary guidance to camp staff and Delhi Directorate. DGNCC officers also act as judges for various inter directorate of DGNCC.

22. Role of camp commandant and camp staff. Camp commandant and camp staff are responsible for compliance of policy, standing instructions, efficient conduct of camp programme, organize events/ functions under guidance of DGNCC staff, provide administrative assistance, ensure presence of competitors for various competitions and sound administration of the camp. this entails compliance of these standing instructions, obtaining guidance of secretary RD cell and ensuring proper conduct of events/functions/activities and exercising control over manpower and resources, for special to service activities like Air, Naval cultural programmes, guidance will be sought from respective JD.

23. Role of Delhi Directorate NCC Directorate Delhi is responsible for planning, organizing rehearsals and efficient conduct of Prime Minister's Rally. Policy decision and approval of programme of above function is, however, to be obtained through RD cell and concerned Dtes of DGNCC.

### **Preparatory Actions**

24. Changes in sequence of important events and actions that various directorates/branches of DG NCC are required to automatically initiate/take on various dates commencing w.e.f. 01 Aug, will be issued by RD cell buy 15 Jul. each internal Dte of DGNCC will work out their own sequence of events of their responsibilities during RDC and endorse a copy to secy RDC by 01 Aug each year.

**PART III – CAMP STAFF  
DETAILMENT OF CAMP STAFF**

25. Criteria. Camp commandant and other officers of the camp staff will be specially selected and detailed by name on the basis of following criteria:-

- (a) Suitability for the appointment and professional competence.
- (b) Good personal discipline, exemplary conduct and impressive/ smart bearing.
- (c) Approximately 1/3<sup>rd</sup> of each main group of camp staff will be out of previous RD camp staff so as to ensure continuity.

26. Responsibility for detailing. The responsibility and target date for detailments of personnel will be as under:-

- (a) Officers. MS Dte, DGNCC will obtain the recommendations of concerned directorates/branches and put up names of camp officers to ADG(B) for approval by 01 Aug.
- (b) PI staff. PI Staff will be detailed by MS Dte for RD camp from state directorates OTS/WOTS/DGNCC. Nominal roll of personnel detailed will be forwarded to MS Dte/DGNCC by 01 Oct.
- (c) Civilian staff. P&F Dte, DGNCC will issue detailment orders by 01 Jul.

Note: changes to appts may vary from year to year)

**Duties of Camp Staff**

27. Detailed duties of key personnel of camp staff are at **Appendix H**.

**Chain of Command**

28. All officers, PI staff and civilian employees on camp staff including those detailed for any special activity will be under the command of DDG (Lgs) through the camp commandant.

**Arrival schedule of Camp Staff**

29. The camp staff will arrive at RD camp ground as under:-

- (a) Layout group.
- (b) Advance party.
- (c) Main party.
- (d) Balance camp staff.

30. Camp commandant will ensure that camp is ready in all respects by 1000 hrs on 27 Dec.



## PART IV – DIRECTORATE RD CONTINGENTS

### General

31. Each NCC directorate sends a contingent to represent the directorate/state and Union Territories covered by it for the National Republic Day celebrations and to participate in RD Banner competitions and various functions/event of the NCC RD camp.

### Composition of directorate contingents

32. Each directorate contingent is composed of the following:

- |       |                      |   |   |
|-------|----------------------|---|---|
| (a)   | Contingent Commander | : | One Col/Lt Col/Major or equivalent of any service. Offr should not have been the Contingent commander earlier.  |
| (b)   | Contingent Officers  | : | One Male and one Lady ANO (any rank)  |
| (c)   | PI Staff             |   |   |
| (i)   | Adm JCO              | : | One (Sub/Nb Sub or Equivalent)  |
| (ii)  | Trg JCO              | : | One (Sub/Nb Sub or eqvt, Sub Maj or eqvt will NOT be detailed).   |
| (iii) | NCOs                 | : | Two NCOs or equivalent  |
| (d)   | GCI                  | : | One   |
| (e)   | Accounts Clerk       | : | One   |
| (f)   | Lascars              | : | Two (Separate instructions to be issued by P&F Dte, HQ DG NCC).   |
| (g)   | Dhobi                | : | One. One additional to directorates have cadet strength of over 100.  |
| (h)   | Cadets               | : | As per instrs from Office of Secy RDC. The Cadets will be organised in Platoons & sections under a cadet appointment. Cadets will wear actual Cadet appointments during the Camp. |

### Allotment of vacancies for cadets

33. Directorate wise allotment of vacancies are to be issued by RD cell every year by 15 Jul.

### Basis of allotment of vacancies for cadets

34. Allotment of cadet vacancies to directorates is to be made on following consideration:-

- |     |  |
|-----|--|
| (a) | Requirement of cadets of various wings for competitions, republic day parade, Prime minister's rally and other displays. |
| (b) | Enrolled cadet strength of directorates.   |

- (c) Additional vacancies may be to selected directorates above their share based on cadet strength to make their contingent of viable strength.

### **Procedure for Sub Allotment of Vacancies to Directorates**

35. NCC Directorates and state govts will be informed of final allotment of vacancies by 10 Aug so that states can release their share of necessary funds. In case of directorates covering more than one state/union Territories, the letters addressed to state govts will be routed through the directorate concerned, who will be required to fill in the exact number of part time NCC officers including GCI and cadets selected from each state/union territory to form part of the contingent in the letter and forward the same to state Govts/union Territory Administration concerned.

### **Policy on selection of the contingent**

36. The exact method of selection to be adopted for selection of the cadets depends on the duration for which the probable cadets are available, availability of funds and certain local conditions, which vary from state to state. It is therefore, not possible to lay down a uniform procedure to be followed by all directorates for selection of their contingents. The directorates will, however, follow the following guide lines for selection of their contingents:-

- (a) Selection at the unit and group level will be a continuous process and unit and group commanders will prepare a provisional list of cadets considered suitable for RD camp during various unit/group level camps, visits to sub – units for certificate examinations and special parades/competitions organized at unit/group level.
- (b) Directorates will convene a board of officers composed of minimum of three members to carry out an impartial selection of cadets in various categories and competitions.
- (c) If the cadets are of acceptable standard and fulfill the requirements of various competitions and special activities, efforts will be made to give a fair representation to the states/UTs and regions covered by the directorate, albeit merit alone should count for final selection of a cadet.

### **Eligibility conditions for cadets**

37. Cadets included by directorates in their RD contingents must fulfill the following condition:-
- (a) Cadets of 1<sup>st</sup> year of NCC training in their present division (senior or junior) will not attend.
  - (b) Repeaters are not permitted except the following categories:-
    - (i) R&V maximum of two RD camps.
    - (ii) Bands
  - (c) Cadets sponsored by the directorates for Youth Exchange Programmes must not be in the final year of the NCC or graduation course.
  - (d) Cadet must not be involved in any disciplinary case.
  - (e) Cadet must be medically fit. They will be protected against typhoid, tetanus and small pox. Cadets suffering from any communicable disease including skin disease will not attend.
  - (f) JD/JW - Attended a minimum of 75% of parades conducted during the 2<sup>nd</sup> year of NCC Trg and one annual training camp during the NCC service. JD cadets upto class X will only attend RD camp.

- (g) SD/SW – Should have attended a minimum of 75% parades conducted during each year of his/her NCC training and one annual training camp during the NCC service.

### **Special duty cadets**

38. Each directorate will forward names of cadets trained to perform duties as stated below on 05 Jan to Secy RDC (SC) in duplicate:-

- (a) One SD boy and one SW girl for reading vote of thanks in English and Hindi.
- (b) One SD boy and one SW girl for appointment as camp cadet captain of the day in rotation. These cadets are to be selected for their command and control, bearing and words of command.
- (c) Four JD boy cadets for traffic and RP duties and four JD cadets for Hygiene, sanitation and general duties.
- (d) Two SD cadets for detailment as stick orderlies to the DG.

### **Special training activities**

39. Contingent commander's will be required to provide cadets for special training activities and blood donation out of cadets, who are not selected for guard of Honour, RD parade, cultural shows, horse show and best cadet competitions.

### **Exemption of cadets from various contingent events of RD competitions**

40. Exemptions of cadets from various contingent events of RD banner competitions will be in accordance with the rules of such competitions issued by the DGNCC.

### **Intimation o breakdown o cadet strength**

41. Living accommodation for cadets are required to be sub allotted before the arrival of contingents. To avoid any changes in this allotment, directorate will furnish detailed composition of their contingent indicating number of cadets under each of the following categories to Lgs Directorate, HQ DGNCC on 26 Dec:

- (a) SD boys
- (b) JD boys
- (c) SW girls
- (d) JW Girls
- (e) Bands & R & V cadets (boys and girls separately).

### **Instructions for special categories of cadets**

42. Cadets Bands One boys and one girls band will be nominated for RD camp. Repeaters are permitted in this category. Although bands personnel will form part of the directorate contingent, they will be accommodated in separate accommodation (in boys/girls area) which will not be marked for line area competition. They will also not participate in Inter – directorate competitions. All bands will attain proficiency in playing National Anthem, and NCC song apart from two marching tunes and two slow march tunes each.

43. R&V cadets these cadets will also be accommodated separately in boys/girls area. Their accommodation will also not be marked for line area competition. Cadets of R & V may attend maximum of two RD camps. After the Horse show, Officers, cadets and staff not required for PM's rally (including reserves), will be sent back to their units in 20 Jan.

### **Documents concerning cadets/contingents**

44. By Advance Party – all directorates will send following documents duly signed, through their advance party (one NCO out of RD contingent staff) and hand over the documents as shown below:-

- (a) Bio-data and documents of the Best Cadets and Youth Exchange probable. These will be carried in sealed envelope addressed by name to the OIC competitions DDG (MS) and DDG (Trg) respectively and handed over on 20 Dec at DGNCC.
- (b) Final nominal roll of contingent officers, PI staff, civilian staff and cadets – three copies to secy RDC on 20 Dec.
- (c) Details of mode of travel, railway station, train date and time by which the directorate contingent would be arriving. One copy of this will be handed over at the camp commandant and one to Lgs Dte of DGNCC.

45. By contingent commanders The following documents will be brought personally by the contingent commanders and handed over to the authorities as against each-

- (a) Nominal roll 14 copies to be distributed as under:-
  - (i) Four copies to RD cell (Secy RDC).
  - (ii) Two copies to OIC competitions (DDG MS).
  - (iii) Three copies to the camp commandant including one for use of chief training officer.
  - (iv) One copy to the camp Adjt.
  - (v) Four copies to Dir Coord at DGNCC along with a certificate that antecedents of all ANOs/cadets have since been verified by the police.
- (b) Special nominal roll Nominal rolls for team/individual competitions will be given to OIC competitions before the competitions. Names of cadets for special duties will be indicated in these Rolls.
- (c) Identity cards All cadets attending the RD camp will be in possession of identity card, issued by the respective directorates. On arrival in the RD camp, these identity cards will be authenticated by the Camp Comdt/Adjt by affixing camp stamp.
- (d) Indemnity Bond All civilian staff and cadets will sign an indemnity bond and these will be submitted to camp commandant on 05 Jan.
- (e) Vouchers for weapons, arms and controlled stores on arrival will be handed over to the camp commandant.

### **Contingent stores, clothing and equipment**

46. The contingents will be required to bring the following for the RD camp:-

- (a) Arms. As required for all competitions.

(b) Contingent stores and equipment contingents will bring all stores and equipment required for use in various RD banner competitions and during the RD camp. Suggested list of the stores/equipment is at **Appendix J**.

(c) Clothing and necessities.

- (i) Uniforms including accoutrements.
- (ii) Mufti dress as approved by DGNCC.
- (iii) Personal clothing including additional winter garments.
- (iv) PT kit/dress for NCC run physical training and stores.

47. Cadets will be in possession of clothing and uniform items listed at **Appendix J**.

### **Arrival of contingents**

48. The contingents will arrive at the RD camp on 30 Dec as instructed by the DGNCC. Contingent commanders will ensure that instructions are strictly followed. Proper escort under PI staff will be detailed to ensure security of arms, ammunition and stores during the journey.

49. Sequence of action on arrival at RD camp is at **Appendix K**.

### **Duties of contingent commanders**

50. The contingent staff is to assist the camp commandant in ensuring that nominated cadets attend activities/functions punctually and highest standard of turnout, conduct and discipline is maintained.

51. Some of the duties of contingent commanders are at **Appendix K**

### **Cadet Appointments**

52. To enable the cadets to learn leadership by practice and play greater role in management of the camp, selected cadets will be nominated for following cadet appointments:-

(a) Camp Cadet Appointmentscamp comdt will nominate camp cadet captain, cadet captain (boys) and cadet captain (girls) out of names sponsored by the contingent commanders. Camp commandant will nominate cadets for security, traffic control, hygiene and sanitation and reception duties. Appointments will be changed every Wednesday. Camp comdt will also select daily, a smart and well turned out 'cadet stick orderly' out of cadets sponsored by contingents and appoint him as the DGs stick orderly.

(b) Contingent cadet Appointments contingent commanders will nominate cadets as contingents cadet captain (Boys), senior cadet boys, senior cadet (Girls), cadet sergeant Major, cadet Quartermaster, contingent writer, line sentries and cadets incharge of team/ party sent for any competition/event/camp function.

53. Above camp appointments will exercise control over cadets under their charge and ensure speedy "fall in", movement in proper squad, paying of compliments to officers and good conduct of their contingents.

### **Visit by DDG of NCC Dte**

54. Each DDG NCC Dte will be called on temporary duty for four days to visit RD camp. These dates will be coordinated by P&C Dte of DGNCC and will be inclusive of dates of arrival and

departure. DDG of champion Directorate will be present at Delhi to receive the RD Banner at the Prime Minister's rally on 27 Jan.

### **Flag Area**

55. Flag Area is one of the star attractions of the camp. It is therefore, the duty of camp commandant and contingent commanders to ensure that this area is properly maintained at all times.

56. Camp commandant will nominate an officer and a NCC cadet to exercise control over flag area. They will ensure that cadet's work on flag area only during permissible timings and equipment is kept uncovered for visitors from 0900 hrs to 1300 hrs and from 1700 hrs to 1900 hrs and for any other visits notified in the camp programme. Flags will be kept flying from reveille to retreat and area will be flood lit in the evenings. Sentry at main gate will control entry of vehicle and personnel.

57. On the days of VIP's visit to the camp, the camp commandant and contingent commanders will take a round of the flag area 45 minutes before the visit time and get it set right. Transparent covers may be used to protect flag area items during night and inclement weather. It will, however, be the duty of contingent commanders to get these removed in time.

58. Flag areas will be kept ready on all cultural show evenings and VIP/press party visits and will have cadets specially nominated and rehearsed for the flag area to explain the theme.

### **Notice Board**

59. Notice boards at the following places will be maintained for display of notices:-

- (a) RD cell - for DGNCC officers.
- (b) Camp officers mess - for camp officers and contingent commanders.
- (c) Camp Adj't's office - for boy cadets.
- (d) Girls area info room - for girls cadets.

60. A special score board will be put up near the first row of tents in the boys area facing auditorium No 1 for notifying scores of directorates in Inter-directorate RD banner competitions. All notice boards and the special score board will be maintained by the camp Adjutant.

### **Dispersal after the camp**

61. All contingents will disperse on 29/30 Jan under the respective contingent commanders. Delhi has a big tourist rush during the month of Jan. all directorates will, therefore, take advance action to obtain reservations for the return journey, taking into account their sightseeing plan after the camp. Bands cadets will also disperse alongwith Dte contingents.

62. Prior to departure from the camp, the contingent commanders and the camp staff will obtain clearance from all concerned.

## PART – V : DISCIPLINE AND SECURITY

### Discipline

63. General RD camp is a model camp visited by many dignitaries. The officers and cadets should ensure exemplary standard of turn out, behavior (both on parade and off parade) and ensure that various activities are conducted with a clock like precision. To achieve this, the camp commandant, the camp staff and the contingent commanders will ensure that special stress is laid on the following:-

- (a) Officers and cadets will be properly turned out at all times. Individuals will not wear any unauthorized items of clothing, ribbons and badges.
- (b) Movement of cadets within the camp will be in proper squads under a cadet appointment.
- (c) All functions/events will commence at the scheduled time. The tendency to make the cadets 'fall in' too much in advance will be curbed as it causes disruption of other activities.
- (d) All 'fall-ins' will be held in a military fashion and proper reporting procedure followed. Tendency to carry out lengthy 'fall-ins' without prior planning as regards the orders to be passed or sub allotment of cadets for various activities will be curbed.

64. Responsibility for ensuring good conduct

- (a) Camp commandant will be responsible for maintenance of discipline in respect of camp officers and cadets at all times including various functions outside the RD camp.
- (b) Contingent commanders will be responsible to ensure that cadets nominated for various functions and receptions, do not violate instructions passed by the RD cell or camp commandant. The senior most officer/cadet from each contingent present at a function will be responsible to check his cadets.

65. Discipline and conduct during functions with VIPs and special events. Camp staff and contingent commanders will ensure that the behavior of cadets at various functions/activities is exemplary. Following will be ensured:-

- (a) Camp staff and cadets are seated at least five minutes before the guests start arriving.
- (b) Cadets occupy only the allotted enclosure/seats. Boys and girls will be seated in separate enclosures.
- (c) ANOs (male and ladies), pl staff and GCIs are nominated for each function/event to ensure good conduct of the cadets. Cadets found making noise, shouting or whistling will be produced before the camp commandant.
- (d) All 'fall-ins' will be held in a military fashion and proper reporting procedure followed.

66. Out Passes No cadet will be permitted to leave the camp except for organized activity.

67. Sight seeing and shopping No sightseeing is permitted till the camp inauguration. Contingent commanders will organize sight seeing/shopping on the days reflected in the camp programme and ensure that all cadets get a chance in turn. Each sight seeing party will be accompanied by a



contingent officer/pl staff/GCI, who will be responsible to bring the cadets back to the camp by 1730 hrs.

68. Sight seeing outside Delhi will be permitted on 29 Jan. dress for sight seeing/shopping will be mufti only.

69. camp transport may be allotted for organized sight seeing within Delhi, when available. Before hiring buses for sight seeing contingent commanders will ascertain from camp commandant about the strength permitted to go out.

70. Function in the camp Auditorium In order to ensure smooth entry/exit of cadets, reception, ushering and seating of guests, maintenance of discipline during various camp functions, the seating in camp auditorium will be organized for all functions as per instructions contained in succeeding paras.

71. Entry/Exit. For entry and exit, the following entrances when facing the stage will only be used:-

- (a) Boy cadets & PI staff entrance from MI room side (left, when facing the stage).
- (b) Girls cadets and GCIs Entrance from camp offices side (right, when facing the stage).

72. Seating standard seating for all such assemblies in the camp auditorium will be (starting from front row to rear row of sofas/chairs/benches) as follows:-

- (a) Front row of sofas DGNCC staff and Lt Col and above of camp staff and DDG, director and Group commanders of Delhi Dte.
- (b) Second row for remainder officers of camp & Delhi Dte (if required 3 or 4 rows).
- (c) Subsequent rows:
  - (i) Girl cadets and GCIS (JW in front) - Right 1/3 of auditorium.
  - (ii) Boy cadets (JD in front) - Right 2/3 of auditorium.
- (d) Last three rows – PI staff.

73. Conduct during functions. Contingent commander's will nominate a contingent lady officer/GCI/PI staff each to sit in the last row of girls and one male ANO/PI staff to occupy seat on the side of boys enclosure to exercise control and check any talking/movement during the conduct of function.

74. Once everyone is seated, emergency exits (on both sides) will be opened by a PI staff to be detailed by the camp Adjutant.

75. All will keep the headgears on and remain seated but will be cautioned to word of command "Baithe Baithe Savdhan" at the time of reporting to camp commandant/ADG. They will remain seated, when the DG/Chief guest enters, unless specifically told to stand up. Caps/berets will be automatically removed once the talk/function starts and worn again at the end of the function.

76. Everyone will stand up when chief guest departs. Cadets will leave by respective exits after the officers have left the auditorium.



## Security

77. Responsibility Dy Camp Commandant is the Ex-officio camp security officer and fire fighting officer. He is responsible to the camp commandant for efficient implementation of camp security and fire fighting orders. These orders will be prominently displayed at various boards. After the DG's opening Address, the camp commandant will briefly explain these orders to all officers and cadets of the camp.

### 78. Security of stores

(a) Security of government stores in the RDC camp area shall be ensured through a system of "gate pass". Movement of stores out of the camp area will be permitted only through gate passes signed by the camp comdt (camp security officer). All gate passes will be serially numbered. Details of each pass issued alongwith details of stores for which issued and to whom issued will be entered in a register to be maintained by the dy camp comdt. A similar register will be maintained with the sentry at the exit gate of the camp. Details of all passes will be entered by the sentry in his register. The sentry will check stores being taken out and endorse as such on the gate pass. The gate pass will be retained by the gate sentry and returned next day to Dy camp comdt for his records.

(b) During RDC period the gate pass will be issued by the OIC DG NCC Camp.

### 79. Surprise Check Committee

(a) A surprise check committee directly responsible to the chairman RDC SC will function during the period of the RDC. The committee will be detailed by Secy RDC SC and will comprise of officers, 2 JCO's and 2 NCO's detailed out of DG NCC staff and RDC camp staff. The committee will carry out surprise checks as ordered.

(b) The names of the committee will be published by the RD cell and the committee will function on day to day basis. The committee will report to the Secy RDC at 0900 hrs daily for instructions.

(c) The committee will be responsible for carrying out surprise checks in all areas where purchases are made and will authenticate on the bills of all major transactions made during the day. The committee will report their findings daily to Secy RDC SC who will, in turn, keep the chairman RDC SC apprised.

80. Security of camp personnel. Most of the cadets who attend the RD camp are new to Delhi and large numbers of them are girls and junior division boys. It is, therefore, important that proper arrangements are made for their security both in the camp and also when they are out of camp for any training activity, functions or sight- seeing\shopping. The camp commandant assisted by camp security officer (deputy camp commandant), OSC boys & girls will be responsible to ensure security of all camp personnel. The security system will consist of camp guards and patrols, police guard and contingent line sentries.

81. Security of Arms and controlled stores. Weapons, ammunition and controlled stores will be kept under guard in the camp Kote. Officers or cadets will not be allowed to bring their personal weapons in the camp. Strict security measures for the safe custody of rifles and bayonets, their issue for parades/rehearsals and return to Kote, will be made. All rifles must be properly chained at night. One NCO will be detailed to be present in the kote both during the day and night.

82. Security of personal belongings. Contingent commanders will ensure that cadets do not keep any costly/valuable articles, jewellery of heavy cash with them. Lady Officers and girl cadets will not bring gold ornaments of costly jewellery to the camp.

83. Security of camp area. The camp security officer will arrange with the police authorities for perimeter patrolling of the camp during the night. He will also maintain close liason with HQ Delhi area, station HQ Delhi cantt, Army HQ camp and police authorities.

84. Security passes for civilian personnel. Security passes will be issued to all civilian personnel and labour employed in the camp. These will be checked by the security staff frequently. In case of casual labour, strict watch will be kept on their movement and entry/visit into the camp.

85. Visiting Hours. Relatives of the cadets will be allowed to visit the cadets between 1600 hrs to 1830 hrs daily except when there is a formal function in the camp. The visitors will report at the reception centre. OIC reception centre will arrange to call the cadet concerned through announcement on camp broadcasting system will also set up by camp Signal offr, in visitors tent. Cadets will be allowed to meet such visitors in the visitor's tent/barracks of the camp shopping complex. They will not be allowed to go outside the camp with them.

### **Fire Fighting**

86. Responsibility. Deputy Camp commandant will be Ex-officio fire fighting officer. He will be responsible to formulate and promulgate fire fighting orders. He will also liaise with Army HQ's camp, Delhi area and Air Force station and make arrangements for obtaining help from them in case of fire.

87. He will obtain approval of the Camp Commandant to the number and location of fire points and sub allot the responsibility for setting up and maintenance of these fire points. He will carry out fire fighting practice at least once a week after getting time approved from RD cell.

88. Contingent commanders should educate their cadets on the fire fighting arrangements. They will strictly enforce the following precautionary measures:-

- (a) No naked light will be permitted inside the tent/barrack.
- (b) All lights will be put off at the lights out time.
- (c) No one is permitted to smoke while attending a function/training. Activity, inside a tent or near a vehicle of inflammable material like the aircraft fuel, which should be well marked.

## PART VI : COMMUNICATIONS

### General

89. Efficient communications system is necessary for command and control and smooth conduct of various events/functions of the RD Camp. The following means of communication will be established:-

- (a) P&T telephones.
- (b) Field exchange and internal telephones.
- (c) Public call offices.
- (d) Camp broadcasting system.
- (e) Radio sets.
- (f) Public address system.
- (g) Special communication for PM's rally.

### P&T Telephones

90. The NCC Camp in Garrison parade ground, Delhi cantt has two permanent P & T Telephone (No 3293501 and 3292603). These telephones will be used in camp officer's mess and MT during the RD camp. Following additional telephones will be established by 01 Jan:-

- (a) DG and SO to DG - Plan 'A'
- (b) ADG 'A' and SPA to ADG 'A' -Plan 'A'
- (c) ADG 'B' and SPA to ADG 'B' - Plan 'A'
- (d) Secretary RDC SC
- (e) All DDG
- (f) JD YEP
- (g) Camp Comdt
- (h) Camp Exchahange - To be eatablished by 10 Dec
- (j) DD Pub
- (k) Dir Coord
- (m) Telephone with STD at Garrison Parade Ground PM's rally on 27 Jan.

91. P&F Dte of HQ DG NCC will be responsible to approach Headquarters Delhi area and P&T and get the additional telephones installed. Camp signal officer will ensure proper installation of the above telephones by 30 Dec.

92. Maintenance and repairs during the camp will be arranged by the camp signal officer.

### **Field Exchange and Telephones**

93. For internal communications, Camp signal officer will install an exchange.
94. Lgs Directorate will be responsible for provisioning of equipment and camp signal officer will be responsible for efficient functioning.

### **Pubic Call Office (PCOs)**

95. One PCO each with STD facility will be installed in Boys and Girls Areas under the arrangements of P&F Dte of HQ DGNCC.

### **Camp broadcasting system**

96. Camp signal officer will install an efficient broadcasting system for urgent announcements or for calling any member of camp staff/cadets to report<sup>6</sup> at various places at which they are required. The announcer's booth will be near the Adjutant office and visitor's tint near reception centre and loudspeakers will be so located that the announcements can be heard in all parts of the camp. Adjutant will be responsible to scrutinize the announcements before broadcasting so that contradictory or unauthorized announcements are not made.
97. Adjutant will also impose PA silence during any formal function in the camp, beating of retreat and Army day parade (also during the rehearsals of Army Commander, and GOC Delhi Area).
98. Lgs Ste will be responsible to consolidate requirement of radio sets and dets and arrange these from HQ Delhi Area/on loan from other agencies.
99. List of equipment required for communications, responsibility for arranging the same and source of procurement will be prepared in time.

### **Public Address system (PA system)**

100. Camp Signal Officer will make PA arrangements for the following:-
- (a) Camp inauguration and RM's visits.
  - (b) Cultural shows in main auditorium and camp officer mess.
  - (c) Lectures/functions in Camp Auditorium 1 and 2.
  - (d) Horse Show.
  - (e) NCC RUN.
  - (f) Reception at NCC house.
  - (g) PM's Rally.
  - (h) President's at home.
  - (j) PM's Lunch/Tea.
  - (k) Any other function requiring PA Eqpt.

101. To cater for breakdown of power supply, a stand by amplifier with alternative power supply will be arranged. Each amplifier will have two mikes. Number and type of loudspeakers will be so selected as to avoid harsh and jarring sound.

### **Special communications for PM's Rally**

102. Hotline JD Trg Air will arrange for a hot P&T line between the signal control cabin at the rally ground and Palam Air Field (Air traffic control) for direct communications for clearance of the air items of the rally.

103. PA Arrangements DG NCC (Lgs Dte) will be responsible for liaison with HQ Delhi Area Signal Coy and AHQ Sig Regt for provision of PA Eqpt for the PM's Rally.

## **PART VII : MISCELLANEOUS**

### **Information Rooms**

104. Information cum recreation rooms will be established in both the boys and girls areas under arrangements of P&F Dte. These will have the following:-

- (a) TV set
- (b) Newspapers and magazines.
- (c) Maps of India and capital city of Delhi.
- (d) Indoor games, carrom boards, playing cards, eight for boys and four for girls.
- (e) Information chart concerning career prospects in armed forces, these will be obtained from recruiting branch of Army, Navy, Air force and other services.
- (f) Incentives given to cadets.

105. OC boys and OC girls will be responsible to the camp commandant for upkeep of information rooms in their respective areas.

### **Publicity and public relations**

106. camp is the most important annual NCC event of National importance. It is therefore, essential that activities of the camp receive wide publicity on TV, Radio, newspapers, magazines and cadet journal.

107. Responsibility ADG (A) assisted by DDG (P&C) and DD (Pub) will be responsible for organising publicity and public relations concerning RD Camp.

108. Policy. To avoid disruption of camp activities due to the adhoc requirements of press/publicity during the camp, DD pub will formulate publicity policy for the camp by 15 Oct in consultation with secretary RDCSC and obtain DG's approval through ADG (A).

109. Publicity effort will consist of the following –

- (a) Preparation and printing of brief.
- (b) Suitable press release ten days before the commencement of the camp.
- (c) Visit of press and TV teams before the camp inauguration.
- (d) Press and TV coverage of camp inauguration, Horse show, visits of VIP's to the camp and cultural shows.

- (e) Special TV feature on the NCC RD Camp.
- (f) Est of motivation Hall.
- (g) Press and TV coverage of NCC contingents participating in RD Parade. DD Pub will also submit background material to DPR.
- (h) Press and live TV coverage of PM's rally. Draft commentary script will be submitted by Delhi Dte to RD cell for DG's approval.

### **Motivation Hall**

110. Motivation hall built in the RD camp premises consists of the following enclosures:-

- (a) Photo exhibition.
- (b) Army wing.
- (c) Navy wing.
- (d) Air wing.

111. DDG (P&C) will be responsible for overall coordination of functioning of the motivation hall. During the RDC two cadets for each enclosure will be detailed by the camp comdt to brief the visitors. Cadets for Army, Navy and Air Wing enclosures will be of the respective wings. These cadets will be selected from amongst the uncommitted cadets and will not be changed throughout the camp duration.

### **Preparation of briefs and hand outs on RD camp**

112. The following briefs and handouts will be prepared for the RD camp:-

- (a) Brief on NCC Special achievements of the current training year will be highlighted. 1000 copies of the 'NCC achievements and programme' will be kept available for distribution.
- (b) Brief on RD camp this will include historical perspective and special feature of the current RD camp. ADG (A), after obtaining DG's approval, will get adequate number of copies printed.
- (c) Briefs for VIP's invited for formal visit to RD camp. Secretary RDC will prepare these and send the same along with brief on NCC, Brief on RDC and minute to minute programme of visit/function to the VIP through the LO detailed by Dir MS to escort the VIP.
- (d) Briefs on cultural shows. OIC cultural will be responsible to prepare these under instructions of ADG (A).

113. **Background material for RD parade at Rajpath** DD pub will be responsible for updating the background material on NCC contingents and bands participating in RD parade and submit the same after approval of DG to DPR.

114. Commentators for all functions will be arranged by DDG (P&C).

### **Reception, ushering and seating: RDC functions**

115. A large number of VIP's visit the RD camp on official visits and as chief guest at various functions organised during the RD camp. Detailed SOP on reception, ushering and seating for the visits/functions is at **Appendix L** for compliance.

### RESPONSIBILITIES FOR ORGANISING MAJOR FUNCTIONS

1. Camp inauguration - ADG (B)
2. Competitions - DDG (MS)
3. Press visit - ADG (A), DDG (P&C) & DD Pub
4. Visits : RM/RRM and service chiefs. - ADG (B)
5. Visit CAC members - ADG (A), DDG (P&C) Dir (Coord)
6. Cultural shows - ADG (A) DDG (P&C) OIC cultural
7. RD parade and guard of Honour - DDG (Trg) – CTO
8. Horse show & band display - DDG (Trg) – OIC R&V Lgs aspects by DDG (Lgs) and Camp Commandant.
9. PM's Rally
  - (a) Coord - ADG (B) and Secretary RDC
  - (b) Organisation & conduct - DDG Delhi
  - (c) Tfc Cont, seating, ushering & security– DDG (P&C), Dir Coord
10. Tea at Rashtrapati Bhavan - Secretary RDC Camp Comdt.
11. Lunch/Tea at PM's Residence - Secretary RDC CAMP COMDT.
12. Reception at Army House - Secretary RDC SC
13. Reception at Navy House - Secretary RDC SC
14. Reception at Air House - Secretary RDC SC
15. Reception at NCC House - Secretary RDC SC and SO
16. Blood donation - Camp Commandant, Camp MO
17. Barakhana - Camp Commandant.

## SOP – CAMP INAUGURATION

### General

1. This function is organized to make the formal inauguration of the RD camp. The function is, generally, organized five to six days after the commencement of the camp, so that the camp is sufficiently ready and in a presentable condition. The Vice President of India is, generally, the chief Guest. A request to the vice president is initiated by DG NCC (coord) under the signatures of DG by 10 Nov.

### Venue Date and Time

2. The function is organized in the Guard of Honour ground at 1100 hrs.

### Dress

3. (a) Service officers, PI staff and cadets - Winter Ceremonial, Full Medals (Dress No 1)
- (b) Civilians - National Dress/Lounge suit.

### Participation

4. The following will participate in this function:-
- (a) Guard of Honour – 120 cadets, One Military Band & Two NCC Bands.
- (b) Vote of thanks and welcome address – One cadet each for Hindi and English.
- (c) Personnel on duty in the motivation Hall & Flag Area
- (d) Cadets for cultural show in auditorium .

### Overall Responsibility

5. ADG (B) will be responsible for organisation and smooth conduct of the function.

### Division of Responsibilities

6. (a) Preparation of Ground - Camp Commandant.
- (b) Preparation of Flag Area - Contingent Commander.
- (c) Guard of Honour, Band and Buglers. - DDG (Trg)& CTO.
- (d) Cultural show Auditorium . - OIC cultural under the supervision of ADG (A) DDG (P&C).
- (e) Motivation hall - Respective OIC.
- (f) Tea & Refreshment. - ADG (A) & DDG (P&F).



## SOP : VISITS OF DIGNITARIES TO CAMP

### General

1. It is customary to invite Ministers of Ministry of Defence, service Chiefs and Defence secretary to visit the camp. Dates and timings of visits are reflected in tentative schedule of Major events which is prepared by Secretary RDCSC. Based on this, DG NCC (coord) sends out requests to VIP's for appointment under the signatures of DG with a copy to RD cell.

### Aim

2. Aims of these visits are to:-
- (a) Afford opportunity to VIP's to view the camp and meet maximum camp staff and cadets.
  - (b) Project image of NCC with a view to obtain their patronage and also raise the status of RD camp.
  - (c) Afford an opportunity to campers to meet VIP's.

### Responsibilities

3. ADG (B) assisted by secretary, RDCSC will coordinate all preparations for the visits.
4. **Secretary RDCSC**
  - (a) Prepare schedule of visits.
  - (b) Brief conducting officer/escort and through him send the Brief on NCC, Brief on RD camp and programme of visit, to the VIP.
  - (c) Issue instructions regarding attendance in functions.
  - (d) Organise Presentation of mementoes to the VIP's as approved by DG.
  - (e) Approach service HQ's for detailing Band and Buglers.
5. **DDG (Training)** Assisted by CTO organize fanfare by service Buglers, and Guard of Honour on arrival of VIP. Flag will remain unfurled.
6. **Dir Coord** Organise seating arngs, ushering and traffic control.
7. **Camp Commandant**
  - (a) Get the camp, including the Flag Area and cadets lines, ready for the visit.
  - (b) Ensure that camp staff and cadets are at the assigned paces at least 15 minutes before the visit time.
  - (c) Ensure proper conduct of cadets during Mess function. VIP will not be requested for autograph or individual/directorate wise photograph. Cadets will remain dispersed and not crowd around the VIP.
  - (d) Organise tea for the drivers and CMP escorts of the VIP.

## Sequence of Actions

8. Recommended Sequence of events is as under.

(a) **Investiture Ceremony of Hon'ble RM.**

<b>SNo.</b>	<b>Time</b>	<b>Events</b>
1.	1100Hrs	The Hon'ble Raksha Mantri arrives and is received by DG NCC. Fanfare is played by buglers
2.	1100-1102Hrs	Introduction to ADGs and DDGs. Bouquet presented to RM
3.	1102-1107Hrs	Chief Guest takes salute from Saluting Dais, inspects Guard of Honour and returns to Saluting Dais.
4.	1107-1112Hrs	Presentation of RM's Padak and Commendation Cards.
5.	1112-1125Hrs	Witness Band Display.
6.	1125-1140Hrs	Visit Flag Area and Mov to Auditorium.
7.	1140-1145Hrs	Address by DG.
8.	1145-1200Hrs	Witness Cultural Programme.
9.	1200-1205Hrs	Address by Hon'ble Raksha Mantri.
10.	1205-1215Hrs	Presentation of Memento to Hon'ble Raksha Mantri by DG NCC followed by NCC Song.
11.	1215-1230Hrs	Tea and Photograph with Cadets in Officers Mess complex
12.	1230Hrs	Hon'ble Raksha Mantri Departs.

(b) **Visit by Other Dignitaries incl Service Chiefs.**

<b>S No</b>	<b>Time</b>	<b>Event</b>
1.	1100Hrs	Arr of VIP and is received by DG NCC. Fanfare played by buglers
2.	1100-1102Hrs	Intro to ADGs and DDGs. Bouquet is presented to Civilian dignitaries and First Lady only
3.	1102-1107Hrs	Inspect Guard of Honour.
4.	1107-1122Hrs	Witness Band Display.
5.	1122-1135Hrs	Visit Flag Area
6.	1135 -1145Hrs	Visit Motivation Hall and Mov to Auditorium.
7.	1145-1150Hrs	Address by DG.
8.	1150-1210Hrs	Witness Cultural Pgme.
9.	1210-1215Hrs	Address by the CAS.
10.	1215-1220Hrs	Presentation of Memento to VIP by DG NCC followed by NCC Song.
11.	1220-1230Hrs	Tea and Photograph with Cadets in Officers Mess complex
12.	1230Hrs	Dep of VIP.

## Dress

9. (a) Service officers, PI staff and cadets - Winter Ceremonial, Full Medals (Dress No 1)  
 (b) Civilians - National Dress/Lounge suit.

## SOP : TEA RECEPTION AT OFFICIAL RESIDENCE OF SERVICE CHIEFS& DG NCC

### General

1. It is customary for the Chief's of the Army, Naval and Air staff and the Director General NCC to invite approximately 15 officers and 250 NCC cadets to their official residence for a tea party. The function is generally held at 1530 hrs and its duration is approximately one hour.

### Responsibility

2. Dir Coord Initiation of formal request to service Chief's giving suggested date and time in consultation with secretary RDCSC.

3. Secretary RDCSC Inclusion in camp programmes and issue of criteria for attendance of function.

4. Camp Commandant Detailment of officers and cadets strictly as per criteria issued by RD Cell. Where cadet is not available another cadet of same wing from same contingent may be detailed. He will also organise briefing, checking o dress and ensure officers and cadets concerned reach the venue five minutes before the time. He will also ensure orderly behavior of the cadets throughout the function.

5. **Nominated LO** Coordinate and attend reception of respective service Chiefs, organise reading of vote of Thanks by a selected and rehearsed cadet.

### 6. Dress

(a) Officers Winter Ceremonial with medal ribbons unless specified otherwise.

(b) Cadets. Terricot uniform with Jerssy pullover unless otherwise specified.

### 7. Sequence of Actions

(a) "Fall In" of nominated camp officers and cadets in embussing area and final briefing by the camp Commandant.

(b) Embussing and arrival at the venue 15 minutes before the time. DGNCC officers and visiting DDsG who are to attend the function will reach the venue directly.

(c) Debussing, quick forming up and move to the venue in an organised manner. Cadets will pay compliments and wish service Chiefs and other hosts and then spread out in small groups.

(d) Tea and group photographs. No request will be made for individual photographs or autographs.

(e) Reading of vote of Thanks by a cadet as rehearsed earlier, followed by NCC song.

(f) Bid farewell and thank the host.

(g) Departure for debussing area, embussing and return to camp in a convoy.

(h) Camp signal Officer will install PA system in the DG's residence for reading vote of Thanks by a cadet on the day of reception at the residence of the DG.

**SOP : RECEPTION AT RASTRAPATI BHAWAN****Introduction**

1. It is customary for the Rashtrapati to invite all officers and cadets of NCC RD camp for tea at the central lawns of Rashtrapati Bhavan on 27/28 Jan.

2. Secretary RDC initiates request for above function through a DO letter from DG to Military secretary to the Rashtrapati during November.

**Responsibilities**

3. The responsibilities for the above function will be given in succeeding paras.

4. **Secretary RDC SC**

(a) Sending proposal for the function and subsequent liaison with Rashtrapati Bhavan staff.

(b) Arranging coord meeting between NCC staff and Rashtrapati Bhawan staff.

(c) Submitting particulars of official photographer to Rashtrapati Bhawan staff.

(d) Informing DG NCC officers, visiting DDsG, Delhi Directorate and camp offrs, about the date and time for the function.

5. **Camp Commandant**

(a) Detailing and briefing of officers, PI staff and cadets.

(b) Organise route recce and ascertain time required for move of convoy and ensure timely arrival of cadets.

(c) Organising move of camp personnel to Rashtrapati Bhawan and maintenance of discipline after the function. Particularly, preventing cadets from straying in other areas, plucking flowers/fruits and organizing smooth exit and embussing.

**Attendance**

6. The following attend this function:-

(a) All officers of DG NCC and their Spouses.

(b) Dy DG, Dir and GP Cdrs of NCC Dte Delhi and their spouses.

(c) Visiting DDsG and their spouses.

(d) All Officers, PI staff and cadets of RD camp and contingents except those on essential camp security duties.

**Dress**

7. The following dress will be worn:-

(a) Officers and PI staff winter ceremonial with full medals.

- (b) Cadets Winter ceremonial (Terricot uniform with/Jerssy pullover). Blazers will not be worn/carried.
- (c) Caps will be worn throughout the function.

### Preparatory Actions

8. Coord Conference Secretary RDC will meet Dy MS to the President and finalise details of the function. This will be followed by a Coord conference between NCC staff and Rashtrapati Bhawan staff in the central lawns on the fixed day. Following will attend from NCC side:-

- (a) DGNCC Secretary RDC, and OIC cultural.
- (b) Camp Staff Camp Commandant, Adjutant, OC boys, OC girls, MTO, QM, Messing Officer, photography officer, signal officer, camp Sub Maj and one JCO each from Messing, signals, MT and QM staff.

9. The following will be finalised at above conference:-

- (a) Minute to Minute programme and sequence of events.
- (b) Entrances to be used, security clearance and arrangements for speedy passage of cadets.
- (c) Parking of vehicles and traffic control.
- (d) Establishment of additional urinals.
- (e) Seating plan for officers in the front row of chairs. 15 chairs will be left for Rashtrapati's personal guests and balance for the visiting DDsG DGNCC Staff, Camp Commandant, under study Camp Commandant, Deputy Camp Commandant. Others will occupy second and third rows.
- (f) PA arrangements and place for cultural items by the cadets.
- (g) Strength for Refreshment.

10. **Briefing of Officers and Cadets** Camp Commandant will ensure that Camp Staff and Cadets are briefed on the function on 25 Jan. Following will be stressed-

- (a) Dress will be winter ceremonial- Officers will wear full medals.
- (b) No cameras, Hand bag or autograph books will be carried. These will be checked, confiscated and left behind in the Camp before embussing.
- (c) Front row of chairs will not be occupied by Camp personnel except Camp Commandant and under study camp commandant.
- (d) When the President walks past cadets will not break the lint/formation. Cadets will stand at Savdhan. There will be no saluting. It will be explained that President will be seated in full view of the cadets.
- (e) Officers and cadets will not go to any other part of the Rashtrapati Bhawan or Mughal Gardens. They will use the path ways and NOT walk through flower beds. There

will be no loitering, plucking of flowers/fruits after the refreshment. Disciplinary action will be taken against defaulters.

(f) When National Anthem is played, no one will salute but will properly stand up by keeping dressing from the front. There will be no talking or un-necessary movement.

(g) Contingents Cdrs are requested to ensure that Offrs of their contingent are adequately briefed that once cadet's form up for tea, girls cadets of their Dtes are allowed to take the food packets first.

(h) Distribution of food packets for the cadets will be organised, Directorate wise (separately for boys and girls), by the messing offices. They will be assisted by one ANO (Male) and two cadets (SD and SW) forming part to advance party.

(j) Camp Commandant will detail officers, PI staff and GCIs by name who will remain with the cadets including for tea/refreshment and be responsible to ensure that cadets move from south lawn direct to vehicle parking area and forming up into vehicle loads without and talking camp commandant and contingent commanders will also take charge of their cadets immediately after president's departure and ensure that their cadets mount their vehicles.

(k) Empty food packets will be thrown only in the dust bins. No litter will be thrown on the lawns. OIC messing will have the area cleaned before departure.

(l) After refreshment, cadets will move contingent wise in two files to the exit points. Girl cadets to leave first. Convoy will move back to the camp. No cadet/officer will go out anywhere else.

(m) Adjutant assisted by PI staff, nominated by camp commandant to attend the function, will ensure that immediately after consuming the food packets, cadets move directly to the exit gate and fall in at the embussing area. No loitering or straying into other parts of Rashtrapati Bhawan will be permitted.

(n) No cadet to seek autograph or individual/group photo with the President. Photo Officers will take photos as briefed.

(o) Camp Comdt will detail offrs from each contingent to identify cadets. These offrs will assist security staff of the Rashtrapati Bhawan and also carry nominal roll of officers and cadets for identification.

11. The function will be held in following five parts:-

(a) Debussing, entry and forming up of camp personnel and cadets in a hollow square.

(b) Playing of National Anthem followed by introduction to the ADsG, foreign cadets and best Cds.

(c) Cultural show by cadets.

(d) Tea and Refreshment.

(e) Exit, embussing and return to camp.

12. All officers and cadets will have to pass through metal detectors. They will carry their identity cards with them. Officers except those accompanying the cadets will arrive at the reception

via South Sunken Road. Asst Adjt to lead the vehs of camp Offrs to reception centre and will guide the offrs and assist in identification of officers to the security staff.

13. Minute to Minute programme is enclosed at Annexure.

### Post Function Actions

14. In case the Rashtrapati announces any cash award for the cultural items, the cadets who actually present the items will be paid their share through their contingent commanders on 28 Jan, before the dispersal, by the camp commandant and amount recouped by advance from DG Regtl Fund which in turn will be recouped when the amount is received from the Rashtrapati Bhawan.

15. Secretary, RDC will put up draft letter of Thanks from DG to the Rashtrapati for giving privilege to the NCC officers and cadets.

### Appendix F

#### RD CAMP : CAMP ROUTINE

Ser No	Time(hrs)	Event
1.	0545	Reveille and morning Tea.
2.	0630-0700	Preparation for days activities/PT/Riding
3.	0700-0830	Breakfast.
4.	0830	Sick Report.
5.	0830	Camp fall in.
6.	0900-1230	Forenoon Training/activities session.
7.	1230-1400	Lunch and rest.
8.	1400	Camp fall in.
9.	1415-1630	Afternoon training/activities session.
10.	1630	Special sick report.
11.	1630-1700	Evening Tea.
12.	1700-1800	Bathing.
13.	1800-2000	Evening Activities session
14.	2000-2130	Dinner.
15.	2200	Lights out.

#### Miscellaneous Timings

16.	0930-2200	Shopping complex and CSD canteen timings.
17.	1630-1830	Visiting Hours.
18.	1400-1800	Banking hours.
19.	1000-1700	Post office timings.

**Notes:-**

1. Meals will not be served beyond timings laid down above.
2. Cadets will not visit shopping complex between 0830 to 1300 hrs.
3. PI stall dinner will be from 1830 to 2130 hrs.

**Appendix G****NCC RD CAMP STANDING COMMITTEE (COMPOSITION AND DUTIES)****General**

1. For the organisation of the NCC RD camp and to coordinate the activities, therein, a separate standing committee is formed every year w. e. f. Aug. the committee is under the overall direction of Addl Dir Gen NCC (B) and is responsible to the director general to organise and the camp in accordance with these instructions and also project an example of a model NCC camp in all respects. The composition of the RD camp standing committee (RDC SC) will be as under:-

Chairman	-	Addl Director General (B).
Members	-	Dy DG (Training), Dy DG (Lgs), Dy DG (MS), Dy DG (P&C), Dy DG (P&F), Dy DG NCC Dte Delhi, Dir Coord, Dir (Fin), JD (Pub) & Camp Comdt
Secretary	-	Dir Trg (B)

2. Camp Commandant will be called on temporary duty for conference in mid Oct. He and Chief Training Officer may be called to attend conferences of RD camp standing committee after their arrival at the camp if required.

3. P&F Dte will detail two clks for RD Cell wef 01 sep till 01 Feb for RD Cell. Director Training (B) will be ex-officio Secy RD Camp Standing Committee (RDC SC). He will be assisted by a cell composed Asstt Secy & Liaison officer (LO). Any changes/ modifications to scheduled programme will be issued only by RD cell. RD cell will shift to the camp during last week of Dec and start functioning from there.

4. **Functions of the RD Camp Standing Committee.** RDC SC will be responsible to plan, coordinate and monitor all activities/functions of the RD camp. It will also be responsible to DG NCC for smooth and efficient functioning of the RD camp.

**1 Competitions**

Conduct of all RD Banner competitions including best cadet competitions under supervision of DDG (MS)	By BOO
Conduct of cultural competitions & Programmes	DDG (P&C)
Compilation of RD Banner results & Obtaining approvals of the DG	DDG (MS)
Detailing of boards of screening of youth exchange probable.	DDG (MS)

**2 Refreshment and Establishment subjects**

Functioning of shopping complex and DG NCC wet canteen	DDG (P&F)
<ul style="list-style-type: none"> <li>• Refreshment arrangements during visits of VIPs/Press/CAC members and horse show.</li> </ul>	



- Preparation of menu. Layout of tables and crockery decoration, fixing of table cloth and horticulture.
- Provision of Telephones, TV, VCRs, PCOs and videoramma.
- Provision of flower pots/foilage plants from horticulture department and their display.
- Provision of Post office and bank extension counter.
  
- Provision of stationary from CAO for camp and arrangement of admit cards for RD parade and beating the retreat etc including for foreign cadets.

**3 Detailing of civilian personnel and arrangements for typewriters and budgetary provision for camp**

	Detailing of civilian staff for RD camp, RD cell and CTO's office	DDG (P&F)
	Typewriters for RD camp invitation cell and CTO's office	DDG (P&F)
	Budgetary provision including receipt of bank draft from NCC Dtes, opening of Camp accounts and Audit of RD camp accounts.	DDG (P&F)
<b>4</b>	<b>Ceremonial</b>	
	Issue of invitation, Inviting VIPs/Chief Guests	Dir Coord
	Security and Traffic control	Dir Coord
	Ushering	Dir Coord
	Identity/security cards.	Dir Coord
	Seating plan for all functions.	Dir Coord
	Programme of visiting state Dy Dirs Gen.	DDG MS
	Investiture ceremony for award of Raksha Mantri's Padak and commendation card	DDG MS
<b>5</b>	<b>Publicity and Motivation Hall</b>	
	Publicity, public relations, visit of CAC members and Press, submission of background material for RD camp, PM's Rally and RD parade.	DDG (P&F), DDG (P&F), JD (Pub)
	Motivation Hall	JD (Pub)
	Establishment of photo cell.	DDG (P&F).
<b>6</b>	<b>RD Cell</b>	
	Overall planning and coord of RD camp.	
	Issue and revision of policy decision and standing instructions.	
	Coord with Min o fDef, Army HQ, HQ Delhi Area and other agencies, (JDS (Trg) Navy and Air will help in coord with Naval and Air HQs).	
	Preparation of camp programme, schedule of events and selection of Chief Guests for various occasions.	
	Sub allotting camp vacancies and requesting State Govt for release of funds to Dtes.	
	Coordination, monitoring and execution of camp schedule/programme.	
	Staff work connected with President's 'At Home', PM's Lunch/Tea and Tea parties at residence of service chiefs.	
	Conduct of RD coord conference and daily conference of Addl DG (B) during RDC.	
	Arrange Bands and Buglers from respective service HQs to further function under DDG (Trg)/CTO.	
<b>7</b>	<b>Training (under supervision of DDG (Trg))</b>	
	Training and rehearsal of RD contingents Guard of Honour, Band and R&V det	CTO/OIC/R&V
	Conduct of programme of foreign cadets.	JD YEP

Horse show and Band display	JD (R & V) OIC R&V.
Prize distribution	OIC Prizes (Dir Trg A).
Forecasting requirement of Prizes/Trophies and informing Lgs Dte for procurement action	OIC Prizes (Dir Trg A).
Coordination and employment of Band and Buglers including PM's Rally.	CTO
Screening of Youth Exchange Probable's	DDG MS

## 8 Administration

Detailed layout of camp. Setting up of Camp including preparation of Guard of Honour area and Visiting state DDG's accommodation. Dy DG (Lgs) & camp Staff. Complete camp Adm, including Messing and Tpt. MES works and allied amenities. Adm of foreign cadets including Accommodation and bedding. Procurement and polishing of Prizes/Trophies, souvenirs, including mementoes for foreign cadets, PM's Rally, RD Banner competitions held at RD camp and at centrally organised camps. Monitoring the expenditure and ensuring compliance of procedure regarding messing, contract for furniture and other item under Lgs Dte. Decoration of camp and PM's Rally ground. Setting up and decoration of saluting base and dais for functions including PM's Rally.	Dy DG (Lgs) & Camp Staff
--	-----------------------------

Functioning of CSD and non CSD canteens in Camp including stocking of badges and accoutrements	DDG (MS)
--	----------

Provision of medical facilities MO, ambulance MI Room and medicines	DDG (Lgs)
---	-----------

## 9 PM's Rally

ADG Delhi

## 10 RD Camp

Smooth running and Adm arrangements of camp including Adm arrangement for competitions.	Camp Comdt
Efficient execution/conduct of camp programme and instructions.	
Provide staff, stores, resources and tpt for all functions connected with RD camp and PM's Rally. Camp Comdt and his staff.	
Ensure good conduct and control over cadets in camp and all connected functions including those outside the Camp.	
Discipline, welfare and security of camp officers and staff.	
Organisation of all functions in camp under the guidance of DG NCC staff.	
Reception and dispersal of contingents. Publication of camp Routine orders.	
Camp Commandant	





## CHARTER OF DUTIES OF APPOINTMENTS DURING NCC RDC

### TRG DIRECTORATE

#### Dir Trg (B)

1. Issue tentative allotment of cadet vacancies to all Directorates by May every year.
2. Issue sequence of preparatory actions (check list) by Aug.
3. Obtain approval of DG to suggested list of Major Events.
4. Convene pre-RD conferences. MS Dte to call Camp Commandant for conference in mid October.
5. Initiate note for President's At home on 28 Jan by first week of November.
6. Issue final schedule of Major Events by 21 December.
7. Initiate note to AG's Branch for service band and service buglers.
8. Issue detailed camp programme.
9. Initiate action for DO letter from DDG Trg to BGS IMA for making available of drill instructors from IMA. Also DO letter from DDG (Trg) to Commandant OTS and WOTS for good drill instructors.
10. Obtain DG's approval of detailed programme for camp inauguration, visit of VIPs, Horse show and PM's Rally.
11. Initiate action for obtaining officers of 61 Cav, R&V, PBG as judges for R&V competitions.
12. Approach HQ Delhi Area for allotting suitable enclosure for NCC cadets to witness beating of retreat rehearsal at Garrison Parade Ground on 13 Jan, Army Day Parade on 15 Jan and view Defence Eqpt/weapons.
13. Finalise order of march of NCC contingents for RD Parade in consultation with AAG Delhi Area and issue to all concerned.
14. Get RD Camp merit certificates printed for issue to entitled cadets.
15. Prepare brief on RD Camp.
16. Prepare briefs for various Chief Guests and their suggested speeches.
17. Prepare draft Vote of Thanks and Welcome Address.
18. Prepare points for DG's opening address.
19. Inform Directorates/state Govts for release of funds for their cadets attending RD Camp.
20. Finalise minute to minute programme of PM's Rally.
21. Obtain rehearsal schedule for RD Parade from Delhi Area and issue to CTO.
22. Send names to Dir (coord) for security clearance of officers/cadets including the following, coming close to the Prime Minister during PM's Rally:-
  - (a) Prize winners.
  - (b) Guard of Honour.
  - (c) Cadets carrying prizes.

- (d) Cadets on duty in Flag Area and motivation hall on 27 Jan.
- 23. Ask for feedback from all officers attending RD Camp.
- 24. Issue criteria for cadets attending tea/reception with various VIPs.
- 25. Arrange coordinating conferences.
- 26. Preparation of RD camp merits certificates.
- 27. Intimate results of RD competitions to all Directorates.
- 28. Send particulars of all India Best Cadets (SD Army, SW Girls) to the COAS for information and request for release of scholarships.
- 29. Arrange issue of letter of Thanks to various dignitaries for their help in conducting the RDC camp.
- 30. Updating the competition Rules.

### **Dir (Trg A)**

- 31. Forecasting requirement of Trophies and prizes for all competitions and informing Lgs Dte for procurement action.
- 32. Organise ceremonies for presentation of trophies and prizes along with merit certificate at all functions except at NCC Air show and Naval display of water sports (Regatta) which will be the responsibility of the conducting Dte.
- 33. Organise awards presentation ceremony at PM's Rally and obtain security clearance for all those involved in the ceremony through Dir Coord.
- 34. Prepare written question papers in service subjects for best cadet competition Army and Girls wings under the direction of Dy DG MS.

### **JD Trg (Navy)**

- 35. Issue rules/policy decision for Naval wing competitions.
- 36. Conduct Naval wing competitions.
- 37. Submit results of Naval wing competitions to secretary RDC SC for informing Dtes.
- 38. Ensure adequate and timely arrangements by conducting Dtes for conduct of Naval wing competitions at Nau Sainik camp and activities during PM's Rally.
- 39. Submit to Trg (A) by 31 Jul the list of prizes required for Naval wing activities.
- 40. Submit to MS Dte the names of Naval wing officers and PI staff required for the RD camp.
- 41. Initiate note to Naval HQ for six buglers for camp inauguration, CNS visit, and PM's Rally.
- 42. Coord tea reception at CNS residence in conjunction with secretary RDC. Also select and train a Naval cadet to read Vote of Thanks.
- 43. After, the RD camp, particulars of all India Best cadet (Naval Wing) be sent to service HQ for obtaining scholarship.
- 44. After the RD Camp submit Draft Dos to agencies that helped in organising Naval wing activities to RD cell and on approval issue the same.
- 45. Prepare written question papers on service subjects for Best cadet competition under the directions of Dy DG MS.

**JD Trg Air**

46. Issue rules/policy decision for Air wing competitions.
47. Conduct of Air wing competitions.
48. Submit results of Air wing competitions to secretary, RDC SC for informing Dtes.
49. Ensure adequate and timely arrangements by conducting Dte for conduct of Air wing competitions at Vayu Sainik camp and display of Air wing activities at the PM's Rally.
50. Lay down policy and provide guidance and assistance for sorting out any problems regarding Air Wing activities at the RD camp and PM's Rally.
51. Submit to Trg (A) by 31 Jul the list of prizes required for Air Wing activities.
52. Submit to MS the names of Air wing officers and PI staff required for the RD camp.
53. Initiate note to Air HQ for six buglers for camp inauguration, CAS visit and PM's Rally.
54. Coord tea reception at Air house in conjunction with secy RDC, also select and train an Air cadet to read vote of Thanks.
55. After the RD camp particulars of all India best cadets (Air wing) are sent to service HQ for obtaining scholarship.
56. After the RD Camp, submit draft Dos to agencies that helped in organizing Air activities to RD cell and on approval issue the same.
57. Obtain approval from the DG regarding cadets doing gliding powered flying at PM's Rally and inform NCC Dte Delhi/camp.
58. Prepare written question papers on service subjects for best cadet competition under the directions of Dy DG (MS).

**Chief Trg Offr (CTO)**

59. Training and preparation of NCC contingent for the RD Parade, Guard of Honour and PM's Rally march past.
60. Supervise training activities for uncommitted cadets.

**JD Trg (R &V)/ OIC R&V**

61. Organise NCC horse show and band display and conduct of equestrian competitions including detailing of judges.

**LGS DIRECTORATE**

62. Arrange for PA Eqpt from Delhi area Signal Company.
  - (a) Obtain Govt sanction for transport, amenity transport, free accommodation, electricity and water for the use of NCC cadets in the RD camp.
63. Liaise with HQ Delhi area and settle all matters pertaining to NCC RD camp site/area.
64. Establishment of camp and preparation of Guard of Honour Area.
65. Camp Adm including messing of all personnel including visiting state DDsG NCC, PI staff and civilian.



66. Make provision for transport, drivers and FOL.
67. Procurement of prizes including sandal wood batons/souvenirs/trophies as per requirements intimated by Trg Dte, including polishing/repair of trophies.
68. Administration of foreign cadets including accommodation, bedding, messing, transport and mementoes in conjunction with Trg Dte.
69. Arrange for furniture required in the RD camp including for foreign cadets, visiting DDG NCC, PM's Rally and other camp events/functions.
70. Arrange for eight water trailers on loan from the Army.
71. Arrange for loan issue of the following:-
  - (a) Tentage
  - (b) Ordnance stores and cooking utensils.
  - (c) Fire fighting equipment.
  - (d) E1 clothing.
72. Arrange two generating sets of 63 KVA and 31 KVA for RD camp.
73. Investigation of abnormal/untoward incident in the camp.
74. Arrange for ammunition and pyrotechniques for PM's Rally.
75. Arrange for training stores required for training/competitions as intimated by Training Dtes/MS Dte.
76. Arrange flag poles and Flags (National and DG NCC Flags).
77. Submit draft station orders for drawl of FOL, rations and also submit demands for the same.
78. Arrange radio sets AN/PRC -25 for RD camp including NCC run and PM's Rally.
79. Ensure arrangements for reception/adm of layout group/advance party.
80. Arrange sprinkling of water in the Camp and PM's Rally ground.
81. Consolidate requirements of rail reservations for return journey received from Directorates and place demands on Mil Rails.
82. Arrange for car flags and star plates of all Chief Guests and VVIPs visits as per their entitlement. For ceremonial parade, Service/National Flag will be arranged for additional flag pole on ceremonial review jeep.
83. Issue instructions to NCC Dte Delhi to demand tentage and other Ordnance stores/equipment for setting up the camp.
84. Place indent on HQ Delhi Area for the transport and working party or collection of tentage and other stores from COD Shakurbasti to camp site.
85. Assist NCC Dte. Delhi and the Camp Commandant in case of difficulties with regard to the provision and procurement of tentage, furniture, electricity, water and other stores.
86. Arrange stock taking of all stores purchased for the camp from various funds.
87. Attend to the following :-
  - (a) Minor/Major works.
  - (b) Leveling of Camp Area.

- (c) Arranging Flood/Security lights.
- (d) Laying of water pipes.
- (e) Barricading.
- (f) Provision of tiered stands.

88. Arrange for the saluting dias, red matting and flag pole for Camp Inauguration, Visits of VVIPs/Service chiefs, PM's Rally and other functions when required and also arrange its decoration.
89. After the RD Camp submit draft DOs to agencies that helped in organising RD Camp to RD Cell and on approval issue the same.
90. Liaise with HQ Delhi Area, Army Hospital and Base Hospital for provision of Medical Officer, Nursing Asst, Nursing Sister, equipment, medicines and ambulance vehicles for the Camp MI rooms (one each for boys and girls areas).
91. Make necessary arrangements for accommodation, furniture, rations and other adm requirements for RVC personnel and the horses and issue necessary instructions to Camp Staff. Also arrange manufacturing provisioning of jumps required for Horse Show.

#### **MS DIRECTORATE**

92. Detail Officers and PI Staff for RD Camp duties, Judges for RD Banner Competitions and Conduct of RD Banner Competitions including Best Cadet Competition.
93. Compilation of results of Competitions/Selections and submit to RD Cell for informing Directorates.
94. Prepare written question paper for best Cadet and National Integra-n competitions.
95. Issue of detention certificates to officers detailed for the RD Camp and PM's Rally duties.
96. After the RD Camp submit draft DOs to agencies that helped in organising RD Camp to RD Cell and on approval issue the same.

#### **P&F DIRECTORATE**

97. Detail civilian staff for RD Camp and RD Cell duties.
98. Arrange issue of typewriters for RD Camp and RD Cell.
99. Provision of passes for officers and cadets including foreign cadets for RD Parade and Beating of Retreat. A .
100. Arrange for funds for RD Camp and Operate Camp accounts.
101. Arrange audit of Camp accounts.
102. Submit points on General Achievements and Future plans for DG's opening Address to RD Cell.
103. initiate action for installation of Hot Line telephone and one telephone at Rally ground in consultation with JD Trg (Air). '
104. A Submit indent to CAO for stationery required for the Camp and RD Cell
105. Provision of flower pots from Horticulture Deptt, CPWD.
106. Provision of telephones, TV, PCOs, Cinema section, Post Office and Bank. Extension Counter at Camp site.

- 107. Preparation of Menu and arrange refreshments during function held in the RD Camp.
- 108. Arrange establishment of Shopping Complex.
- 108. (a) Detail GCIs Required for Camp duties.

### **P & C DIRECTORATE**

- 109. Finalise dates of visits of State DDsG to the RD Camp.
- 110. Initiate action to invite VVIPs to preside over various functions.
- 111. Bring the list of invitees up-to date and get DG's approval of invitee list for various Camp functions.
- 112. Arrange provision of invitation cards and car pass labels and dispatch invitation cards for various functions and handle acknowledgements.
- 113. Prepare seating plan and reception arrangements for inaugural function, ceremonial parades, cultural programmes, PM's Rally & Horse Show.
- 114. Organise ushering for all functions.
- 115. Organise escorts for VVIPs visiting the RD Camp. Escort will also report to Secretary RDC for briefing, and coord.
- 116. Ascertain the number of invitees attending the various functions and keep Camp Commandant/Secretary RDC/Refreshment Officer Messing Officer/informed.
- 117. Arrange for sign posting, security and traffic control including parking of transport for all functions including President's 'At Home' and PM's Tea.
- 118. Arrange security of VVIPs during their visit to the Camp including PM's Rally. Security arrangements for, each specified function be got approved by JD Coord from the DG personally.
- 119. issue instructions regarding wearing of dress during various functions in the RD Camp and bringing of identify cards by the cadets.
- 120. After the RD Camp, submit draft DOs to agencies that helped in organising RD Camp to RD Cell and on approval issue the same.
- 121. Organise publicity and Public Relations.
- 122. Arrange for the visit of Media Personnel through Dte of Public Relations for pre-view of the RD Camp.
- 123. Preparation and submission of background material for RD Camp, PM's Rally and RD Parade.
- 124. Setting up of Motivation Hall. Cadets for briefing the VIPs will be given by the Camp Comdt.
- 125. Prepare and print briefs on NCC Achievements and Programmes, RD Camp and PM's Rally.
- 126. Arrange for commentators for PM's Rally and Horse Show.
- 127. Issue rules and policy decisions regarding cultural competitions.
- 128. Organise and conduct cultural competitions/programmes and sub-mission of results.
- 129. Submit to MS Dte the names of lady whole time NCC officers to fill Camp appointments.
- 130. Organise presentation of cultural items during the President's 'At Home'.
- 131. Arrange judges for cultural competitions.

132. Arrange decoration of the auditorium stage for cultural programmes.
133. After the RD Camp, submit draft DOs to agencies that helped in organising cultural activities/competitions to RD Cell and on approval Issue the same.

### **DELHI DTE**

134. Prepare and conduct PM's Rally including Naval and Air Activities. Cadets for the following activities will, however, be provided by the agencies as mentioned against each :-

- (a) Guard of Honour - RD Camp
- (b) Para sail display - -do-
- (c) Cadets doing Gliding - To be detailed by JD Air, Dte Gen NCC from RD Camp.
- (d) Cadets displaying Aeromodelling. - -do-
- (e) March Past - RD Camp

135. To provide and be responsible for all the administrative arrangements South of Tarmac Saluting Dais, Garrison Parade Ground during the conduct of PM's Rally.

136. Correspond with IAF/Civil Aviation authorities for arrangements and clearance of items of flying and gliding and other aspects of the gliding and aeromodelling display during the PM's Rally at Garrison Parade Ground.

137. Submit draft minute to minute programme and draft commentary for the PM's Rally to Secretary RDC SC for approval of the DG.

138. Submit requirement of funds for the Prime Minister's Rally.

139. Setting up and upkeep of the Army Navy and Air enclosures of the Motivation Hall

140. Project requirement of seats for local school children/cadets for various camp functions.

141. Arrange for Fire Tender in Camp location w.e.f O5 Dec .

142. Demand tentage and other Ordnance stores required for the RD Camp from COD, Shakurbasti on behalf of the Camp Commandant as advised by Lgs Dte, Dte Gen NCC.

143. Arrange with Police authorities for provision of guards for Kotes, security of girls area and patrolling during night w.e.f. O2 Jan.

144. Provide items of clothing and necessaries for NCC officers, cadets and PI staff in case of urgent necessity as intimated by Dte Gen NCC (Lgs Dte).

145. Provide additional cadets for ushering duties for RD Parade and any other purpose as requested by the Ministry of Defence through Dte Gen.

### **DUTIES OF OTHER KEY PERSONNEL**

#### **Camp Commandant**

1. The Camp Commandant will work directly under DDG (Lgs) and will be responsible or overall command, smooth running and adm arrangements of the Camp including adm arrangements for competitions. He will ensure the following :-

- (a) Efficient execution/conduct of camp programme and instructions.

- (b) Provide staff, stores, resources and transport for all functions of RD Camp and PM's Rally.
- (c) Ensure good control over cadets and their conduct in camp and all connected functions including those held outside Camp.
- (d) Proper reception arrangements are made for the contingents on the railway station and for their transportation to the Camp.
- (e) Camp accounts are properly maintained.
- (f) Furniture, equipment and other stores required for Ceremonial Parades and other functions are procured through Dte Gen NCC and laid out well in time.
- (g) All functions planned to be held inside the Camp are properly organised and coordinated.
- (h) Issue of detention certificates to officers and staff detailed for the RD Camp duty.
- (j) An Aide-Memoire, covering some of the responsibilities of the Camp Commandant in detail, for guidance, are given at Annexure-I.

2. He will ensure that all camp officials carry out their duties efficiently and that the camp is run as an example of a model NCC Camp in all respects. He will particularly ensure the following:-

- (a) All competitions and functions planned to be held during the RD Camp are properly organised and coordinated.
- (b) Any untoward or abnormal occurrences are reported immediately to DDG (Lgs) & ADG(B).

### **Dy Camp Commandant**

- 4. (a) Assist the Camp Commandant in the discharge of his duties.
- (b) Act as security and fire fighting officer of the camp.
- (c) Act as PMC Officers' Mess and ensure efficient functioning of cadets messes.
- (d) To liaise with DD Publicity for various publicity requirements.
- (e) An "Aide Memoire" covering some of the responsibilities of the Deputy Camp Commandant in detail are at Annexure 2 or guidance.
- (f) Act as OIC PI Staff.

### **Camp Quartermasters**

6. They will work as staff officers to the Camp Commandant and will be in-charge of general administration of the camp. They will be responsible to maintain ration accounts and arrange for the timely supply of all rations, both dry and fresh. Visit cook houses, water and bathing points and latrines daily to ensure that they are clean and there are no sources of fly breeding around the Camp. He will ensure implementation of orders on hygiene and sanitation and cook houses etc.

### **Specific Before Arrival of Advance Party**

- 1. Liaise with HO Dte Gen NCC and collect all information relating to the Camp.
- 2. Find out from Lgs Dte as to what contracts have been finalised and what is the responsibility of the Camp.

3. Liaise with Ordnance Depot, Shakurbasti to check up whether indents and demands have been upgraded by them and whether these are being made available, especially with regard to tent poles, ridge poles and pages.
4. Liaise with HO Delhi Area, Station HQ and concerned GT Coy.
5. Make sure that the vehicles are made available as per demand.
6. Liaise with all concerned and ensure that all formalities are completed, namely publication of Station Orders, attachment of NCC vehicles for supply of FOL and drawing of rations from Supply Depot and so on.
7. If civil labour is to be employed for setting up of the Camp, check the sources from which such labour can be obtained and employed with permission of the Camp commandant.
8. Liaise with NCC Dte Delhi, to tie up arrangements for drawing tentage from Ordnance Depot, Shakurbasti. Also arrange to draw RD Camp stores from Delhi Dte and DGNCC RD Camp.
9. Engage dhobies, barbers, cooks and others, as per approved rates/contracts.
10. Consult Camp Comdt and ensure that essential personnel are employed on arrival of the advance party.
11. Assemble the Board for fixing up hiring rates in consultation with Station HQ.
12. Liaise with Cantonment Board and make arrangements for conservancy staff.
13. Arrange employment of sweepers for Camp.
14. Make sure that the cart removing the refuse does not pass in front of the Air Force Officers quarters adjacent to the Camp.
15. Liaise with the staff of HQ Delhi Area and Supply Points and arrange purchase of dry and fresh ration from Supply Depot.
16. Take over ancillaries and buildings from Lgs Dte before 07 Dec. Arrange repairs to buildings, ancillaries and drainage of the area by the MES. On termination of the Camp, hand over the buildings and ancillaries back to Lgs Dte through MES and arrange to make good damages to the buildings and ancillaries before 10 Feb.
17. Contact Lgs Dte to ensure that orders are placed on the approved contractors for supply of furniture to the following :-
  - (a) Advance and Rear parties.
  - (b) RD Camp including that mentioned at sub-para (a) above and for Officers Mess and Officers including Contingent Commanders.
  - (c) Auditorium .
  - (d) Aeromodelling
  - (e) Ship Modelling
  - (f) PM's Rally
  - (g) CSD and Wet Canteens
  - (h) Foreign cadets .
18. Contact Civil Supply Deptt of Delhi Administration and examine if atta, sugar and rice can be obtained at cheaper rates than those of Supply Depot. Also check samples of rations at Supply Depot, rates in the market and decide the source from which the fresh and dry ration should be purchased, keeping the quantity in view.

19. Arrange for the maintenance, documentation, security and detailing of vehicles till such time as the MTO arrives.
20. Ensure repair and cleaning of utensils. This will be completed before the arrival of the advance party. Prior approval of the Dte Gen NCC (Addl DG) is to be obtained before incurring this expenditure. I
21. Check price of meat in the Supply Depot/market and obtain from the cheaper source, keeping in view the quality.
22. Ensure collection of poles from MES as arranged by Lgs Dte and banners from Dte Gen NCC (Lgs Dte)

### **Specific duty on Arrival of the Advance Party**

23. Draw out a list of minimum requirements of stores which are to be purchased locally for the Camp and after the approval of Dy DG (Lgs), of Dte Gen NCC, arrange for local purchase.
24. Draw fire fighting equipment from NCC Dte Delhi.
25. Hold fire fighting practices regularly.
26. Ensure orders for fire-fighting have been issued to all.
27. Arrange electrification of tents, latrines, bathrooms, offices, auditoriums and streets. .
28. Arrange employment of carpenters, painter and masons in consult on with Camp Commandant.
29. Arrange purchase of disinfectants and other stores required for hygiene/sanitation of the Camp.
30. Arrange for supply of animal rations.
31. Arrange for drawl of tentage of synchronies with arrival of the advance party. Also draw dry and fresh rations.
32. Issue detailed orders to JCO-in-Charge hygiene/sanitation, JCOs-in-Charge furniture and ration laying down their specific responsibilities.
30. Arrange for medical examination of all civil employees in the camp.
34. Draw contacts for supply of hot water baths to cadets. Minimum number of hot baths per cadet is two per week.
35. Ensure proper hygiene/sanitation and cleanliness of Camp area especially in the area of cookhouses, urinals and latrines.
36. Arrange and obtain bedding for the foreign cadets from the Army Hospital in liaison with the ADMS, Delhi Area.
37. All the furniture hired from the contractors and other sources for the RD Camp, PM's Rally and other functions shall be handed over to the source of receipt complete in all respect.

### **MTO**

7. The MTO (Preferably an EME/ASC Officer detailed from one of the Dtes), will work directly under Col Logistics, and will be responsible for overall Command, and smooth functioning of the MT. He will report to the camp along with the Advances Party. The duties of MTO are enumerated below:-

- (a) He will control the MT in the Camp.



- (b) He will liaise with authorities concerned and in consultation with Lgs Dte of DG NCC ensure that all the formalities are completed regarding publication of Station Order for attachment of NCC -Vehicles for drawing of FOL and PM.
- (c) In addition to the drivers, he will be assisted by the following staff :-
- (i) Asstt MTO
  - (ii) MTO JCO
  - (iii) Electrician
  - (iv) Vehicle Machine
  - (v) FOL NCO
  - (vi) Clerk MT
  - (vii) Lascars - 2 (To be provided by Camp Comdt)
- (d) He will be responsible for drawal and accounting of FOL and Maintenance of VDRA's/Mileage cards.
- (e) The vehicles of DG NCC MT will be handed over to MTO RD Camp along with necessary documents on 31 Dec. The Vehs of DG NCC will be handed back on 01 Feb. A copy of Handing Taking Certificate duly countersigned by Col Logistics will be fon/warded to Logs (B-2).
- (f) Ensure first line repairs are carried out in the Camp, with the help of EME personnel detailed for the Camp and det from Static Workshop.
- (g) Liaise with Static Workshops to ensure R-2 repairs in respect of service pattern vehicles are carried out expeditiously.
- (h) Liaise with authorised civil workshops for speedy repair of civil pattern vehicles. Prior approval of Competent Authority is to be obtained before sending the vehicles to the civil workshops. Maruti vehicles will be got repaired at Maruti Company workshop at Naraina, New Delhi only. Other Civil pattern vehicles will be repaired at authorised workshops located nearest to RD Camp.
- (j) Ensure that requisition for vehicles are put up to Col Logistics by 1300 hrs the previous day duly vetted.
- (k) MTO will place indent for the vehicles on ST Branch, HQ Delhi Area one week in advance. He will liaise with HQ Delhi Area/GT Coy/Civil Contractors to ensure that vehicles ex HQ Delhi Area report in time.
- (l) Maintain proper IN and OUT register at MT Gate.
- (m) Ensure that the vehicles are utilised with utmost economy and all entries in the car diaries are completed by the users daily and signed by authorised persons. Duties so filled will be re-checked by MTO
- (n) Ensure that vehicles are used only for duties connected with Republic Day Camp unless in cases where it has been specially authorised.
- (o) Ensure that vehicles are not used between residence and place of work except in cases where it has been specially authorised. '
- (p) In case of accident the following will be notified by the fastest means and action taken by the MTO in accordance with AO on the subject :
- (i) Camp Comdt
  - (ii) Col Logistics



- (iii) DDG Logs
- (iv) ADG (B)
- (q) He will ensure that all vehicles, FOL and stores are properly protected/guarded.
- (r) He will put up daily MT parade state and MT Off-Road state to Col Logistics, DDG (Lgs) and ADG (B) as per Annexure 4 & 5 respectively.
- (s) He will hand overall documents of MT to MTO DG NCC with in 20 days on termination of the Camp. A copy of the Handing/Taking over certificate duly counter-signed by Col Logistics will be forwarded to Logs (B-2). Ensure that all MT documents are properly maintained and get audit done through LAO. He will also be responsible to ensure that all objections are settled and obtain a certificate to that effect from LAO within 20 days of termination of RD Camp.

### **Signal Officer**

8. He will be responsible for :-
- (a) All signal communications including the PA coverage for all parades and other functions including cultural programmes, in the Camp. PA Coverage for AT HOME at Rashtrapati Bhawan and DG'S House will also be arranged
  - (b) Arrangements for the internal broadcasting of news and announcements.
  - (c) Arranging the provision and operation of internal telephone facilities in the Camp.
  - (d) Maintenance and safety of all PA equipment hired for the Camp.
  - (e) Laying and establishing a Hot Line for Air events at the Rally.
  - (f) Maintaining close liaison with Delhi Area Sig Coy for efficient functioning of signals communications for all parades and functions.

### **OC Boy Wing**

9. (a) He will be responsible to the Camp Commandant for the administration and discipline of the boys contingents and PI Staff.
- (b) Ensure that the cadets report for the various functions and rehearsals at the appointed time.
- (c) Make certain that the contingent commanders check cadets for their turnout before they go for various parades.

### **OC Girls Wing**

10. She will be responsible to the Camp Commandant for the smooth running, administration and discipline of the girls contingents and GCIs. She will ensure that -
- (a) The cadets report for the various functions and rehearsals at the appointed time and place ;
  - (b) The Lady ANOs check the cadets for their turnout before they go for various parades;
  - (c) No unauthorised person enters the girls area.

**Messing Officers.**

11. They will be responsible for the following:-
- (a) Preparation of the menu in consultation with the Messing Committee.
  - (b) Cleanliness and tidiness of cook houses and dining halls at all times.
  - (c) Ensuring that all cooks are medically examined before they are employed in the cook house.
  - (d) Ensuring that the meals are served hot.
  - (e) Ensuring that no food is wasted.
  - (f) They will report to the Camp Quartermaster daily for any instructions regarding cooks and cook houses.
  - (g) On the days when the cadets go out for the RD Parade and the rehearsals at Vijay Chowk, ensure that meals are ready for issue to the cadets at the time and place decided upon by the Chief Training Officer. They will ensure that no litter is thrown out by the cadets and the place is left clean and tidy.
  - (h) Ensuring that adequate arrangements are made for :-
    - (i) Storage of drinking water.
    - (ii) Cadets to clean up their plates and utensils after food.
  - (j) Ensuring implementation of orders on hygiene and sanitation of cook houses etc.

**Accounts Officer**

12. (a) He will be responsible for the maintenance of cash & bank accounts in the camp under the directions of the Camp Commandant and DDG (P&F).
- (b) Check and maintain all documents concerned with expenditure, hiring and purchase of stores out of the incidental Grant.
- (c) Be responsible for checking and maintenance of all documents pertaining to the messing accounts.
- (d) At the end of the Camp, submit complete accounts with all relevant documents to the DDG (P&F) for audit by the Director of Auditor General Central Revenues, New Delhi, and shall be responsible for settlement of any audit objections.

**Cultural Activities Officers**

13. (a) Be responsible for all arrangements for the cultural and entertainment activities and their rehearsals in consultation with DDG (P&C) Dte Gen NCC
- (b) Liaise with DD (Pub) Dte Gen NCC for coverage of cultural and entertainment activities by AIFI/TV and other Organisations.
- (c) Arrange for the setting up of the auditorium and stage in the Camp and its proper lighting, laying out of furniture, stores, equipment required for the stage and conduct of cultural activities.
- (d) Prepare items for presentation at the time of the reception at the Rashtrapati Bhawan in consultation with DDG (P&C) Dte Gen NCC.

- (e) Ensure that a generator of capacity 63 KVA or more is available as a stand-by arrangement at the auditorium in case normal power supply is interrupted. The working of the generator will be checked every day and at least two hours before the function is schedule to commence to ensure serviceability.
- (f) Ensure that the PA equipment installed in the auditorium by the camp signal officer is in good serviceable condition.

### **Camp Medical Officer**

14. He is responsible for the following

- (a) Setting up of the MI Rooms at the Camp. \_
- (b) Liaison with HQ Delhi Area staff and OC Army Hospital/Base Hospital Delhi.
- (c) Attending sick parades of officers, cadets, and others.
- (d) Visit he cook houses, canteens, urinals, latrines, bathing places, water point, ration stores and Officers Mess daily to ensure proper hygiene and sanitation. .
- (e) Maintain the Sanitary Diary for the Camp and ensure that action on points needing rectification or improvement is taken expeditiously.
- (f) Advise the Camp Commandant on all matters concerning health, hygiene, sanitation and cleanliness in the Camp.
- (g) Ensure that the caloric value of the food planned in the menu is not below the minimum requirements of cadets keeping in view the extra strain that they are put to in the RD Camp.
- (h) Ensure that first aid arrangements are always available at the Parade Ground on days when parades/Fially are held including on rehearsal days.
- (j) Make sure that either he himself for a Lady Medical Officer is available in the Camp area at all times.
- (k) Ensure that the nursing officer and nursing assistants are aware of the emergency treatment to be given to following types of cases :-
  - (i) Burns
  - (ii) Electric Shock.
  - (iii) Giddiness and fainting on parade.
  - (iv) Snake bite.
- (l) Carry out medical inspection of the contingents on arrival and ensure that all ranks and cadets are free from infection.
- (m) Ensure that all cadets are weighed on their arrival and departure and proper records maintained.

### **Ship Modeling Officer**

15. The ship modeling officer is responsible to the Camp Commandant for all arrangements in connection with the following :-

- (a) Ship Modeling workshop tent.
- (b) State display tent.

- (c) Static tanks for working models, including water supply for the same.
- (d) Furniture and electrical fittings for (a) and (b) above and their layout.
- (e) Cleanliness and preventability of (a) and (b) above all times.
- (f) Procurements, display and safe custody of all built up ship/boat models brought by the Naval Wing contingents for display/competition and their return on completion.
- (g) Procurement, safe custody and re-issue under personal signature the modelling kits brought by the Naval Wing contingent for competition.
- (h) Overall supervision of the ship modelling workshop so as to ensure that the competitors participate effectively and without any unauthorised external assistance.
- (j) Muster all models and competitors as required for the ship modelling competition.
- (k) Preparation of score sheets as required for the competitions.
- (l) Close liaison with the Dte Gen NCC (Naval Wing) for the efficient conduct of the ship/boat modelling competition and display.

### **Officer IC Shopping Complex**

16. He will be responsible for the following :-

- (a) To ensure that the shopping complex is run efficiently and smoothly.
- (b) To constitute a committee or fixing the prices and for advice on the day-to day running of the canteen.
- (c) To maintain close liaison with camp medical authorities for the purpose a maintaining a high standard of hygiene in the Shopping complex.
- (d) Issue any other orders/instructions necessary for smooth functioning of the Shopping Complex.

### LIST OF CONTINGENT CLOTHING, STORES AND EQUIPMENT

1. Each contingent will bring following items on Directorate basis:-
  - (a) Line and Flag area stores - As listed in the competition rules.
  - (b) Sufficient rifle cleaning material to include the following-
    - (i) Pull-through complete.
    - (ii) Rifle oil.
    - (iii) Flannelette
    - (iv) Cotton waste.
  - (c) Rifle sling-1 per SD cadet.
  - (d) Petromax lamps-3 per contingent.
  - (e) Lanterns hurricane -1 per cent/8 cadets.
  - (f) Directorate Flag-3. Flag masts, pulley and rope will be issued by Camp Comdt.
  - (g) Sashes Red-Three.
  - (h) Rifle chains with locks-Sufficient for the number of rifle
  - (j) Items as required for cultural activities-such as musical instruments, costumes, make-up material and so on.
  - (k) Fire Fighting equipment as under:-
 

(i)	Fire buckets	-	16
(ii)	Fire beaters	-	4 (will be issued by (Camp Comdt.)
(iii)	Fire extinguishers	-	8
(iv)	Fire Hooks	-	4 (will be issued by Camp Comdt.
(v)	Shovels GS	-	4
(vi)	Axes hand	-	4
(vii)	Axes felling	-	4
(viii)	Axes pick	-	4
  - (l) Aero/Ship models as per DGNCC/Air/Navy instructions.
  - (m) Flag Area State Emblem and Quarter Guard stores.

**Notes:** An additional 10 percent of items of clothing and other accessories such as hackles, pompons, proficiency badges, mounted arm titles, boots, shoes, stockings, for use by cadets of all wings will be brought by each State Contingent, to meet any untorseen requirements during the Camp.

#### Personnel Clothing/Multi Dress

2. Each NCC Officer and cadet will bring the following items:-
  - (a) Personal dress (Civ clothing) both cotton & woolen including footwear.
  - (b) Mufti Dress

**Boys**

  - (i) Navy Blue Blazer
  - (ii) Gray Flannel/Norsted Trouser
  - (iii) White Shirt
  - (iv) NCC Neck Tie

(v) Black Nylon/Woolen socks

(vi) Black shoes.

**Girls**

(i) Maroon blazer

(ii) Saree/suit (colour at the discretion of the DDG concerned)

(iii) Foot wear .

(c) Bedding. -

(d) Toilet requirements as necessary

(e) Steel Boxes (Size 26"X 18"X13") duly marked.

**PT Kit/Dress**

3. All the cadets attending the camp will bring the authorised PT Kit and dress for NCC Hun issued by the Directorate.

**NCC Dress Items to be brought by NCC Cadets**

<b>S. No</b>	<b>Items</b>	<b>Cadets SD/SW/JD JW</b>	<b>Remarks</b>
1.	Head Dress	1	Beret dark green (single piece/Pagri dark green with NCC Cap Badge and Red Hackle.
2.	Arms Title	2	One-NCC with Dte embroidered in golden yellow silk thread on respective service colour woolen cloth background.  One-NCC in expanded form, embroidered in golden zari thread on respective service colour woollen cloth background.
3.	Badges of Rank  Chevrons/Epauletes	1	To be worn by eligible Cadets. These will be of zari strips.
4.	Proficiency Badges	1 Set	To be worn by eligible Cadets only. Authorised badges will only be worn and in the correct precedence as laid down in Enclosure 1 to this Annexure.
5.	Lanyard NCC colour	1	To be worn by all Cadets attending RDC.
6.	Leather Belt Black with NCC Buckle Crest	1	Leather belt White for Naval Cadets.
7.	Belt Web Waist Polished Black	1	Web Belt Polished White for Naval Cadets.
8.	Socks Black	2	
9.	Boots Ankle/Shoes Black	1	Shoes Leather Black for JD/SW/JW Cadets
10.	Jersey Woollen-Pullover	1	
11.	Rifle Sling	1	For SD Cadets only.

12.	Bags Kit Universal	1	
13.	Cape Waterproof	1	
14.	Blankets	4	
15.	Durrie IT	1	
16.	Shoes Canvas Brown	1	Shoes Canvas White for SW/JW.
17.	Vest Woolen	2	
18.	Seven sided RD Camp Badge	1	To be purchased by all Cadets at RD Camp.
19.	Stainless Steel Glass & Plate	1 set	
20.	NCC Scarf with Golden zan strip interwoven	1	
21.	NCC Karmarband with Golden zari strip interwoven	1	
22.	Spats (White Rexene)	1	Only for RD Parade and Guard of Honour.
23.	White Gloves with NCC Colour band on wrist	1	
24.	Name plates (Bil-igual) Black with White lettering .	1	

### ITEMS OF CLOTHING TO BE BROUGHT BY CADETS OF RESPECTIVE WINGS DIVISIONS

S. No	Items	Cadets SD/SW/JD JW	Remarks
<b>Army Wing</b>			
1.	Shirt Terricot	2@	@ Dtes may issue more number of uniforms. However 2 new sets will be held by each Cadet.
2.	Trousers Terricot Khaki.	2@	
<b>Naval Wing</b>			
3.	Tunic White (Terricot) with 5 buttons gold placed	2@	
4.	Trousers White (Terricot)	2@	
5.	Shirt White (Terricot)	2@	
6.	Socks Woolen dark Blue	2	
7.	Blankets White (Pairs)	2	SD Cadets only
8.	Stockings Woolen Black	2	

**Air Wing**

- |     |                       |    |
|-----|-----------------------|----|
| 9.  | Trousers LBG Terricot | 2@ |
| 10. | Shirt LBG Terricot    | 2@ |

**Girls Wing**

- |     |                       |    |   |
|-----|-----------------------|----|---|
| 11. | Shirt Khaki Terricot  | 2@ | SW Girls of Naval and Air Wing also be in possession of Shirts and Slacks Khaki Terricot. |
| 12. | Slacks Khaki Terricot | 2@ |   |
| 13. | Salwar White Cotton   | 2  |   |
| 14. | Kameez White Cotton   | 2  |   |
| 15. | Socks White           | 2  |   |
| 16. | Dupatta White Cotton  | 2  |   |

**Notes:**

1. Officers and GCIs will bring all items of dress as authorised.
2. Full Medals will be brought by Officers /GCI for ceremonial Occasions.

**WEARING OF LAPEL BADGES BY CADETS OF ALL WINGS****1. Lapel Badges**

Lapel badges will be worn by authorised Cadets, on the top of the left shirt pocket. The following will be ensured:-

- (a) Badges will be stitched on scarlet coloured silk cloth mounted on a cardboard backing of a size 15 cm length and 6 cm width. This will be secured to the shirt by means of pins.
- (b) The Badges will be worn in two rows with a maximum of 5 badges in each row. Total number of badges will NOT exceed 10; if it does, badges lower in precedence will not be worn.
- (c) Cadets having five or less badges, will only wear them in the upper row.
- (d) Senior most badge will be worn on the right edge (nearer to the shirt centre buttons).

**2. Special Awards/Badges**

- (a) Def Secretary/DG Commendation Badge: Gold/Silver Badges for Commendation cards will be worn on left hand pocket below the Lapel badge and above the pocket button. Cadets authorised to wear both the Commendation Badges will wear the Def Secretary's Commendation Badge nearer to the shirt centre buttons.
- (b) Power Flying/Gliding Badges: These will be worn 1.5 cm above the top of Lapel Badges. Cadets having both the Badges will wear only Power Flying Badge. Only Aluminum/ Brass white coloured Badges will be worn. This Badge can only be worn by those Cadets who have successfully completed Solo.
- (c) Para Training Badge; This will be worn 2.5 cm above the name tab. This Badge can only be worn by those Cadets who have successfully carried out 3 Para jumps.



- (d) RDC Seven sided Badge: This Badge will be worn on the right hand shin pocket, 2 cms below the pocket buttons. This Badge will be worn by all Cadets wef 05 Jan. .
- (e) Mountaineering/Skiing Course Insignia: Miniature axe/Insignia will be worn below left hand pocket button, similiar to RDC Badge. This Badge/Insignia will be worn advance Mountaineering/Skiing Course.
- (f) Proficiency Badges for Certificate Exams: These will be worn on the left arm.
- (g) Competition Medals: Miniature /Governor's Medal/DGNCC Camp Competition Medals will be worn along with Lapel Badges.

### 3. Order of Precedence of Medals/Badges.

The Medals/Lapel Badges will be worn in the following order of precedence:-

- (a) National Bravery Award.
  - (b) Competition Medals (DGNCC Camps/Governors Medal)
  - (c) Advance Leadership Course/Camp
  - (d) Attachment with Regular Units/Military Hospitals
  - (e) Mountaineering/Skiing Course
  - (f) Rock Climbing Courses/Camp
  - (g) Basic Leadership Course/Camp
  - (h) Nav/Vayu Sainik Camp
  - (j) National Integration Camp
  - (k) Blood Donation
  - (l) All India Trekking/Cycling/Sailing Expedition.
  - (m) Annual Training Camp (Max of one Badge to be worn)
  - (n) Dte level Adventure Training/Expedition.
4. No other Medals/Lapel Badges will be worn.
5. No other Medals/Lapel Badges will be worn All Cadets attending RDC would be in receipt of and authorised to wear one or more of the above badges. All Cadets will wear Medals/ Badges as authorised.

## SEQUENCE OF ACTIONS ON ARRIVAL AT RD CAMP & DUTIES OF CONTINGENT COMMANDERS

1. Submit arrival report and contingent strength to Camp Adjutant and LO, RD Cell.
2. Depute arms escort to deposit weapons and ammunition in Camp Kote and ammunition stores and dispatch them.
3. Handover four copies of Nominal Rolls to RD Cell, two copies to Camp Adjutant including one for use by CTO Staff and eight copies for Dir Coord.
4. Collect copies of latest Camp Programme issued by the Secretary RDC from the Camp Adjutant.
5. Ascertain from the Camp Commandant/Adjutant the allotment of living tents for various categories of the contingent and depute part time officers to take over respective tents and furniture.
6. Allocate cadets for each tent.
7. Send telegrams to Directorate reporting arrival.
8. Organise safe custody for cash, valuables, weapons and ammunition and controlled stores.
9. Get cadets Identity Cards authenticated from Camp Adjutant.
10. Familiarise himself and his contingent with the Camp Layout.

### DUTIES OF CONTINGENT COMMANDERS

1. Performance of Directorate Contingent depends to a very large extent on the Contingent Commander and his staff. It is, therefore, essential that contingent officers, PI Staff and GCIs are nominated at least five months in advance and their duties are clearly defined by the Directorate.
2. Some of the main functions of the Contingent Commanders are listed in succeeding paragraphs.
3. **Preparatory Action**
  - (a) Study in detail and make members of the Directorate Contingent aware of Standing instructions on RD Camp and competitions rules prior to departure of the contingent for Delhi.
  - (b) Satisfy himself that composition of the contingent is as per the Directorate General instructions.
  - (c) Satisfy himself that there is no deficiency in Contingent stores, clothing and equipment that the contingent is required to carry.
  - (d) Ensure that the Bank Drafts for Directorate's share of RD Camp Expenditure, including messing charges of NCC Part Time Officers, are sent so as to reach Accounts Officer (Pers/B&F) of DGNCC in his office at R K Puram, New Delhi by 10 Dec.

- (e) inform Camp Commandant RDC, Garrison Parade Ground, Delhi Cant-10 telegraphically, of expected date and time of arrival of contingent at Delhi/New Delhi and mode of travel.
- (f) Ensure that bio-data of Best Cadet Competitors and Youth Exchange Probable's is sent to reach DDG MS and DDG Trg respectively by 26 December.
- (g) Ensure that the NCO carrying the bio-data of Best Cadets also carry the detailed composition of the contingent as required vide Paras.
- (h) Plan the move so that advance party (one PI Staff) reaches Delhi on 26 Dec and contingent on 03/04 Jan.
- (j) Ensure that stores, clothing and equipment required competitions is carried with the contingent as wagon/truck carrying heavy baggage might get delayed enroute.
- (k) Check documents including Identity Cards, Kit, Uniform and accoutrements of each member of their contingent. Do not bank on making up deficiencies on reaching Delhi as required item/quantity and transport may not be available.
- (l) Assign specific duties to contingent officers, JCOs, NCOs, UOI/SMI and Cadet Appointments. .
- (m) Earmark cadets to be sponsored for various Cadet Appointments.
- (n) Prepare provisional list of Blood Donors out of SD/SW cadets as per number assigned by DGNCC.
- (o) Ensure that PI/civilian staff accompanying the contingent carry sufficient money to pay for meals and other needs at Delhi.
- (p) Make tentative allotment of Tents/Barracks to cadets. SD and JD Boys will not be mixed up.
- (q) During Pre-RD camp, practice cadets in table manners, community singing and saluting while marching. '
- (r) Ensure purchase of return journey tickets and securing of rail reservations for the return journey. -

#### **4. Actions on Reaching Delhi.**

- (a) Report arrival to Camp Commandant, Camp Adjutant and RD Cell and hand over copies of Nominal Roll of Directorate contingent.
- (b) Deposits Arms, Ammunition and other controlled stores in the Camp Kote.
- (c) Submit names of cadets recommended for Cadet Appointments and special duties to RD Cell by 05 Jan. .
- (d) Collect copies of the latest camp programme issued by Secretary RDC from Camp Adjutant and clarify and doubts on Camp schedule or competition Rules from Secretary RDC/OIC Competitions.
- (e) Familiarise himself and his contingent with the camp layout, camp organisation, DGNCC camp offices and competitions sites
- (f) Make all cadets write letters to their home.

(g) Laydown priority of work so-as to ensure that Flag Area and Tent Area are fully ready by due date.

## 5. Major Actions During the Camp

(a) Maintain constant liaison with the RD Cell and camp staff.

(b) Ensure that cadets detailed/nominated from his Directorate reach appointed place and time for various events properly dressed/equipped and punctuality is maintained at all times. Full use will be made of contingent officers, PI Staff and Cadet Appointments to ensure presence of cadets at various functions and their good conduct and behavior all through a function/event.

(c) Ensure adequate security of tents/belongings of all Directorate personnel and stores at all times. Additional security arrangements will be made during last four days of the camp.

(d) Keep control over cadets of special activities category of the contingent and Air, Naval and RVC cadets going out of camp for competitions/rehearsals.

(e) Maintain duty roster and a roster for cadets to ensure that all cadets get equal opportunity to attend functions with VIPs and sight seeing around Delhi on days indicated in camp programme.

(f) Make 'all adm arrangements including for photographer and refreshment, if required, for visit of his DDG and any Minister/Official of his State to RD Camp and keep Secretary RD Cell and Camp Commandant informed.

(g) Read notices on the Notice Boards near Adjutant's office at regular intervals (at least twice a day).

(h) Check uniforms of cadet selected for RD Parade and Guard of Honour and make up any deficiency especially of accoutrements.

(j) Arrange safe custody of all cups, prizes and certificates received by contingent and cadets. Record will be maintained and damage in transit prevented.

(k) Ensure that SMI/UOIs sit with girl cadets and Part 'I' me Officers PI Staff with boy cadets at all functions in the Camp Auditorium, so as to maintain discipline and decorum. Similar arrangements will be ensured whenever cadets are sent to witness Horse Show, Beating of Retreat, RD Parade etc including rehearsals.

(l) Ensure regular daily evening Roll Call and physical check of all cadets.

(m) Detail cadets with good handwriting to fill up RD Camp Certificates in Hindi for all cadets of the contingent.

(n) Ensure that cadets of their contingent, from small squad and march smartly whenever they are required to move from one place to another within camp.

(o) Ensure that cadets are adequately protected against cold but do not wear unauthorised/ill fitting items of clothing. Woolen under-garments and leggings should be used. Jersey woolen must be worn in the evenings and morning especially before and after NCC Run.

- (p) Male officers, PI Staff and boy cadets do not enter girls area between 6 PM to 6 AM. During day time OC Girls will be informed if any male/boy is required to go to the girls area.
- (q) Movement of girl cadets to boys area, QM Stores and Officers tents will be strictly controlled and when essential in organised party. There will be no such movement from 6 PM to 6 AM. Contingent Commanders will plan to move stores required for girls up to the gate of girls area by boy cadets.
- (r) Ensure that cadets clear off from shopping complex five minutes before the closing time.

## 6. **Actions Before Leaving RD Camp on Terminal on of Camp**

- (a) Inform dates of ETS and Camp Commandant of expected time of departure (ETD).
- (b) Collect camp certificates. .
- (c) Clear all outstanding dues including those of Canteen and Shopping Complex contractors and photographs.
- (d) Handover letter of thanks from cadets to Camp Commandant Secretary RDC SC.
- (e) Clarify all doubts about performance of Directorate in RD Banner competitions from OIC Competitions.
- (f) Sign voucher for any RD Trophies being taken with the contingent and hand over original to Adm Dte of DGNCC.
- (g) Deposit the following:-
  - (i) Additional items of uniform issued to RD Parade and Guard of Honour Cadets to RD Camp Stores.
  - (ii) Music Cards (if applicable) to RD Cell.
  - (iii) Furniture of Camp and Fire Fighting Equipment to Camp QM.
  - (iv) Training Stores if drawn.
- (h) Submit suggestions, if any, for future RD Camp and Competitions to Secretary RDC.

## 7. **Actions on Return to Directorate and Before Dispersal of Contingent**

- (a) Check that all cadets have received camp certificates and photographs (if ordered)
- (b) Take back and deposit all cash, clothing and stores issued on loan.
- (c) Submit report to Directorate including suggestions for improvements for future RDC.

**SOP FOR RECEPTION, USHERING AND SEATING  
ARRANGEMENTS FOR FUNCTIONS CONNECTED WITH  
NCC RD CAMP, PM'S RALLY, CULTURAL SHOWS  
AND HORSE SHOW**

**Aim**

1. To lay down the SOPs for reception, ushering in and seating of the invitees during the various functions of RDC.

**NCC RD CAMP INAUGURATION**

**Seating Plan**

2. Seating capacity for about 240 guests exists in the Flag Area for the Inaugural function. The seating plan is given at Sketch 'P'. Dir (Coord) is responsible for detailed seating plan and other seating arrangements.

**Reception and Ushering**

3. Organisation and Control: Dir (Coord) will be overall Officer Incharge for all seating, reception and ushering arrangements. He will be assisted by the following officers and staff detailed by the DDG (MS) and the Camp Comdt for the duties as shown against each :-

- (a) LO to Chief Guest One Lt Col.
- (b) Ushering Team No 1 for MA's of Foreign Missions
  - (i) Camp Comdt
  - (ii) Adjutant A
  - (iii) One NCC Associate Officer (AP) A
  - (iv) One NCC Lady Associate Officer (Bihar)
  - (v) Two boy Cadets - (AP & Bihar)
  - (vi) Two girl Cadets - (AP & Bihar)
- (c) Ushering Team No 2 for VCOAS & Army Officer
  - (i) Camp Comdt (Under Study)
  - (ii) Asst Adjutant
  - (iii) One NCC Associate Officer (Gujarat)
  - (iv) One NCC Lady Associate Officer (Gujarat)
  - (v) Two boy Cadets (Orissa & Gujarat)
  - (vi) Two girl Cadets (Orissa & Gujarat)
- (d) Ushering Team No 3 for Joint Secretaries and Civilian Guests
  - (i) DD Trg (A)
  - (ii) One NCC Associate Officer (J&K)

- (iii) One NCC Lady Associate Officer (Kar & Goa)
  - (iv) Two boy Cadets (J&K, Kar & Goa)
  - (v) Two girl Cadets (J&K, Kar & Goa)
- (e) Ushering Team No 4 for VCNS & Naval Officers
- (i) DD MS(C), Navy
  - (ii) One NCC Associate Officer (Kerala)
  - (iii) One NCC Lady Associate Officer (Kerala)
  - (iv) Two boy Cadets, Navy (Ker & MP)
  - (v) Two girl Cadets (Ker & MP)
- (f) Ushering Team No 5 for VCAS & Air Force Officers
- (i) DD Lgs (C), Air
  - (ii) One NCC Associate Officer (MP)
  - (iii) One NCC Lady Associate Officer (MP)
  - (iv) Two boy Cadets, Air (WB & TN)
  - (v) Two girl Cadets, (WB & TN) Y
- (g) Ushering Team No 6 for Senior Officers of Delhi Administration
- (i) Director, Delhi Dte
  - (ii) One NCC Associate Officer (Delhi)
  - (iii) One NCC Lady Associate Officer (Delhi)
  - (iv) Two boy Cadets (DL: & Pb)
  - (v) Two girl Cadets (DL: & Pb)
- (h) Ushering Team No 7 for Officers of Finance Defence and Ministry of Defence
- (i) JD (Fin)
  - (ii) One NCC Associate Officer (Mah)
  - (iii) One NCC Lady Associate Officer (NER)
  - (iv) Two boy Cadets (NER & Mah)
  - (v) Two girl Cadets (NER & Mah)
- (j) Ushering Team No 8 for Civilian Guests
- (i) JD (Pers)
  - (ii) Two NCC Associate Officer (Ori & Raj)
  - (iii) Two NCC Lady Associate Officer (Ori & Raj)
  - (iv) Two boy Cadets (Ori & Raj)
  - (v) Two girl Cadets (Ori & Haj)
- (k) Reserve
- (i) Two JCOs & Two NCOs
  - (ii) Four UOIs/SMIs

### **Ushering**

4. (a) All Officers and staff detailed for reception and ushering will be briefed by the JD (Coord) on their duties 48 hrs prior to the function.
- (b) The Officers detailed for ushering duty will be given a final list of the invitees and the seating plan explained to them on the ground.

- (c) Ushering will be done from the alighting point/car park areas to the actual seats. For this, separate ushers will be detailed for alighting point area and for actual seating enclosures.
- (d) Ushers will also escort guests after the function to their cars or for refreshment as the case may be. .
- (e) Ushering of Chief Guests, his/her escort and VVIPs will be carried out as given in SNCCO 1/S/94 Vol I.
- (f) NCC Cadets, UOIs/SMIs and "Lady Officers detailed for ushering duties will assist in reception and ushering work, as so detailed by the JD (Coord).

### **Dress**

5. All Officers will wear Winter Ceremonial No 1 dress. Cadets UOIs/SMIs and NCC Whole Time/Part Time Officers and PI Staff will wear their authorised ceremonial dress.

## **CULTURAL SHOW**

### **General**

6. Cultural shows are organised in the Camp Auditorium No 1. Seating arrangements are made for a strength of about 1700 spectators including Cadets. Seating Plan.
7. The seating plan is as per Sketch 'Q' attached, Seating arrangements will be done under the supervision of Dir (Coord). Seats earmarked for all VVIPs of the rank of Lt Gen/equivalent and above will be marked by name. Dir (Coord) is responsible for making detailed seating plan and all seating arrangements.

### **Reception and Ushering**

8. Organisation and Control: Dir (Coord) will be overall Officer Incharge for seating, reception and Ushering, He will be assisted by DD (Coord) in this function. DD (Coord) will be exclusively Incharge for sign posting and co-coordinating traffic control. The following Officers and Staff will be detailed by the DDG(MS) and Camp Comdt for the reception, seating and ushering duties:-

(a)	Team No 1 (For Row V-1), for Lt Gen/Equivalents/VVIPs		
(i)	Officer	-	2
(ii)	Associate NCC Officers	-	2
(iii)	Lady Associate NCC Officers	-	2
(iv)	UOI/SMI	-	1
(v)	Boy Cadets	-	2
(vi)	Girl Cadets	-	2
(b)	Team No 2 (For Row V2/V3) for Maj Gens/Equivalents		
(i)	Officers	-	2
(ii)	Associate NCC Officers	-	2
(iii)	Lady Associate NCC Officers	-	2
(iv)	UOI/SMI	-	2



- |      |             |   |   |
|------|-------------|---|---|
| (v)  | Boy Cadets  | - | 2 |
| (vi) | Girl Cadets | - | 2 |
- (c) Team No 3 (For V4/V5) for Brigs/Equivalents
- (i) Same composition as Team No 2
- (d) Team No 4 (For V4/V5) for Cols/Equivalents
- (i) Same composition as Team No 2
- (e) Team No 5 For A1 to A8
- (i) Same composition as Team No 2
- (f) Team No 6 For B1 to B8
- (i) JCOs
- (ii) NCOs
- (g) Team No 7 for 'C' & 'D'
- (i) NCC Associate Officer
- (ii) Lady NCC Associate Officer
- (iii) Boy Cadets
- (iv) Girl Cadets

### **Reception and Ushering**

9. Dir (Coord) will assign responsibilities to the Officers by name for various duties and brief them on ground at 1400 hrs one day before the event. The Ushers will carry out the following duties :-

- (a) Escorting VIPs and Officer Guest from Car Parks to their seats.
- (b) Ensuring that the guests occupy allotted seats in respective enclosures.
- (c) Other spectators for whom seats have not been earmarked by name are also guided to their proper enclosures.
- (d) Ushering will start from the gate/car park area and will not be complete till the guests are seen off to their transport after the cultural programme.

10. All ushers will assemble at 1700 hrs on each day of the function for final briefing.

11. The Camp Comdt will ensure the following :-

- (a) Detailment of Associate NCC Officers, Cadets and PI Staff for ushering duties.
- (b) Clearing of enclosures of seating.
- (c) Layout of furniture as per seating plan.
- (d) Detailment of Lascars/labourers for dusting the furniture.
- (e) Cleaning of mess toilets.

- (f) Detailing of 10 lascars/labourers with DD (Coord) for sign posting at 1300 hrs and 2000 hrs on each day of function.
- (g) Cleaning and watering of the Cultural Show Area, Car Park areas and the approach routes.

### **Dress**

12. Officers will wear lounge suit for the function. Cadets will wear authorised Mufti dress and Lad; Officers will wear appropriate dresses for the occasion. JCOs and NCOs will be in uniform. Ushers will wear badges which will be issued by DD (Coord).

## **HORSE SHOW**

### **General**

13. NCC Horse Show and Band display are held at the Harbaksh Stadium every year. About 6000 guests, invitees and spectators attend the show.

### **Seating Arrangements**

14. Seating arrangements are made as per Sketch 'R' attached. Reception, seating and ushering arrangements etc will be made under DDG(Trg), assisted by Dir (Coord). Reception and Ushering

15. Organisation and Control: Dir (Coord) will be assisted by DD (Coord) in these functions. The following Officers and Staff will be detailed by the DDG(MS) and Camp Comdt for reception and ushering duties :-

- (a) For V Enclosures - 8 Officers (Incl two lady Offrs).
- (b) For A/B Enclosures - -do-
- (c) For Foreign Attaché - 5 Officers (incl one lady Offr).
- (d) Girl Cadet Encl - Two lady officers, four UOIs/SMIs.
- (e) Army RD Contingent Encl - Three Officers, Four JCOs.
- (f) Boys Cadet Encl - Three Officers, Four JCOs/NCOs.
- (g) DGNCC Staff/Camp Staff Encl - Two Officers, Four JCOs.

16. Dir (Coord) will assign duties to the officers by name and brief them in the Stadium at 1300 hrs one day prior to the show. Ushers will carry out their duties as given in Para 4 above.

### **Dress**

17. The dress to be worn will be as follows:-

- (a) Officers - Lounge suit/Blazers with tie and flannels.
- (b) Cadets - Mufti
- (c) Lady Officers - Appropriate to the occasion.
- (d) JCOs/NCOs and equivalents - Uniform

**PM's RALLY****General**

18. PM's Rally is the main event of the RDC and is the focus of all preparations. It is held on 27 Jan every year in the RD Parade Ground. PM is the Chief Guest and a very large number of VVIPs, VIPs, Foreign Dignitaries and other guests attend the function. Arrangements for 8000 to 9000 spectators are made. This requires a very high level of coordination and control for the seating, reception, ushering, traffic control and security arrangements for the occasion. Seating Plan.

19. Broad seating plan and schematic layout for the PM's Rally is given at Sketch 'S' attached. Detailed seating plan for the VIP enclosures will be made two days before the Rally and issued to all concerned. Dir (Coord) is responsible for making detailed seating plan. Reception and Ushering

20. Control & Coordination Cell: It will comprise of the following officers :-

- (a) Dir (Coord) - Officer-In-Charge
- (b) DD (Coord)
- (c) One Major/Lt Col - To be detailed.
- (d) Invitation Cell Personnel with  
One radio set

21. Escorts (LOs for the VIPs)

- (a) One Maj for the Def Secretary.
- (b) One Maj & three other  
officers (Civil/Military) - for Members of Parliament.
- (c) One Civilian Officer - for tribal Chiefs.
- (d) One to two Officers - for any other dignitary as  
may be required.

22. Ushers: A large number of usherers are required for this function Officers will be detailed by name, seven days before the Rally. Ushering Teams will be created for Right & Left Half. One OIC for Car Park will be nominated in addition to OIC Entry Gates.

25. Transport: Transport as required for the occasions will be detailed by the DDG (Adm). Details will be given later by Dir (Coord) by 21 Jan to the DDG (Lgs). Dne open jeep and 2 DHs will be detailed for sector control and traffic control duty to operate under direct control of Dir (Coord).

26. Ushering: Dir (Coord) will hold ushering conference at 1500 hrs on 22 Jan on the Parade Ground near the Saluting Base. The following will attend :-

- (a) Senior ushers of right and left half.
- (b) Usher in-charge each enclosures/car parking area.
- (c) Contingent Commanders, Lady Officers, SMLs/UOLs and one cadet appointment of each contingent.
- (d) Camp signal officer.
- (e) Camp Comdt/Adjt
- (f) Officer-In-Charge gates.
- (g) Camp MTO

27. General principals of ushering are the same as for the other functions. All ushers will be issued with recognition badges to be worn on the right pocket over the pocket button. These will be collected from DD (Coord).

### **General Instructions**

28. The Lgs Dte will ensure that furniture is laid out by 1500 hrs on 25 Jan as per the detailed seating plan. VIP dais will also be got ready by 1300 hrs on 26 Jan.

29. The Camp Comdt wil ensure the following:-

- (a) All gates except the NCC gate will be locked at night of 26/27 Jan and NCC gate will be manned on that night.
- (b) Bath-rooms are opened and cleaned by 0730 hrs on 27 Jan.
- (c) Water is sprinkled in car park areas during the evening of 26 Jan.
- (d) Two teams of 10 lascars under a JCO- incharge are detailed with the dusters to clean the sofa and chairs. They will report to the Senior Ushers of each half at 0730 hrs on 27 Jan.
- (e) Enclosures will be properly security guarded on the night of 26/27 Jan to prevent any unauthorised occupation of the seats.
- (f) Contingent team wil consist of the Contingent Commander, One Lady Offr, One SMI/UOI and 20 cadets (10 boys & 10 girls) except where stated. All will be in position by 0730 hrs on 27 Jan.

30. DD (Coord) will be the OIC Traffic Control. He will ensure that sign posting for car parks, enclosures and areas outside the Parade Ground is completed latest by 0600' hrs on 27 Jan. Camp Comdt will detail 10 civilian labourers to assist him in making the car park areas and putting up Sign Boards on 24 Jan.

**CHAPTER -II****ADMINISTRATION, FUNDS AND ACCUNTS****PART-I ADMINISTRATION****General**

1. This Chapter deals with clothing, equipment, and necessaries, responsibility for providing stores, accommodation, messing, medical care, canteen facilities, move to and from the Camp, reception, transport, discipline, security and all other aspects of administration during the Annual Republic Day Camp at Delhi.

**Administrative Control**

2. DDG (Lgs) and the Camp Comdt of the RDC, under overall supervision of Addl DG (B), will exercise administrative control over all personnel in the Camp.

**Accommodation**

3. All contingents will be accommodated in previously earmarked living accommodation area in the Camp. Earmarking of areas will be done under the aegis of Lgs Dte. Requirements of tentage, ordnance stores including firefighting equipment will be intimated. by Directorate General NCC (Lgs Dte) to all concerned. DDG Lgs, will be responsible for demanding all the above stores from OD Shakurbasti. NCC Lgs will ensure that all such demands for loan stores reach HQ Delhi Area (Q Branch) by third week of August every year at the very latest, as this is a lean period & sanctions ipso facto are easier to process. All stores will be collected by the Camp QM from Ord Depot Shakurbasti on behalf of Delhi Dte. Transport and the working parties will be arranged by the Camp Comdt in consultation with the Lgs Dte who will be responsible for procurement of transport. Details are given in the succeeding paras.

4. Girl cadets will be accommodated in separate walled area within the main Camp. They will have their separate messing arrangements. The foreign cadets, too, will be accommodated in a separate area. They too, will have separate arrangements for their messing. Boy cadets other than the foregoing, will be accommodated in the area so earmarked with integral administrative facilities.

**Layout Plan**

5. The lay out will be strictly adhered to by all concerned at all stages of the Camp.

6. The Lgs Dte will liaise with HQ Delhi Area/Station HQ Delhi Cantt/SHO Delhi Cantt and settle all matters pertaining to NCC RD Camp site/area by second week of August, every year. Completion report to this effect will be rendered by DDG (Lgs) to Addl DG(B) by the first working day of the third week, and weekly progress thereafter.

## Ancillaries

7. Ancillaries like bath rooms, cook houses, and latrines are already provided/existing on the camp site. Lgs Dte will check all ancillaries before commencement of Camp and ensure they are functional in all respects by 15 December. Thereafter, high standard of maintenance will be ensured. All ancillaries and buildings shall be taken over by the Camp Quarter Master from Dte before 07 Dec. These assets shall be handed over back to Lgs Dte on termination of the Camp. All damages shall be made good before 10 Feb in consultation with MES Rep. Clearance from MES to this effect shall be obtained by Camp QM and submitted to Lgs Dte by 15 Feb.

### Minor/Major Works

8. DDG (Lgs) is responsible for projecting and ensuring timely execution of Major Works concerning NCO RD Camp/site/area.

9. For the above purpose, he will approach HQ Delhi Area/MES for completion of works in hand. The proposed work at RD Camp will be projected by last week of July and DDG (Lgs) will lay down firm PDC's in consultation with HQ Delhi Area/MES with the aim of completing the work by end of November.

## Furniture

10. Requirement of furniture will be ascertained from the users and consolidated by Lgs Dte. MES is responsible to provide all authorised furniture. A demand for supply of all items of furniture will be placed on MES during July. NA Certificate will be obtained from MES. On the authority of the NA Certificates, a Board of Officers from the Dte Gen will be convened in the month of August by Lge Ute to review the requirement of furniture for the Camp. Representative of Lgs/Trg/Navy/Air/ and NCC Dte Delhi, for PM's Rally will be members of the board. Board proceedings after the approval by Addl DG(B) will be processed by Lgs Ute and action to hire items of furniture from the approved contractors will be taken for hiring of the recommended furniture. Wide publicity through the medium of news papers will be given to invite quotations during the month of September.

11. Tenders will be opened by a Board of Officers so detailed by Dir Coord. On acceptance of the tenders the intimation with full details will be sent to the contractor (s) to enable him/them to make preparation for supply of required furniture for various events. Specific dates will be mentioned in the supply order or strict compliance.

12. A complete list (schedules) of furniture (with accepted rates) with a copy of acceptance letter and other instructions will be sent to Camp Quartermaster. All the hired furniture, including that required for PM's Rally, will be taken over by the Call/I (Furniture) in serviceable condition & returned in same condition to the contractor on specified date, The Camp Commandant will certify for the correct receipt of all furniture schedule wise and submit all the bills on account the furniture to Lgs Dte. Having processed these bills Lgs Dte will forward these to P&F Dte for payment out of RD Camp grant.

13. List of furniture required for various occasions and purposes will be reviewed by DDG (Lgs) each year.

## **Auditorium**

14. Main auditorium will be erected and furnished under arrangements of the Dte Gen (Lgs Dte). The seating plan will be prepared by NCC/Coord and approved by Addl DG (B). The Camp Commandant will ensure proper arrangements/layout of furniture in the auditorium for all cultural activities. Second auditorium may be erected which will be used for cultural practices/screening movies/lectures by Guest speakers/Trg of uncommitted cadets.

## **Electrification of Camp**

15. Adequate number of electric points are provided by the MES. No unauthorised installation of lights or electrical appliances is permitted. A check to this effect will be carried out by the Camp Duty Offr, so detailed by the Camp Comdt from time to time, and include in the Duty Officer's report. Strict electric & Water discipline shall be enforced in the Camp by the Camp Commandant (with the help of Duty Officer & Contingent Cdrs). Installation of siren will be installed in the Camp to give Time Signal in particular for lights out and for fire fighting practices.

## **Hygiene and Sanitation**

16. Orders on hygiene and sanitation are at **Appendix A**. Payment for sweepers and consonance services will be made by the Camp Comdt out of camp funds. It is emphasised that hygiene and sanitation aspects assume greater importance in the camp. Camp Comdt will instruct Medical Offr to carry out regular checks. SHO Delhi Cantt will be approached by Lgs Dte for spraying of pesticides/insecticides in the area.

## **Civilian Labour.**

17. Civil labour will be employed by the Camp Commandant for setting up, maintenance and winding up of the camp at the prevailing nerrick rates. Dte Gen (P&F) will obtain the sanction of the Govt. for the employment of labour by the 1st Sep every year. Every day the payment will be made by the A0 (RD Camp) in presence of one officer and one JCO nominated by the Camp Commandant by publishing the names of the nominated officer in CRO. Camp Office will submit daily to the A0 (RDC) muster roll of the labourers employed during the day.

## **Clothing and Equipment**

18. Items of clothing and equipment and other necessaries, to be brought by all concerned are given at **Appendix J to Chapter I**. However, instructions regarding any change/additional items will be issued by Dte Gen (Lgs Dte) by August every year.

19. Each NCC Dte will ensure that cadets selected to attend this camp are equipped with two sets of terrycot uniforms. It is emphasised that the cadets uniforms should be properly stitched/fitting. The bottom of the trousers should vary between 14.5 "to 16" depending on the height of the cadet but in no case it will be other than this specification. The cost of alteration of uniforms will be met from the funds allotted for repair/refitting of uniforms.

20. Month of Jan is quite cold in Delhi and all personnel will be equipped with adequate warm clothing before they leave for Delhi. This will be ensured by each NCC Dte.

21. An additional 10 percent of clothing items such as, accessories, hackles, pompoms, badges, shoulder titles, boots/shoes, socks and stockings for use by cadres of all Wings will be brought by each state contingent to meet unforeseen requirements during the Camp. .
22. Ordnance Stores will be demanded on time, collected and properly accounted for.

### **Messing Arrangements.**

24. Messes The following Messes will be set up by the Camp Commandant:-
- (a) Officers' Mess (For Service Officers and Whole Time Lady Officers).
  - (b) JCOs Mess
  - (c) PI Staff Mess
  - (d) Messes for cadets (Separate for boys & girls)
  - (e) Foreign Cadets Mess
  - (f) ANO Mess
25. Respective Messing Officers will exercise control over the cooked food and its correct distribution to the authorised personnel. Plastic discs already procured will be used. Distribution of food will be supervised by a JCO/NCO detailed by the respective contingents. It shall, however, continue to be the responsibility of Messing Officers to ensure efficient arrangements in this respect.
26. It will be ensured that Officers, JCOs, GIs, NCOs and civilian staff detailed for the Camp bring requisite sum of money to pay for the messing charges during the Camp. All bills will be cleared before conclusion of the Camp. No civilian Dhaba will be established. Civilian may dine in the Camp Staff Mess and pay the same messing as in the case of Cadets/Camp Staff.
27. Daily expenditure on messing will be displayed prominently in the Camp as per format given in DG NC letter No 2987/NCC Pers (B&F) dated 11 Feb 74 at **Appendix B.**
28. Rations for the Camp will be drawn from the Sup Depot on the authority of Army HQ, QMG's Branch letter No 41739/ST6B/ dated 3 Jan 1958 as amended by letter dated 13 Aug 60 and in accordance with Para 4 (Part III) of the "Instructions on the Maintenance of Camp Accounts". Indents will be placed through the DDST, HQ Delhi Area.

### **Drawl of Rations**

29. Dte Gen NCC (Lgs Dte) will submit draft station order by second week of November for drawl of rations and also submit demand for the same.

### **Cook Houses**

30. Utmost attention will be paid to cleanliness and hygiene. Standing Orders for cook houses are given at **Appendix C.** Standard Cooking Hangs already existing (on temporary basis) are preferable than conventional chullahs for the following reasons:-
- (a) A Cooking conditions for the cooks are more comfortable.



- (b) Economy in fuel
- (c) Anyone of coal steam/coke soft/firewood as available can be used
- (d) Kitchens can be made smoke free by means of providing improvised chimneys to such cooking ranges.

### **Cooking Utensils**

31. A number of cooking utensils are already held and are on the charge of DGNCC Camp for this purpose. These will be drawn by the Camp QM before the arraival of Advance parties. Any additional quantities required will be hired locally by the Camp Comdt.
32. Items of crockery, if required, will be hired locally by the Camp Commandant and paid from the Officers Mess account. Approval for the same will be obtained in time.

### **Austerity**

33. Strict austerity measures of all kind will be enforced in the Camp. Particular attention will be paid to ensure that there is no wastage of food. The following will be ensured:-
- (a) The cooked food will be wholesome and adequate but elaborate bill of fare will not be arranged. Caloric value of food will be kept in mind while preparing the daily menu.
  - (b) Officers will frequently visit the cook houses and dining halls to check that there is no wastage of food.

### **Medical**

34. Provision of medical cover is in accordance with Ministry of Defence letter No O210/64-65/NCC-Pers(A)/1082/B/D(GS-VI) dated 19 April 1965 read in conjunction with Dte Gen letter No 210/63/64/NCC/Pers(A) dated 06 August 1965.
35. A medical officer for the Camp will be detailed by the DG NCC (MS). Medicines and equipment including ambulance required for the Camp will be arranged by Deputy DG (Lgs) from Base/Army Hospital Delhi Cantt for which approval of ADMS, Delhi Area will be obtained. To assist the Camp Medical Officer, three AMC NCOs from NCC Medical units will be detailed by Dte Gen NCC. A Lady Medical Officer and a nurse will also be detailed by the Dte Gen NCC (MS) for the Camp. Arrangement for provision of six beds will also be made.

### **Transport**

36. Transport for use during RD Camp will be arranged by Dte Gen NCC (Lgs Dte). The details of number of vehicles required on various days of the Camp will be worked out by Lgs Dte. The number of vehicles to be requisitioned (ie No of vehicles x No of days) from State Directorate will be done in advance. Adequate funds for hiring of transport will also be provisioned, well in advance.

37. (a) Allotment of transport during RDC for important duties will be done in advance. Balance vehicles will be kept in pool and will be allotted on requisition. Sub-allotment of transport within the respective Dtes will be the responsibility of respective DDsG. Vehicles required for Pub will be issued by 01 Dec based on RDC Major Events schedule.
- (b) Requisition of additional transport will be forwarded to MTO at least 48 hours in advance. The requisition will be put up in duplicate as per **Appendix D**
38. Vehicles ordered for attachment to RD Camp are detailed from Dtes. DDsG NCC of States will make sure that the the vehicles nominated for attachment are in roadworthy condition and drivers are briefed on the discipline aspect as also their loyalties to the performance of duties. DDsG NCC Dtes will as sign the Road worthy Certificates in respect of all the vehicles detailed from their Dtes.
39. Instructions for provisioning of transport for use during RD Camp from Delhi Area, Army HQ Pool and from internal NCC sources as per requirement as laid down in preceding paras will be issued by sec ond week of September, by Dte Gen NCC (Lgs Dte) after approval of Addl DG (B).
40. The repair facilities for vehicles in the RDC will be provided by Stn Wksp/Army HQ Static Workshop under arrangement of DDG (Lgs). In addition, EME personnel posted in NCC Units and detailed on the Camp will carry out first line repairs.
41. FOL will be drawn from ASC on the authority of Govt of India letter No 5629/NCC/Coord (B)/2366/US/D (DG-III) dated 25 Sep 62. Sufficient quantity of petrol should be kept in store to cater for the Camp requirement on non-petrol issue days and during last days of month. Account for expenditure incurred on FOL during the camp, though not debatable to camp account, will be maintained in separate register. This register will briefly indicate the daily mileage done by each vehicle, nature of dally duties performed, quantity of FOL and cost thereof.
42. Lgs Dte, will submit draft station order for drawing FOL and submit demands for the same by 15 Nov.
43. Indent. for rations/FOL to Supply Depot will be submitted by Lgs Dte by 05 Dec.

### **Drivers**

44. Drivers that accompany the vehicles coming from NCC sources will be attached to the Camp. They will make their own messing arrangement till the start of the Camp and thereafter "may dine in the Camp Staff Mess and pay the same messing as in the case of Cadets/Camp Staff" NCC Directorates providing these drivers will pay them advance of daily allowance. Drivers detailed by the NCC Directorates should preferably be those who are acquainted with the main landmarks of Delhi.

### **Documentation**

45. All documentation with regard to the use of vehicles and FOL accounting will be done according to the orders prevalent in the Army. Copies of duty slips/car diaries covering all duties in

the camp will be provided to the Directorates providing the vehicles by the Camp MTO on conclusion of the Camp.

46. In addition to the above, complete record of the meterage done by the vehicle for camp duty will be maintained by MTO/Astt MTO separately for each vehicle, attached to the Camp. This meterage record will be put by the MTO for perusal by DDG (Lgs) every Monday.

### **Loan Issue of Water-Trailers**

47. NCC Dte Delhi will arrange for procurement of eight Water Trailers of 1000 liters capacity each from local Army formations for a period not exceeding eight weeks during NCC Republic Day Camp. Govt sanction for obtaining the water trailers on loan has been accorded vide Govt of India, Ministry of Defence letter No 6871/Loan/WT/DGNCC/Adm (C) dated 17 Aug 79

48. Lgs Dte is responsible for arrangement of water trailers. In order to procure the same well in time a request will be initiated by Lgs Dte by first week of August every year and NCC Dte Delhi will be intimated to take follow up action in the matter.

### **Canteen - CSD**

49. A CSD (I) canteen will be established and run in the camp under the orders of the DDG (MS). Stocks of CSD(I) items will be obtained from the Dte Gen NCC CSD canteen. SOP is attached at **Appendix E**.

50. Adm Dte will place orders for stocking Camp CSD (I) Canteen with accoutrements, badges/medals, blood donation badges etc. Expedition medals (mountaineering, trekking, cycle & sailing) and medals plates for display of badges (as per specifications) given by JD Coord.

51. To procure items like badges/medals etc. quotations will be called for by the Lgs Dte in the month of Sep/Oct from the dealers and items will be arranged on competitive rates. A wide publicity for calling tenders will be given.

52. Non CSD items like stationary, NCC badges of rank etc. will also be arranged by P&C Dte and sold in the Canteen.

### **Wet Canteen and Shopping Complex**

53. Wet Canteen and Shopping Complex arrangements will be made by DDG(P&F). The aim will be to provide hot beverages and snacks prepared under clean and hygienic conditions and sold at rates cheaper than any other canteen in the area.

54. In the Shopping Complex, Snack Bars, Soft drinks, Milk, Ice Cream and Idli/Dosa Shops will be established.

55. For running the Regimental Shops, quotations will be called for by the P&F Dte from the interested parties, in the month of September every year. A wide publicity through advertisement in Newspapers to invite tenders from the maximum possible parties will be given along with the tender notice for furniture.

56. The distribution of items to be sold by the above shops will be decided by OIC Shopping Complex with the approval of DDG. (P&F).

57. The selling rates for items to be sold by the contractors at Regimental Shops will be fixed by a Board of Officers taking into consideration the prevailing rates of items in the market, and keeping in view the quality of the items. .

58. Afer the contracts have been concluded, the successful contractor will be informed to establish/open his shops before the Camp starts. Camp Comdt will suitably be advised to hand over the site/accommodation, tentage/furniture etc. SOP for shopping Complex is at **Appendix F**.

### **Office Equipment and Stationery**

59. A servicable duplicator will be provided to the Camp Commandant by NCC Directorate Delhi w.e.f 15 Dec. The operator will be provided by the Pers Dte/DG NCC.

60. Requirements of stationery will be arranged by the P&F Dte (Estt Branch) from the Chief Administrative Officer, Min of Defence. Sufficient number of clerks will be detailed by the Pers Dte for Camp offices. The clerks so detailed will bring English language typewriters from their Directorates.

61. Service labels will be arranged by the Pers Dte and handed over to the Camp Adjnt by 15 Dec.

62. Bins for litter will be obtained by Camp Commandant from the Cantonment Board. It will be brought home to all cadets that throwing of litter is not a good form of training of an exemplary citizen. The cadets should feel responsible as good citizens.

### **Move to the Camp**

63. Responsibility All arrangements for the move of the cadets to camp by rail/road will be made by the NCC Directorate concerned. Directorates will ensured that rail/road accommodation is arranged well in time. It is pointed out that due to paucity of rail accommodation, rail reservation may not be available unless it is made suficiently well in advance.

### **Discipline Whilst on Move**

64. Cadets will travel as an organised party during their journey to and from the Camp. A Contingent Commander will be appointed and will be made responsible for the contingent. Special attention will be paid to the following:-

- (a) Correct entraining and detraining drill when travelling by train and correct embussing and debussing drill if travelling by road. Individual cadets will not be permitted to detrain or debus without orders.
- (b) Discipline and courteous behavior throughout the journey.
- (c) Smart and correct turnout at all times.
- (d) Cadets will not be permitted to leave the railway platform except as an organised body.

(e) While leaving the Camp for railway station it will be ensured that drill for embussing and debussing is properly organised and strict discipline is maintained. During the move to the railway station, Contingent Commander will personally supervise the move of cadets and proper MT discipline.

(f) A senior NCO will be placed incharge of cadets in each compartment to ensure that the cadets do not lean out of the windows of the compartments, do not stand on footboards or in the open carriage doors and the doors & windows are closed and bolted while the train is in motion. Before entraining at stations where there are long halts the Contingent Commander will take an 'all correct' report from the NCO-in-Charge of each compartment.

65. **Medical Arrangements** For serious cases requiring medical attention, during journey, the Contingent Commander will contact the train Conductor/Guard and ask for assistance from railway medical staff it & when needed.

66. **Security of Arms**

(a) The Contingent Commanders will be responsible to ensure. the security of arms which are brought by each contingent. The Contingent Commander from each Directorate will be given clear orders about this in writing by the Deputy DG NCC concerned for strict observance during journey (both ways).

(b) The Contingent Commanders will be personally responsible for safe custody of the arms and stores and will ensure that they are properly guarded by day & night. The arms will be checked before leaving the Camp and also before entraining, at long halts and after detraining at destination.

67. **Feeding Arrangement Enroute**

(a) Contingent commander of each contingent will be responsible to arrange meals and refreshments for the cadets enroute. They will ensure that all members of the Contingent are properly fed and that the bills are cleared. No cadets will consume anything enroute from unauthorised hawkers. They will drink water only from authorised sources under the supervision of the Contingent Commanders. Vigilance against food poisoning is essential.

(b) While leaving RD Camp, respective Messing Officers will be responsible to provide hot haver sack meal depending on the time of departure of the train. He will also intimate to the authorities at the intermediate railway stations where meals will be required, giving details of vegetarian/non-vegetarian meals re quired. Contingent Commander will be responsible to contact and arrange the food at those stations & for clearance of bills before departure of the train.

68. **Intimation Regarding Arrival**

(a) Details of the Train and time of arrival of each contingent will be intimated by the Directorate concerned direct to the Camp Comdt. NCC RD Camp, Delhi Cantt with a copy to the DG NCC (Lgs Dte) latest by 01 Jan.

(b) The Camp Commandant will make necessary arrangements for reception of the contingents at the railway station and their move to the Camp. Every contingent will be met

by an Officer and a JCO to be detailed by the Camp Comdt. Depending on the time of arrival of the contingent, arrangements for serving hot tea will be made by the Camp Commandant. Contingent Commanders will report to the Reception Centre in the Camp immediate on arrival.

### **Reception Arrangements at Destination (on return)**

69. The Camp Commandant will send telegraphic information about the time and date of arrival of each contingent at their destination Railway stations to their respective Directorates. NCC Dtes concerned are responsible for making all arrangements for the reception of their contingents.

70. Arrival Report On arrival at their destination the Dtes will telegraphically send arrival report to the DG NCC (Lgs Dte).

71. Discipline in the Camp Strict discipline will be enforced through out the Camp. Particular attention will be paid to the turnout of the cadets both on and off parades. Camp orders issued separately, will be adhered to by all members including cadets, without any compromise whatsoever. Daily routine orders will be issued by Camp Comdt to ensure highest standard in all facets of the Camp.

72. Embussing Debussing While embussing, debussing and during move by MT, proper discipline will be maintained. One NCO from PI Staff will be incharge of each vehicle. He will ensure that the vehicle is not overloaded and that the drivers observe the prescribed speed limits. A standard drill for embussing and debussing will be evolved and will put across to the cadets through a demonstration arranged by the Camp Commandant. Camp Comdt/Contingent Cdrs will ensure that NOT more than 22 cadets are accommodated in the body of one 3 ton vehicle.

### **MT Vehicles and Drivers**

73. MTO will ensure that the vehicles attached to the Camp are used economically and efficiently. The drivers will be given particular instructions with regard to the following:-

- (a) MT discipline.
- (b) Road étiquette
- (c) Speed limits as authorised.
- (d) Overloading.
- (e) Care, maintenance and cleanliness of vehicles.

### **Out of Bounds Places**

74. (a) Girls Camp area will be out of bounds to all ranks other than those with specific duties in that area.
- (b) The Camp Commandant will notify in the camp orders other out-of-bounds areas is consultation with Station HQ Delhi Cantt. Untoward Incidents.

75. (a) Any untoward or abnormal incident affecting camp adm will be reported to the Camp Comdt immediately on occurrence either personally or by telephone who in turn will inform the following:-
- (i) DDG Lgs.
  - (ii) Addl DG (B)
  - (iii) DG NCC.
- (b) Inquiry investigation, if any, will be conducted immediately under orders of Addl DG (B).

## Security

76. General Deputy Camp Commandant will be security officer and fire fighting officer of the Camp. Personnel for guard and patrols, a necessary, will be provided under arrangements of the Dy DG,Trg. He will also arrange with police authorities for perimeter patrolling during the night, particularly of the open area to the WEST of the Camp. He will liaise with HQ Delhi Area Station HQ Cantt and tapioca authorities to tie up the details. Specimen of Camp Security Orders are at **Appendix G** for guidance.

77. All personnel participating in the RD Camp are forbidden to bring any costly/valuable articles with them to the camp. Lady Officers and girl cadets will not bring any gold ornaments/jewellery. If any so desire, they may bring a pair of bangles, ear tops and chain, provided they are not expensive and are taken care of by the owners.

78. Wagons Strict security measures for the safe custody of weapons their issue for parades/ rehearsals and return to kote, will be made. All rifles must be properly chained at night. One NCO will be detailed to be present in the kote both during the day and night in addition to the normal guard provided by the m/m price. Specimen kote Orders are at **Appendix G**. This duty roster will be published in the Camp Routine Orders by the Camp Comdt.

79. Civilian Employees Strict watch will be kept on the civilian employees of the Camp. Security passes duly affixed with latest passport size photograph will be issued to them by the Camp Comdt. Passes will be checked frequently under direct supervision of security officer. Camp Commandant will also arrange for issue of security passes to the contractors of furniture, Regimental Shops/ Dhaba and the employees of the contractors.

80. Admission into the Camp Area. Camp Commandant will issue necessary orders to ensure that no unauthorised person whether in uniform or civil clothes is permitted to enter the Camp Area. Gate sentries will be briefed accordingly.

81. Visiting Hours Relations of cadets will be allowed to visit the cadets between 1600 hrs and 1830 hrs daily. subject to the cadet not being on duty on that day. Availability of cadets can be ascertained from the Camp Adjutant one day in advance. A Visitors Room will be established in the Camp opposite the girls enclosure where the visitors can meet the cadets. Cadets will not be permitted to leave the Camp except when proceeding in organised parties ordered by the Camp Commandant. Out Passes will NOT be issued to cadets under any circumstances. This will be explained to all cadets selected for RD Camp prior to their move to Delhi. SOP on establishment of Reception Centre for visitors is at **Appendix H**.



### Fire Fighting-Officer, Equipment and Arrangements.

82. Dy Camp Commandant will act as the fire fighting officer for the Camp. NCC Dte Delhi will obtain adequate firefighting equipment or loan from Ordnance Depot Shakurbasti and make them available to the Camp Commandant by 15 Dec". Delhi Dte will also provide three tanks water vanvas ('S' type) capacity 1350 galons places. He will also detal a fire party from amongst advance party initially and later from contingents to deal with any unforeseen outbreak of fire. These parties will be trained and rehearsed by the Dy Camp Commandant and Contingent Commanders in the use of fire fighting equipment and to fight an actual outbreak of fire. The Camp Commandant will coordinate and seek assistance from the fire station located in the army RD Contingent Camp Area. The most common causes of outbreak of fire are as follows:-

- (a) Careless throwing of cigarette butts and 'bidi' ends.
- (b) Flying cinders from open fire used in the cookhouses or elsewhere.
- (c) Leakage from temporary or unauthorised electric connections and due to short circuiting.
- (d) Electric heaters and other unauthorised electrical gadgets.

83. While deciding the fire points and temporary lighting arrangements that may be made during the Camp, the above should be borne in mind.

84. A SOP on firefighting order is at **Appendix J**. This will be used as a guide by the firefighting officer (Dy Camp Comdt) while framing orders for the Camp.

### Civilian Camp Followers

85. Arrangements will be made to provide the required number of washermen, sweepers, cooks and water carriers as per scales given in Para 129 and 150 of the pamphlet 'Accounting instructions for NCC Camps'. Dte Gen (Lgs Dte) will arrange one JCO to advise on catering matters. The scales laid down in the Pamphlet are given below:-

(a) Mess Servants : Scale

(i) Cooks and water carriers etc. should be employed with due economy. The number of such personnel should be based on the following scale:-

Cooks	-	One per 45 Cadets.
Water carrier	-	One per 45 Cadets
Service boy	-	one per 45 Cadts.

(ii) The daily rates payable to them should be determined with due regard to the rates prevailing in the area. The civil authorities should be contacted for obtaining the requisite information. If the camps are held at military stations, the nerrick rates should be obtained from the Station authorities.

(b) Scale of Civilian Followers Dhobies, barbers and sweepers for Camp should be employed with due economy. The number of such personnel should be based on the following scale:-



- (i) Dhobies O A - One for 75 Cadets.
  - (ii) Barbers \_ T - One for 100 Cadets.
  - (iii) Sweepers One for 50 cadets (Where shallow and deep trench are used, the scale of sweepers will be 1 for 75 cadets).
- (c) Scale of Civilian Camp Followers, Prior to and and the Termination of the Camp.
- (i) Cooks In case cooks cannot be arranged through DST/Army HO, then these may be locally employed at the scale of four cooks for the first three days after the termination of the Camp and there after two cooks for the next ten days.
  - (ii) Sweepers 10 sweepers for 10 days prior to the commencement of the Camp and two sweepers for the first three days after the termination of the camp and one sweeper for the subsequent ten days.
- (d) Contracts may be concluded for cooking in the cadets and PI/Civ staff cook houses. This may also be done for officers' Messes and the scale of camp followers would be reduced accordingly.

### Local Purchase of Stores

86. Any stores purchased locally will require prior sanction of the Dy DG (P&F)/Addl DG/DG as the case may be. The purchase will be made in accordance with accepted procedure with due regard to economy. Camp Comdt will be given petty cash of Fls.5000/- which he may spend for urgent requirement preferably with concurrence of DDG concerned. However DDG/Camp Comdt will ensure that expenditure incurred is regularised within 48 hours. All stores thus purchased will be taken on charge. At the conclusion of the camp these will be surveyed .

87. On conclusion of the Camp all the RD stores and those purchased locally will be sun/eyed by a Board of Officers. Serviceable and repairable stores will be handed over to RD Camp stores for safe custody, care and preservation. Stores that can be repaired will be got repaired by ICRD Camp Stores under the orders of Dy DG (Lgs).

### Dispersal

88. All the Directorates providing contingents will purchase tickets for return journey and project their demand for return rail reservation to the railways at the starting station at the time of securing reservations for onward journey. After the tickets for return journey have been purchased and the demand for return rail reservation projected to the Railways, the Dte will fonivard details as per specimen given below. This report is required to reach the Dte Gen (Lgs Dte) by 10 Dec each year, indicating specific routes and trains by which reservations have been procured/projected :-

Date of return journey projected to the Name Railways	Train From No &	To	No of Seats Gents Ladies	Name of the Party Leader
---	-----------------	----	--------------------------	--------------------------

89. Dy DG NCC of States will ensure that the information contained in the Return is accurate. They will also pay particular attention to the routes/trains for lady officers and girl cadets and make

necessary arrangements for them in case they arrive at their destinations at night or have to halt temporary at night. The seating arrangements enroute will also have to be taken into consideration before deciding on the route to be taken particularly by lady officers and girl cadets.

90. Once the return journey tickets have been purchased and demand for return journey have been projected on the Railways at the starting stations, the Dtes will obtain copies of the communication (letter/telegram) sent by Railway authorities of the starting stations to the authorities of the railway stations from where the return journey is to be commenced.

91. They will keep Photostat copies of the aforesaid communication (letter/telegram from Railway authorities) and return tickets and send a responsible JCO from their Dte together with return journey tickets, above said letter/telegram (in original) and nominal roll of cadets (in quadruplicate) and requisite funds (if necessary) to Delhi for getting confirmation for the reservations as sought for. The JCOs thus deputed will report to Dte Gen (Lgs) latest by 20 Dec each year. All possible guidance/help will be given by Lgs Dte, in getting confirmation for the resonations.

92. All the Contingent Commanders should be advised by the respective Dtes that on reaching RD Camp they should send a confirmation report to Dte Gen (Lgs) by 10 Jan on the preformed as given in Para 89 above about return reservation secured from railways.

93. Once arrangements and rail reservation have been finalised, no charge will be accepted by the Dte Gen (Lgs). The final programme of dispersal will be issued to the Camp Commandant by this Dte Gen (Lgs) sufficiently in advance. The Camp Commandant will ensure that necessary intimation is passed on to the Contingent Commanders and the Directorate concerned. The Camp Comdt will be responsible for ensuring that the contingents arrive at Delhi/New Delhi Railway Stations sufficiently in advance keeping in view the time which may be required for booking and loading of the luggage before the time of departure of the train and that one officer from his staff accompanies each contingent to the railway station to supervise their entraining an orderly dispersal. He may set up staff consisting of one officer and few JCOs & NCOs to ensure the orderly dispersal of cadets. The Staff should function in the vicinity of MCO's office and ensure the proper marking of the compartments reserved for NCC Cadets. One officer from the Dte Gen (Lgs) will also be provided for liaison with the railway authorities and MCO.

94. The Contingent Commanders will intimate telegraphically the arrival of the contingents at the destination to the Dte Gen (Lgs Dte).

### **Issue of Medals and Certificates**

95. All Cadets attending the Camp will be awarded a certificate. Arrangements for issue of this will be made by Dte Gen NCC (Trg). The Nominal Roll of cadets selected forward of RD March Past will be sent by OI/C Competition to the secy RDCSC for making and endorsement to this effect on the certificate. Changes there after will be approved by the DDG (Trg).

96. (a) The responsibility for obtaining DG's approval on quantity required and sample of medals, prizes, trophies including individual prizes and DG's Cane of Honour is that of Trg Dte. Trg (A) will obtain the DG's approval, through Secretary RDC SC in the second week of August every year.

(b) The Trg Dte will inform Lgs Dte by 30 Aug every year the number of prizes/souvenirs/trophies, for procurement, including for foreign cadets and best cadet awards. Requirements of prizes for RD Banner competitions during centrally organised camps will also be included.

(c) Polishing of Trophies Lgs Dte will write to all NCC Dtes by 05 Aug to send RD Trophies (in proper packing) by 01 Sep for polishing and repairs if required.

97. To procure the above items viz medals, trophies, souvenirs, prizes including individual prizes and for polishing of trophies quotations from the dealers will be called for by Dte Gen (Adm Dte) during the month of Oct every year. Wide publicity through tender notice published in Newspapers will be given by the first week of Oct. The tender will be opened by a Board of Officers and on acceptance of tender, order will be placed on the successful tenderer to supply the requisite items.

98. Apart from the above Lgs Dte will place order, by 01 Sep, for six sandal/Rose wood batons, six ordinary wood practice batons for best cadets and one miniature RD Banner for Prize Distribution at PM's Rally (cost of batons to be eventually claimed from PM's Sectt).

99. The Trg Dte (Secy RDC) will obtain DG,s decision on policy concerning presentation items for visiting officer/Chief Guests at various functions and inform Lgs Dte for procurement action. ' PI Staff.

100. MS Dte will detail by 16 Aug every year, JCOs/NCOs (also Air and Naval equivalents) from different NCC. Directorates appointment wise for camp duties.

102. As very high standard of smartness and drill is required at the Camp, the JCOs (or equivalent) and NCOs detailed for training duties should be carefully selected by the NCC Dtes. Similarly, the JCOs (or equivalent) and NCOs selected for administrative duties must be experienced and well versed in their jobs. 1/3rd of the PI Staff will be selected from those who attended the last RD Camp.

### **PA Equipment for Internal Use**

103. Lgs Dte DGNCC will be responsible for the provision of PA equipment required for ceremonial parade, cultural shows and other functions. Dte and the Camp Signal Officer will arrange this in liasion with HQ Delhi Area. Dte Gen (Lgs Dte) will also be responsible for arrangement of PA equipment needed for internal use and for broadcasting in the RD Camp. The equipment should be in the Camp by 10 December.

104. For the above purpose Dte Gen (Lgs Dte) will ascertain availability of serviceable PA equipment for RD Camp by first week of Oct and take action to pursuer the same as per requirement.

105 Signal Personnel. The following signal personnel will be detailed by Dte Gen (MS Dte) for the Camp from Directorates for handling the PA equipment and maintaining the telephone exchange :-

- (a) JCOs.
- (b) Radio Mechanics
- (c) Operators.

### **Serviceability**

106. Lgs Dte/Camp Signal Officer should ensure that the PA equipment is in good serviceable condition in all respects.

### **Generator Sets**

107. Two Generator Sets with sufficient output for the Stage and Auditorium lights and other requirements of the Camp will be arranged from the local military units/Formation by Dte Gen (Lgs Dte) by 01 Jan and kept ready for main shows/use in case of electricity failure.

108. In order to procure the generator sets Dte Gen (Lgs Dte) will request Army HQ (MO Dte) for two generating sets of 63 KVA and 31 KVA for RDC by 05 Aug every year and pursue the same to procure the generators by 15 December.

### **Screening of Entertainment Films**

109. Dte Gen (P&F Dte) will arrange screening of entertainment film in the RD Camp.

### **Ammunition**

110. Lgs Dte is responsible for arrangement of ammunition and pyrotechnique for PM's Rally. Delhi Dte will forward the requirement of ammunition and pyrotechnique for PM's Rally to Lgs Dte by 15 July each year. Lgs Dte will forward the Demand by 10 Aug, for provisioning. Services of OC MARS, Delhi Area will be requested through HQ Delhi Area. Delhi Dte will maintain close liaison with Army HQ (OS-6) for collection of ammunition. Delhi Dte will also be responsible for storage of ammunition. Flags, Decorative Coloured Flags, Buntings and Saluting Dias for Ceremonial Functions.

111. Arrangements for the above will be made by Dte Gen (Lgs Dte) in consultation with Trg Dte.

112. Lgs Dte will approach E-in-C's Branch Army HQ by 15 Nov for issue of flag poles for the Rally, Poles with pullies for each Dte for Flag Area and pursue the matter for timely procurement.

113. Lgs Dte will arrange, by 30 Dec, car flags and stat plates for all Chief Guests and VIPs visits, as per their entitlement, for ceremonial parade. Service/National flag will also be arranged for additional flag pole on ceremonial review jeep. Decorating Saluting Basel Dias for PM's Rally.

114. The above responsibility for coordinating, control and supervision for the above work rests with DDG Lgs. Lgs Dte is also responsible for provision of required items, like furniture, matting, flag poles etc. The decoration of Dias including provision of flower pots shall be done by Lgs Dte by 18 Jan.

### **Preparation of Camp Inauguration Ground**

115. The responsibility for preparation of ground for Inauguration will be that of Camp Commandant RD Camp. In case of any difficulty he will refer the matter to Dy DG (Lgs) for guidance. Contracts of Cooks, Sweepers, Barmrs, Dhobi and Mochi.

116. DDG (Lgs) will be responsible for conclusion of contract for the above services. Requirement of six sweepers for PM's Rally will be catered for.

### **Sign Posting: Policy and List of Boards**

117. Lgs Dte will ascertain the requirement of above items from Camps Comdt. Dir (Coord) and CTO. Boards, paint, carpenter and painters will be arranged from local Army unit and will be paid honorarium from RDC Funds. Any item not available from the local Army units will be arranged from local market on payment out of RDC Funds.

### **117 Notice Boards**

- (a) Only brass notice boards will be displayed in front of the Adjutant's Office. All other boards will be displayed in the rear.
- (b) All notice boards will be bilingual, Hindi on top and English at the bottom. Where sufficient space is not available only Hindi boards will be displayed.

### **Daily Adm Conferences**

118. During HDC coordination conference will be held every day between 0800 hrs and 0830 hrs under Dy DG (Lgs). Important activities for the days as well as next will be coordinated during the conference. Change in timing of the conference, if any will be reflected in the Daily Camp Programme by secretary RDC SC.

### **Reception Arrangements**

119. (a) Layout Group /Advance Party.
- (i) Cooks and
  - (ii) Lgs Dte will initiate action regarding arrival of Advance parties at Delhi, by 03 Oct.
  - (iii) instructions regarding reception/adm of Camp Staff will be issued by Lgs Dte by 02 Dec.
  - (iv) Reception of Camp Staff will be arranged on 05 Dec or the date of arrival of the Group by Lgs Dte. Cook house for the Camp Staff will start functioning from 05 Dec or the date of arrival of the Group.
- (b) Contingents Camp Commandant will make arrangement for reception of the contingents as per Para 69 above.

### **Foreign Cadets-Adm**

120. Trg Dte is responsible for the issue of invitation and other arrangements for foreign cadets. Providing administrative over on arrival of the foreign cadets in the camp is the responsibility of Dy DG (Lgs). Important functions of Dy DG (Lgs)/Camp Commander are as under:-

**(a) Action to be Taken by Lgs Dte**

- (i) Arrange adequate transport for the origin cadets and Officer-in-Charge Foreign cadets.
- (ii) Arrange procurement of souvenirs as projected by Trg Dte.

**(b) Action to be taken by Dy DG (Lgs)/Camp Commandant**

- (i) Arrange living accommodation and furniture required for housing the foreign cadets.
- (ii) Detail lascars and service personnel to look after the messing.
- (iii) Assist the conducting officer in arranging messing.
- (iv) Provide transport to the conducting officer and cadets.
- (v) Provide sentry at the living accommodation for security.
- (vi) Oversee the reception and dispersal arrangements.

121. Trg Dte will finalise the programme for foreign cadets by 03 Oct every year and keep Lgs Dte informed of adm requirement from time to time.

122. LO Foreign Cadets/Lgs Dte will start work for preparation of living accommodation for foreign cadets from 01 Jan and ensure that the living accommodation and other adm arrangements concerning foreign cadets are ready before the cades start arriving.

**Adm of Animals & R&V Dets**

123. (a) Lgs Dte will ascertain requirement of furniture and other items for the R & V De/ Animals from the Trg dte and make arrangements for provisioning the same.
- (b) Camp Commandant will accommodate the PI Staff of R & V Dets with other PI Staff and attach them with PI Staff Mess.
- (c) Arrangements for keeping the horses/animal in a separate area in the Camp, earmarked for the animal, will be made by the Camp Comdt.
- (d) Dy DG (Lgs) will oversee the above arrangements.

**Cleaning and Preparation for NCC Horse Show**

124. Dte Gen (Lgs Dte) will take up a case with HQ Delhi Area in Oct allotment of suitable venue from 05 Jan to 20 Jan for Horse Riding Competition and NCC Horse Show.

125. On confirmation regarding availability of venue, Lgs Dte will liaise with MES authorities for repairs of bathrooms/latrines and other defects like electric fitting, water supply etc, by the last week of December.

126. Camp Commandant will ensure cleaning of the venue and getting it ready for riding competitions by 05 Jan. Dy DG (Lgs) will oversee these arrangements.

127. Dte Gen (Coord) is responsible for seating arrangements for Horse Show. Camp Comdt is responsible for making arrangements issuing instructions to the contractor for supply of furniture at venue.

## Camp Adm -General Policy

128. Dy DG (Lgs) and the Camp Comdt of the RDC under overall supervision of Addl DG (B) will exercise administrative control over all personnel located in the Camp. Salient features of Camp administration are as under :-

- (a) The camp will start on 05 Jan. The essential Camp Staff will report on 05 Dec.
- (b) All living accommodation will be ready/erected by 31 Dec. To achieve this all PI Staff detailed for the RDC (JCOs/NCOs) will report by 05 Dec.
- (c) One NCO from every contingent will report by 31 Dec so that he can take over charpoy, bulbs and such like items which are required by contingents (especially those arriving during night) immediately on arrival.
- (d) There will be a separate Officer in Charge Interior Economy who will also look after hygiene and sanitation of the Camp in general and cook houses, bathrooms, latrines and shopping complex in particular. He will be assisted by a JCO.
- (e) Lgs Dte will take up a case for attachment of five cooks from each of the five Commands of the Army from 08 Dec to 01 Feb and another five per Command from 25 Dec to 10 Feb. above cooks are not provided contracts for the cooks and helpers to different contractors (Preferably one per cook house) will be awarded on competitive rates.
- (f) To increase the food distribution points and to reduce the wastage additional utensils, if required will be purchased and paid out of Camp Fund.
- (g) Every cook house will be provided with a weighing machine. Provision will be made for locking devices for the electric bulbs.
- (h) All camp cutlery and un-expendable items of RD Camp will be suitably marked/engraved and taken on ledger charge.
- (k) There will be separate cooking for Officers' Mess.
- (l) As it is not possible to earmark separate transport for each Dte contingent, Camp MTO will provide vehicles to contingents on demand for visits to hospitals and other essential duties if ambulance is not available.
- (m) Menu for the Camp will be got approved from the DG, by Lgs Dte, by 15 December.
- (n) Liquor of any type, with the exception of medical comfort, will NOT be permitted inside the Camp and its consumption is strictly forbidden in the Camp.
- (o) A Board of Officers will be assembled in the second week of Dec each year for condemning items held in RDC Stores and for making purchases during the month of Dec.
- (p) Dry Rations and supplies for the duration of the RDC will be purchased and stocked by 05 Dec (before the arrival of Camp PI Staff) under arrangements of DDG (Lgs) who will obtain these from ASC Supplies or Authorised Govt. sources.



### **Sprinkling of Water**

129. Lgs Dte will make arrangements and write a letter, by 07 Dec to HQ Delhi Area with a copy to Engr Regt requesting them for sprinkling of water on the day of PM's Rally. NCC Dte Delhi will arrange for hiring of water bowsers for sprinkling of water. Demand of funds for the purpose will be projected to DDG (P&F) by 20 Sep.

### **Drinking Water**

130. SHO Delhi Cantt will be approached by Lgs Dte/Camp Comdt to test the water samples of the sources available & certify fit or otherwise for consumption by staff & cadets of the Camp. Such periodic checks will be arranged and super chlorination resorted to if advised by the medical auth/SHO with a view to prevent any occurrence of water borne diseases.

### **Duty Officer**

131. An Officer/JCO will be detailed as 'Duty Officer of the Day' during the period of RD Camp. Duty Officer's Duty Report Form is at **Appendix K**. Action on all points given out by the Duty Officer will be completed expeditiously. The form will be submitted for scrutiny to ADG (B) through Camp Comdt, DDG (Lgs) and Secy RDC.

### **Photo Shop**

132. A photo shop will be set up in the RD Camp. SOP on the Photo Shop is at **Appendix L**.

## **PART - II: FUNDS AND ACCOUNT**

### **Expenditure on Mechanical Transport, Accommodation, Electricity and Water**

133. MT Funds for the requirements of the camp will be obtained from Station Transport Officer Delhi Cantt and NCC Dtes .

134. Tents for Camp accommodation will be drawn from the Ordnance on loan. Electricity and water supply will be obtained from Garrison Engineer Delhi Cantt.

135. The expenditure on all these items is borne entirely by the Defence Services Estimates vide Government of India letter NO 4629/NCC/Coord (B)/2366-US/D(GS-III) dated 25 Sep. 62 .

136. Duty slips, car diaries, vehicle daily running account, log book for each vehicle and FOL ledger will be maintained for the duration of the Camp. Camp Commandant will get these documents audited by the LAO of Defence Accounts Department Delhi Cantt soon after the termination of the Camp.

137. **Funds.** SOP is attached as **Appendix M**.

(a) The Camp expenditure is shared by the Central Government and the State Governments on 50:50 basis. The expenditure in the first instance is met by the State Governments and debit in respect of 50% expenditure is raised by the States Accountant General against the Central Government.



(b) The entire Camp expenditure in the case of Junior Division cadets of Public Schools, Residential Schools, Merit Scholarship Schools and Central Schools is borne by the Ministry of Education, Government of India, for which funds are placed at the disposal of Controllers of Defence Accounts. The entire Camp expenditure in the case of Junior Division cadets of Military Schools is borne by the Defence Services. Estimates and funds are provided by the Controllers of Defence Accounts.

(c) The following items of expenditure which form part of the Camp expenditure are incurred at the unit level:-

(i) Cost of conveyance by road/rail to Delhi and back and journey daily allowance to and fro as laid down in Schedule II of NCC Act & Rules 1948 and as revised.

(ii) Pay of rank in the case of Senior/Division. NCC officers as per Schedule on NCC Rules 1948 and as revised.

(d) The following items of expenditure which are part of Camp expenditure are incurred at the Camp from out of the money remitted by the States for this purpose:-

(i) Cooks and

(i) Messing allowance at the current rates per Cadet NCC Officer per diem for 25 days.

(ii) Incidental expenditure at the current rates per Cadet per diem for 25 days.

(e) (i) Though the Camp expenditure is shared between the Centre and the States in the rates of 50:50 as mentioned in para 141 (a) above, the States will bear 100% of the expenditure initially and get the Centre's share reimbursed subsequently.

(ii) Dy DsG NCC will arrange for drawal of necessary funds from the State Govts/UTs on account of 100% expenditure in Camp for messing and incidental expenditure in respect of PTOs and Cadets and remit the same by Bank draft (not cheque) in favour of DGNCC payable at New Delhi. The Bank draft along with the details under various Heads should be sent in a Flegd cover addressed to DDG (P&F), Directorate General NCC, West Block No.4, R K Puram New Delhi - 110 066 latest by 10 Dec.

(f) AO RDC will open a Current Account in the name of the DGNCC with a Nationalised Bank and will deposit the bank drafts thus received. ,

(g) AO NCC RD Camp will issue necessary official receipts for the Bank Drafts received by him, to the NCC Dtes concerned direct and obtain their acknowledgements for his records.

(h) Dtes will be required to deposit in cash the actual amount at the same rate as RDC Camp for the number of extra days the Officers/PI Staff/Cadets are required to dine in the Camp.

138. Necessary funds for the above items will be drawn and disbursed by the unit. It will be ensured by each Dy DG NCC that the participating officers and cadets are given the necessary funds for the journey to Delhi and back. All arrangements for the journey to Delhi including rail reservation etc are to be made by the NCC Dtes concerned under their own arrangements.

## Maintenance of Accounts

139. Dy DG (P&F) is ultimately responsible for the proper custody of cash, cheques and for proper maintenance of the Camp Accounts in accordance with the Pamphlet "Accounting instructions for NCC Camps and any specific subsidiary instructions issued by the DG. He will be assisted by the Accounts Officer (HDC). All documents required for efficient functioning of the Camp and for audit vide Para 231 of Accounting Instructions for NCC Camps" will be maintained under the supervision of the Dy DG (P&F).

140. On termination of the Camp, all pending bills will be promptly settled and the accounts closed. The proportionate unspent balance will be refunded through Bank Draft to the respective NCC Directorate concerned. citing reference to the covering letter under which the bank draft was sent to Accounts Officer (B&F), Dte Gen NCC, New Delhi, to enable them to link the correspondence and credit the amount to the State Govts/UT Adms/ CDA from whom the advance was drawn and the cash book for the Camp closed to NIL balance.

141. As per Controller and Auditor General letter No. 1684/Adm 1/ 665-1 dated 12 Jul 67, audit of the NCC Camp account is the responsibility of the Director of Audit, Central Revenues, New Delhi. The Directorate General NCC (Pers (B&F) will arrange with Director of Audit, Central Revenues, New Delhi to depute his Audit party to the Camp to audit the camp accounts immediately after the closing of the Camp. The Audit party will be asked to render certificate of audit indicating the share of each participating NCC Unit.

142. Dy DG (P&F) will render a balance adjustment account to each NCC Dte to enable them to submit the accounts to the AG of State/UT or the CDA as the case may be.

143. (a) Regimental Accounts Separate Regimental Accounts for the Camp Officers Mess, Canteen etc will be maintained by the Camp Comdt for the duration of the Camp according to the normal rules. These accounts will be closed on the termination of the Camp and audited by a Regimental Audit Board.

(b) Other Public Funds, if any; Sanctioned by the Central Government for the NCC RD Camp on Adhoc basis. Separate accounts will be maintained by the AO (RDC) for such funds and the same will not be mixed with other Camp funds received from the participating NCC Dtes on account of States share of Camp expenses. Such amounts from Central Govt will be drawn from the CDA (HO) G Block, New Delhi and the final accounts will be submitted to that office for audit and adjustment viz -a-vis Govt sanction.

## Residual Work

144. All accounts and documents of the Camp will, on its termination, will be handed over to AO (RDC) by the Camp comdt for safe custody and production of the same to audit party.

145. One AO with at least three clerks will be posted to QM side. The AO will be provided daily parade statement by the camp office. Camp office will clearly indicate the strength of AE/RE & Meat Eater/Non ME each day on the parade statement to enable the AO posted in QM office to check the correctness of issues of dry/fresh rations to the feeding strength of the camp.

## HYGIENE AND SANITATION

### Living Area

1. Living area will always be kept clean and tidy. Stray dogs and animals will not be permitted in the living area. There should be proper drainage and water should not be allowed to stagnate either in low lying area or pits or in empty tins or containers. Civilians employed must be medically fit, inoculated and vaccinated. Sale of eatables, except through the authorised Wet Canteen/ Flegtl Shops, is not permitted. Indiscriminate spitting and blowing of nose will be discouraged.

### Barracks & Tents

2. Living accommodation barracks should be kept neat and tidy. There should be no over crowding and the accommodation must be well ventilated and lighted.

3. In the case of barracks, doors, windows and ventilators should be kept open. In the case of tents, the side walls must be rolled neatly and the ventilators kept open.

4. Personnel kit will be exposed to sun and air at least once a week. Towels must be exposed to sun and air daily.

5. Refuse bins must be provided for each group of tents/barracks to hold dry refuse for final disposal by the Cantonment Board.

### Water Supply

6. Water for drinking and cooking will be obtained from approved sources only. Unchlorinated water will not be used.

7. Receptacles for storing water such as barrels, "gharras" and buckets will be cleaned daily and kept covered. Suitable aluminum dippers with handles will be provided and the dippers will be kept immersed in the receptacles. Drinking water will be provided near cook houses, dining halls and training area, preferably in covered plastic buckets fitted with taps. It will be ensured that no wastage of water occurs from leaking/missing taps in case of piped water supply.

### Bath Rooms

8. Bath rooms will be cleaned daily. During winter months, hot bath should be arranged at least twice a week.

9. Indiscriminate bathing in unauthorised places or streams is prohibited.

10. Bath rooms must have a cover on top and arrangement for an adjoining room for changing clothes must be made.

11. The floor of the bath room must be kept clean at all times.

### Dining Halls

12. Dining halls must be fly proof and made to look as attractive as possible. Improvised proofing may be resorted to by using camouflage nets. Antifly measures, as applicable to cook house, must be observed.

13. Dining tables will not be painted. These will be scrubbed with brush, washing soda and hot water at least twice a week.
14. Suitable containers for bones and inedibles will be provided on the tables.
15. If the floor is not pucca, it should be 'lipoid' regularly.
16. Refuse would be disposed of in the receptacles to be kept near the kitchen where arrangements for washing hands and plates would also be made.

### **Officers Mess**

17. The rules applicable to cook houses and dining halls apply equally to the Officers Mess. Rules for hygiene for the cook house, nominal rolls of men working in the Officers Mess showing dates of TAB inoculation, vaccination and medical examination will be hung at a suitable place in each Mess.

### **Rations**

18. Fresh rations will be regularly inspected for quality and quantity. A responsible person who is conversant with the ration scales and specifications will be detailed to draw the rations.
19. Suitable containers for protecting the rations from dust, flies and rats will be provided. Flyproof container lined with galvanised iron, sheet will be used for collection of meat.
20. Rations will be stored in clean, well ventilated, flyproof room/tent. Rat traps will be used to exterminate any intruders.
21. Rations will be turned over regularly. It will be ensured that canned food stuff which has overshoot the warranty period is not issued for consumption. Similarly, stale or fungus infected articles of food will not be issued.
22. Fruits and leaves of vegetables which are eaten raw and unpeeled will be soaked in solution of bleaching powder (one tea spoon to a gallon of water) for 1/2 an hour and then washed with clean water before they are consumed. .

### **Shopping Complex**

23. All employees of Canteen & other shops selling eatables will ensure that they are not suffering from any contagious disease. Nominal roll of the employees showing date of TAB inoculation, vaccination and medical examination will be displayed in the shops. The shops will be inspected daily by the Camp Comdt/Dy Camp Comdt Officer I/C Shopping Complex.
24. Canteen will be kept scrupulously clean at all times. The orders for cookhouses and dining halls apply equally to the Canteen cookhouses and the Canteen hall. Potable drinking water will be made available. Cups/tumblers will be sterilized with steam. Ample supply of clean dusters will be provided.
25. Food/eats will be kept in flyproof cupboard and will be served using forks/tongs, untouched by hand.
26. Aerated water will be obtained from authorised sources only. Milk will always be boiled before use. Vessels for storage of milk and curd will have flyproof covers.

27. All those who handle food or other eatables will have a high standard of personal hygiene. They will wear clean white clothing and headdress.
28. Facilities for washing hands, i.e. water, soap, nail brush and clean towel will be available at all times.
29. Refuse bins with covers should be provided for collection of refuse. Disposal of sewage water should be done as for cookhouses.

### **Barber's Shop**

30. Regular inspection of Barber's Shop will be carried out in order to ensure high standard of hygiene and sanitation.
31. A nominal roll of barbers with their dates of medical examination, inoculation and vaccination will be put up in the shop.
32. Barbers will wear clean clothing with aprons while working.
33. Clean towels and sheets and adequate washing facilities will be provided.
34. A tin or a bucket with proper lid will be provided to hold used cotton and cut hair.
35. Barbers will be instructed not to shave or cut hair of any one suffering from skin disease. Such cases will be referred to Camp Medical Officer for advice. All cuts, however, minor they may be, will be swabbed with tincture iodine/Cetavalon to be obtained from MI Room.
36. Barbers instruments will be treated in the following manner:
  - (a) Combs, razors, scissors and nail clippers will be kept immersed in 2.5% cresole, dettol or chlorosol, during working hours. They will be washed in clean water before use.
  - (b) Shaving brushes will be washed in 1% soda ash and cleaned in running water before taking into use.

### **Personal Hygiene**

37. General Personal hygiene deals with such precautions which the individual himself observes for maintenance and promotion of his own health and prevention of any disease. Observance of the principles of personal hygiene should become part of cadets'/soldiers' normal habit.
38. Personal Cleanliness Personal cleanliness of the body is of great importance. Following points are of special importance:-
  - (a) Hands These must be washed regularly before and after eating, and after visiting the toilet. Nails should be kept short and clean.
  - (b) Bating Daily bath is the ideal. At least two baths per week during winter months are minimum required to keep the body clean. Arrangements for hot water during winter must be made.
  - (c) Care of Feet Boots/shoes and socks should be of the correct size offering comfort when worn. Socks should be washed daily after use. After the day's work feet should be washed particularly the area between the toes. The toe nails should be kept short and

clean. To avoid in growing of nails, these should be cut straight and not in a curved manner adopted for finger nails.

- (d) Clothing : Clothing must not be tight fitting and must be laundered at least twice a week. Under clothing should be washed daily and 'bhattied' at periodical intervals. Communal use of clothing will be avoided.

### Food and Drinks

39. During meals, food must be well masticated, eaten slowly and serious thinking avoided. Food and drinks from dirty, unauthorised sources are to be avoided.

### Sleep and Rest

40. Adequate and regular sleep is indispensable for health. About eight hours sleep daily is necessary. Apart from sleep, rest and relaxation during regularly laid down periods must be observed.

### Mental Health

41. Mental health is as important as physical health. Remember the dictum "A sound mind in a sound body".

42. Mental reactions to external stimuli are dependent to a great extent on the state of physical health and social environments. Maintenance of good general health by proper food, exercise, rest sleep and agreeable social environments is essential for good mental health.

43. Stress and strain during work and training should be within the limits of the endurance and capacity. Each Cadet/soldier should learn for himself the best means to avoid emotional stress, and anxiety.

44. Excessive fatigue especially mental fatigue should be avoided. Physical activity should be balanced with mental activity. Variety is the keynote of interest and interest recreates energy. Proper man management, inculcation of good inter-personal relationship, creation of mutual trust and confidence and other morale building activities should be emphasised.

45. Following protective habits of mind should be kept in mind for promotion of mental health

- (a) Combs
- (a) To get enjoyment after one's routine work.
- (b) To have satisfaction out of moderation rather than extreme.
- (c) Enjoyment out of music, art and literature.
- (d) Not craving for sympathy, not demanding appreciation, not magnifying own difficulties.
- (e) Quick to admit one's own mistakes and not put blame on others.
- (f) Faith in God as the supreme Power, irrespective of one's own caste or creed.
- (g) Sense of achievement, irrespective of the results achieved, **DO YOUR BEST: DO NOT WORRY ABOUT THE RESULT.** This will enable one to gain great mental strength against adversities.

**SPECIMEN DAILY MESSING EXPENDITURE STATEMENT**

Feeding strength as per daily Camp Routine Order No ..... ..

	<b>VEG</b>	<b>NON VEG</b>
Cadets		
Service Offrs, incl WTLO		
ANO		
PI Staff		
Civilians		
<b>Total</b>		

<b>Ser No</b>	<b>Item</b>	<b>Qty Issued</b>	<b>Rate per unit</b>	<b>Cost</b>	<b>Remarks</b>
<b>Total</b>					

Expenditure on misc items connected with messing.

Pay of cooks, service/water carriers .....

Expenditure on transportation of dry and fresh rations.....

**GRAND TOTAL**

Feeding strength for the day .....

Expenditure per head.....

Total monetary entitlement for the day .....

Total expenditure for the day .....

Saving/Excess for the day .....

Saving/Excess for the previous day (s)..... ..

Progressive Saving/Excess .....

Signature	Camp Comdt.	Staff	AO (M)	
Signature	Purchase Committee presiding Officer	NCC	Cadet Offr	
Signature	Messing Committee	Presiding Officer	NCC	Cadet Officer

**MENU**

Bed Tea .....

Breakfast.....

Lunch .....

Evening Tea .....

Dinner .....



## SOP: RUNNING OF COOK HOUSES

### 1. Cook House

- (a) Cook Houses must be fly proof, if necessary, by improvisation. Camouflage nets if available can be used otherwise three mosquito nets will suffice to cover the cooked food and cut vegetables. Mosquito nets can be obtained by units from Salvage Depot.
- (b) DDT 5% solution suspension will be sprayed as a residual insecticide one a week during fly season. Pyrethrm 0.1% in kerosene oil will sprayed for direct killing of flies as and when required. Fly flaps and serviceable hand sprayer will always be available in the cook Houses.
- (c) 'Choolas' will be built one foot above the ground level to avoid dust getting into the food. Chimneys will be improvised to avoid smoke nuisance in the Cook Houses.
- (d) Proper platforms will be built for washing utensils and keeping water containers.
- (e) Sullage water should pass through grease traps if disposal is done through soakage pits.
- (f) Floor of the cook houses will be 'Lipaied' regularly and kept scrupulously clean.

### Cooks

- (a) Cooks should be contracted well in advance by QM and he must tell them that they will be employed only if they produce medical certificate with dates of vaccination and TAB inoculation. Their nominal roll showing dates of vaccination and inoculation will be exhibited in the Cook House.
- (b) All cooks and other food handlers will be medically examined prior to employment i.e. before the commencement of the camp. Cook and servers normally contact the QM about a fortnight before the commencement of the camp and they are also employed as labourers for setting up the Camp.
- (c) Persons who have suffered from typhoid group of fever or infective hepatitis in the last one year or are suffering from dysentery, diarrhea, sore throat, common cold, boils and wounds on fingers should not be employed in the Cook House or food handling duties.
- (d) Cooks and other food handles will invariably wash their hands with soap and water prior to commencement of work and after every visit to the latrine/urinal. Adequate hand washing facility, e.g. water, soap, nail brush and clean towels will be made available. A water drum with tap will be provided for this purpose.
- (e) Cooks will always maintain a good standard of personal hygiene. They will be cleanly dressed and provided two sets of special cooks clothing each. They will wear white caps/ turban while working.
- (f) Cooks will not be permitted to sleep or keep their private belonging in the Cook Houses. Smoking in the Cook House will be forbidden.

### Utensils

- (a) All cooking utensils will be scrupulously cleaned after each meal with ash and water. These will 'muttied' outside to avoid accumulation of soot. Brass utensils will be tinned.
- (b) Preparation table to cut vegetable will be provided in the Cook House. This table will have marble/metal sheet top.
- (c) Massala containers will be regularly cleaned and neatly arranged.
- (d) Tables and cutting boards in the Cook Houses will be cleaned by scrubbing with hot water containing soda every day.



- (e) Milk will be boiled immediately on receipt. Utensils for milk will be cleaned with brush, soap and hot water.
- (f) Sufficient supply of clean dusters for cleaning and drying of cooking utensils and dishes will be ensured. Such dusters will be washed with soap, washing soda and water after the last meal every day.

### **Food**

- (a) All vegetables will be washed in water mixed with bleaching powder at the one tea spoon of bleaching powder in four liters of water. After that the vegetables will be washed in clean water and then cut or peeled.
- (b) Cooked food will be kept covered at all times. Chapatis will be kept in the chapati baskets provided with a detachable cloth lining which will be washed regularly; Cooked rice will be kept in degchies or other suitable metal containers
- (c) No left over food will be served during the next meal as the germs of food poisoning often multiply during storage of such food.
- (d) Left over food and other waste and refuse from the cook house will be deposited in the refuse bins with cover. A refuse bin for this purpose will be placed on a raised platform near the cook House.
- (e) Chapatis will be rolled on clean wooden boards.

### **Layout of Cook Houses**

- (a) Cover on top should be provided with tarpaulin which should slope one foot to every four feet on the sides.
- (b) Side walls should be of tin or asbestos sheets to avoid fire risk. 'Canvas' would only be used if the above sheets are not available. Sufficient quantity of loose earth for fire fighting will be kept near the Cook Houses.
- (c) In case of permanent or regular camp sites such as FIDC the Cook House floor should be cemented and pucca cooking range constructed.
- (d) Two "choolas" for burning of coal and one for wood to prepare chapatis be provided. Improvised chimneys should be built to avoid smoke nuisance.
- (e) Coal, instead of fire wood, will be used in the cooking range as it will more economical
- (f) Dry, instead of wet wood, be used. Cost of dry wood is more but in fact it is economical than the cheaper wet wood. It also reduces smoke and results in better preparation of food.
- (g) Cook house should be so sited that it does not get flooded with rain water.
- (h) For economical use of fire-wood, the feeding strength of the Cook House should not be less than 300.
- (j) Cook houses should be sited at least 50 yards away from the living tents and should not fall on the route to bath room and atrines.

### **Storing of Water**

- (a) Two metal/plastic containers, (capacity 100 litres each) with taps and covered top will be provided.
- (b) Water should be sifted through the cloth into the container. After filling, lid should be closed and locked.

- (c) Similarly 200 litres more of water will be stored in the Cook House for cooking purposes.
- (d) Two drums of water with taps will be placed on the washing platforms for cleaning utensils.

#### **Scales of Cooks, Servers and Water Carriers.**

- (a) One cook per 60 feeding strength may be employed. That will give five cooks per Cook House of 300 feeding strength. One cook is employed for preparing vegetables, one for dal, one for rice and one to make chapatis. The fifth is the head Cook who supervises and helps others whenever necessary. .
- (b) Three helpers are required for making chapatis, two to roll and one to bake on charcoal. At least two more are required for cutting and filling of vegetables and helping other cooks. Scales of servers should also be five per cook house i.e. one per 60 feeding strength.
- (c) When the tap water is available in the Cook House and water can be filled directly into the containers through flexible pipe, the number of water carriers can be reduced to one per 100 i.e. three in a cook house. One person is required permanently in the QM Stores for sorting out rations and carrying them to cook houses. The other two re used for cleaning the utensils and helping in food preparation.

#### **8. Preparation of Food**

- (a) Casual labour will be employed by QM to clean Dal and Rice.
- (b) Rice, if it has lot of husk on it, will be sent to the mill for polishing. .
- (c) Vegetables once cut will not be washed with bleaching powder as the bleaching powder will destroy all the food value in the vegetables.
- (d) Peelings and discarded leaves will be boiled, and their soup used for cooking the vegetable to increase its food value.
- (e) Brinjals and potatoes will be cut immediately before cooking. Otherwise their colour changes.
- (f) Rice will be cooked in minimum of water. Rice water, if any left during cooking will be used in vegetable curries. This increases its food value.

**REQUISITION OF TRANSPORT**  
(To be submitted 48 hours in advance)

1. Name of Officer requiring Tpt :
2. Type of Vehicle required :
3. Date & Place required :
4. Specified nature of duty to :  
be performed and destination
5. Approx. miles/Kms proposed :  
to run both ways.
6. Duration of duty :
7. Telephone number on which the :  
Officer can be contacted.

Signature of Officer  
Rank :  
Designation :

Countersigned

Date :  
Dy DG

---

**APPROVED/NOT APPROVED**  
**DDG Logs**

Vehicle detailed

BA No \_\_\_\_\_ Time \_\_\_\_\_

Driver's Name \_\_\_\_\_ MTO RDC \_\_\_\_\_

(To be filled in by the indenting Officer on completion of duty)

1. Km Run \_\_\_\_\_
2. Duration (Time consumed) \_\_\_\_\_
3. Place visited \_\_\_\_\_
4. Any remark \_\_\_\_\_

Signature of the  
indenting Officer

## STANDING OPERATING PROCEDURE FOR CSD CANTEEN FOR RD CAMP

### General

1. CSD Canteen extension counter will be opened in RD Camp area to facilitate officers, PI Staff and Cadets attending RD Camp to obtain their day-to-day requirements of Canteen items.  
Aim.
2. The Aim of this SOP is to lay down the standard operating procedure for the smooth functioning of CSD at RD Camp. Getting up a CSD Canteen
3. The Camp Comdt RDC will be responsible to provide suitable accommodation in the RDC Shopping Complex in one Store Tent to house CSD Extension Counter and Non-CSD Counter. Adequate lighting arrangements will also be made by the Camp Comdt for sale of items.
4. DGNCC canteen officer will function as Canteen officer of CSD RD Camp in addition to his own duties, under the direction of Chairman, CSD, DGNCC. Canteen Officer will be responsible for overall running of the canteen. He will ensure that the canteen is opened at the time specified. instructions laid down in the succeeding paras are strictly followed :-
  - (a) He will oversee the functioning of the staff detailed to run it.
  - (b) He will assess the bulk requirements of the canteen and obtain stores from the Dte Gen Canteen.
  - (c) He will carry out check of daily sales summary every day to see that the sales are being properly regulated and accounted for.
  - (d) He will ensure that proper accounting procedure is followed.
  - (e) He will be personally responsible to the Chairman, CSD, DGNCC and will apprise him of any difficulty being experienced in efficient functioning of the canteen and implementing any order given to him from time to time.

### Staff

5. The Extension Counter of C9D RD Camp will be managed by the Canteen Manager of DGNCC under the directions of Canteen Officer CSD, DGNCC. The CSD Extension Counter and non-CSD counter will have the following staff:-

#### CSD Canteen

- |                            |   |
|----------------------------|---|
| (a) Store Keeper           | - one NCO (DGNCC CSD)                                 |
| (b) Delivery Counter       | - 4 NCOs To be attached under                         |
| (c) Sales men (Bill issue) | - 4 NCOs orders of DDG Adm from Camp.                 |
| (d) Cashier                | - Civilian staff member of<br>CSD DG NCC (Sale Asst). |
| (e) Account Assistant      | - Civilian staff member of                            |

CSD DGNCC (Sale Asst).

- (f) Assistant» manager - JCO to be attache under order of DDG Adm from Camp.

### **Non-CSD Canteen**

- (g) JCO Non-CSD Canteen - 1 To be attached under  
 (h) NCOs Non-CSD Canteen - 2 orders of DDG Adm from Camp.

6. The Staff for the CSD Canteen will work in two shifts a under:-

- (a) Shift I : 0800 hrs to 1600 hrs  
 (b) Shift II : 1400 hrs to 2200 hrs

### **Timings**

7. CSD will open to 1000 hrs evry day and will remain open till 2100 hrs. The following timings will be adhered to:-

- (a) Authorised persons - 1000 hrs to 1400 hrs.  
 (b) Officers in person - 1000 hrs to 2100 hrs. 1  
 (c) Cadets - 1400 hrs to 2100 hrs.

8. Morning hours from 0800 hrs to 1000 hrs and evening hours from 2100 hrs to 2200 hrs will be utilised by the Canteen Staff for checking, accounting, replenishment of stores and maintenance of accounts. During the sales timings for the cadets, except for officers in person, no other customers will be entertained by the Canteen Staff.

### **Sales Procedure**

9. In the Canteen, there will be two bill issue counters managed by two NCOs. One will be for he Gents/Boys and another one for the Ladies/Girls. Small sign boards with Ladies/Girls cades and Gentsl Boys cadets only written onit will be displayed prominently. Gentsl Boys and Ladies/ Girls cadets can get the bills from respective counters. Similarly there will be two delivery counters for Gents/Boys and Ladies/Girls separately managed by two NCOs.

10. There will be one cash receipt counter which will be managed by staff member of the CSD.

11. One NCO attached with DGNCC will be detailed as a storekeeper t ensure that sores are available at all times. A staff member of CSD will be deailed as account assistant 'to prepare daily sales summaries.

12. Sales will be on cash only. Credit system will not be permitted. The sale money will be deposited with the Camp Comdt at the close of the canteen for safe custody and same will be deposited with the ban/k extension counter by 1200 hrs every day. Every day Canteen Manager accompanied by escort to be found from the Canteen staff will proceed to RK Puram of depositing the cash and replenishment of stores in the Ferry Senice being operated between RDC and FIK Puram.

13. Daily sales summaries will be prepared by 1000 hrs the next day by the sale assistant and put to Canteen Officer for counter signatures. The CSD will only cater to Groceries and General Stores. Liquor will not be catered for and will not be sold from extension counter CSD RD Camp. A suggestion book will be kept by Canteen Manager for further improvement of CSD and this will be shown daily to OIC Canteen, Chairman CSD DGNCC.

### **Advance Preparations**

14. Daily utility items will be the main requirement of the cadets. Generally stores as indicated in the attached Annexure will be demanded from CSD Stores beginning from Sept onwards.

15. Adm Directorate DG NCC will cater to the requirement of following furniture:-

(a)	Almirah large steel with lock and key	- 1
(b)	Chairs steel	- 4
(c)	Sales Counter size 10' X 3-1/2' X 2-1/2'	- 2
(d)	Steel Rack 7' X 3' X 13"	- 8
(e)	Steel Chairs high	- 2
(f)	Office table	- 2

### **Non-CSD Stores**

16. CSD caters for all types of stores for the consumers. However, there may be occasions when some items may not be available immediately with the Depot. To overcome the problem, Canteen Extension counter will have a separate counter for non-CSD store which will be demanded, stored, sold and accounted separately. For this purpose, a JCO and two NCOs who will be attached with Canteen will function under Canteen Officer and will be responsible for smooth sale of Non-CSD stores and its accounting.

17. For the above purpose, a separate account will be opened in the bank and will be maintained by Canteen accounts assistant. A sum of rupees ten thousand will be drawn as loan from DG NCC Ftglt fund and profits on account of Non-CSD Canteen will also go to Regtl fund.

18. Separate bills will be issued for non-CSD items. The NCOs attached will function as Cashier/billing/sales incharge and will deposit the daily sales with JCO IC non-CSD who in turn will deposit the same in the bank under orders of Canteen Officer.

19. Daily accounts will be prepared as is done in case of Regtl accounts and orders on Accounts and Prevention of fraud will be completed with.

20. The Store Keeper will return unsold stores to the CSD Dte Gen NCC at the end of the Camp. Clearance will be obtained from the Chairman, CSD Canteen before the individuals responsible to run the camp canteen return to parent unit. Camp Comdt will issue movement order after the clearance has been obtained.

## SOP - SHOPPING COMPLEX FOR REPUBLIC DAY CAMP

### General

1. The Shopping Complex for RDC is set up normally from 01 Jan to 30 Jan in the area adjacent to the Reception Room and opposite to the Girls living Area.

### Aim

2. The aim of the Shopping Complex is to provide various hygienically prepared eatables to cadets at cheap rates.

3. The Shopping Complex will function under the overall responsibility of the DDG (P&F). The following will constitute the Shopping Complex Cell :-

- |     |                                |                               |
|-----|--------------------------------|-------------------------------|
| (a) | OIC Shopping Complex           | - DIR (PERS)                  |
| (b) | Asstt Shopping Complex         | - DD (PERS)                   |
| (c) | JCO in charge Shopping Complex | - 2 JCOs detailed by Adm Dte. |
| (d) | NCO in charge Shopping complex | - 1 NCO detailed by Adm Dte.  |
| (e) | Officer in charge bills        | - ACSO (P&F Coord)            |

### Duties of the Shopping Complex Officials

4. (a) OIC Shopping Complex Officials
- (i) He will interact with the contractors to ensure efficient function of the Shopping Complex.
  - (ii) In case of a demand for any item from cadets or request for inclusion of any item by a contractor, he will recommend and obtain approval for the same from DDG (P&F) on file.
  - (iii) He will ensure that the items provided in the Shopping Complex are hygienically prepared.
  - (iv) He will deal with all suggestions from cadets and will take approval of DDG (P&F), wherever required.
  - (v) He will warn the contractors in writing in case of any infringement of the contract.
- (b) Asstt Shopping Complex.
- (i) He will assist the OIC shopping Complex and will carry out his duties in his absence.
  - (ii) He will help to solve the problems of the contractors.
  - (iii) Keep a check on the quality and quantity of items provided by the contractors.
- (c) JCO in charge Shopping Complex : One JCO out of the detailed will always be present in the Shopping Complex. Their duty hours will be fixed accordingly. Their duties will be as follows:-
- (i) He will supervise the pitching of Shamiyana and other arrangements for the Shopping Complex.
  - (ii) He will ensure that the cadets observe discipline in the Shopping Complex area.
  - (iii) Ensure that contractors observe opening and closing timings of the Shopping Complex i.e. 0900 hrs to 2200 hrs.

- (iv) Ensure that only those items are sold in the complex which are approved and at the rates laid down.
  - (v) Ensure that price lists are properly displayed. ~
  - (vi) Ensure proper hygiene in the cooking area.
  - (vii) Ensure that the area is and around the Shopping Complex is kept clean.
  - (viii) Carry out a random check of weight of selected items and bring any discrepancies to the notice of OIC Shopping Complex.
  - (ix) Inform the OIC Shopping Complex daily of any problems encountered during the period of duty.
- (d) NCO in charge Shopping Complex
- (i) He will supervise cleaning of Shopping Complex Area prior to its opening and after closing down everyday.
  - (ii) He will ensure that discipline is maintained in the living area complex for the contractor's staff.
  - (iii) He will ensure that cadets maintain discipline in the Shopping Complex.
  - (iv) He will bring any problems encountered to the notice of the JCO in charge Shopping Complex.
- (e) Officer in charge Bills
- (i) Expeditiously process all bills received from the contractors on account of items provided towards VIP refreshments.
  - (ii) Obtain decision on file on matter related to inclusion exclusion of certain items and fixing of their rates.
  - (iii) Ensure that the price list of various items is displayed by the contractors and is as per the rates and weight fixed in the contract.

### **Contract for Shopping complex**

5. The action for giving contract for the Shopping Complex will be initiated in the month of August. Two tender notices will be published in two English and Hindi newspapers, one for the furniture item, Shamiana, Chairs, Tables etc and the other for the various stalls required. In case of the latter the interested parties are provided a tender form listing out the various items required for the stalls and the terms and conditions of the contract. A Board of Officers is to assemble thereafter to select the contractors based on the quotations provided and capabilities to perform the task. The contracts should be finalised by 25 Oct to enable the contractors to plan in advance.

### **Security Passes**

6. The contractors will be provided with Security forms required to be filled, by 10 Dec. The security forms duly filled will be forwarded to the Camp Adjutant by 20 Dec so that all persons required to work in the Shopping Complex can be provided the security passes by 25 Dec.

### **Administration**

7. The Adm Dte will be responsible to provide the following :-
- (a) Provision of electricity connection to the Shopping Complex and lighting arrangements outside Shopping Complex.
  - (b) Provision of tentage for contractors staff living area and stores.
  - (c) Removal of garbage and provision of conservancy staff for cleaning the area around the Shopping complex.
  - (d) Provision of water.



**NCC REPUBLIC DAY CONTINGENT CAMP DELHI CANTT  
KOTE ORDERS**

**General**

1. Arms and ammunition brought by the Contingents will be stored in the two kotes. Each Kote shall have only one entrance.
2. The Kote will be guarded by civil police all the time. This guard will ensure that no unauthorised persons enter Kotes. They will be supervised by one regular Armed Forces NCO per Kote who will assume overall responsibility for the same in the Kote and will sleep in the Kote at night.
3. All rifles will be secured to the rack by a chain put through the trigger guards and padlocked.
4. Live ammunition and empties are to be stored in separate boxes which are to be separately marked.
5. Kotes are not to be opened between Retreat and Reveille except with the permission of the Camp Commandant. On such occasions the Orderly Officer will invariably be present.
6. Separate registers will be maintained for arms and ammunition.

**Checking**

7. The orderly JCO of the day will carry out a physical check of all arms and ammunition in all the Kotes at Retreat and sign in the kote registers stating the actual state of arms and ammunition in the kote. In addition the Orderly Officer will also carry out a physical check during his tour and record the results.
8. The arms will not be changed over from one kote to other.
9. A list of arms held will be displayed in each kote.

**Opening and Closing of Kotes**

10. The Kotes will remain open only between Reveille to Retreat and will not be opened between Retreat and Reveille without the permission of the Camp Commandant.
11. At the time of opening the kotes, JCO in-charge of respective Kotes will open them assisted by the Kote NCOs.
12. They will ensure that the Kotes are clean and all arms are present in the Kotes, which will open at the specified time only.
13. At the time of closing, the Kote JCO will ensure that all arms kept in the kotes are properly cleaned and secured with chain and locked properly. Each Contingent Commander/JCO in-charge contingent will ensure that their Directorate arms are secured by 'chain properly. They will also seal the locks and retain the key. The duplicate key will be deposited with the Dy Camp Comdt.
14. The kote JCOs will ensure that the chains are properly sealed before the kote is closed and sealed.

**Documents.**

15. The following documents will be maintained by the kote JCOs:
  - (a) Kote Register.
  - (b) Kote handing/taking over Register.
  - (c) Daily Issue Register.
16. Kote handing/taking over register will be properly maintained by the JCOs for each kote respectively.

### **Issue and Receipt of Arms**

17. At the time of arms, the contingent Commander/JCO incharge Contingent will be present and get the arms issued for training. The cadets will not enter the Kote. JCOs with the help of the Kote NCOs will deliver the arms to the cadets outside the kote.
18. The kote JCO will enter, all arms in the kote Register with their but number, as per the Directorate Number, in the issue Register. The Contingent Commander/JCO in-charge will sign for the weapons issued to them.
19. One receipt of Arms the kote will ensure. that all weapons are intact and not damaged. He will also ensure that the weapons are clean.
20. Thereafter chains will be locked under the supervision of the Contingent Commander/ JCO-in-charge Contingent.
21. Private arms will be entered in a separate register.

### **Security**

22. The Kote NCOs will stay in their respective kotes. They will sleep in the portion properly partitioned from the main portion of the Kote where the weapons are kept, They will use the main entrance of the Kote.
23. Proper handing/taking over will be carried out daily between the Kote JCOs and the Night Guards. Proper entry will be made to this effect in the register kept in kotes.
24. The original key of the chain locks for Contingents will be with the Kote NCO.
25. The duplicate key of the chain locks will be deposited. with the Dy Camp Comdt.
26. The weapons will be cleaned properly before depositing in the Kotes. The Contingent Commanders will ensure that before depositing, these are cleaned properly.
27. Extra time may be allotted by the Contingent Commanders for its purpose.

## RECEPTION OF VISITORS : RDC

### General

1. NCC Republic Day Camp is held in January every year. Many VIPs are invited to visit the Camp. A number of other visitors including the parents/relatives of children also visit the camp to meet their children and see the various activities displayed during the camp.
2. The Aim of this SOP is to lay down the reception and management of visitors, coming to RD Camp.
3. (a) Seating Arrangements: Proper seating arrangements will be made in the Reception Centre for visitors. It will accommodate approx 30 personnel including cadets.
 

(b) Store Tent: Store Tent in good condition will be pitched up opposite to the main gate of girls area and on one side of the shopping complex.

(c) Furniture : The following furniture will be provided by adm Dte:-

(i)	Sofa Sets	(5 seater)- 4
(ii)	Easy chairs nylon. string folding	- 12
(iii)	Tabl folding 4' X 4'	- 4
(iv)	Centre tables	- 4
(v)	Peg Tables	- 12
(vi)	Ashtray	- 4 (from Camp)
(vii)	Flower Vase (Brass)	- 6 (from Camp)
(viii)	Carpets 6' X 9'	- 6
(ix)	Drinking water arrangements	- (from Camp)
(x)	Display of Photos	- (DD Publicity)
(xi)	Tube lights	- 4

### Communication

4. One to one communication will also be provided between the Reception Centre and the Camp Adjutant. Announcer's booth will be established next to the reception Centre with a parallel PA System on the Camp broadcasting system. This will be utilised to call cadets concerned.

### Telephone

5. A PCO Telephone will also be provided in the Reception Centre for use by the visitors. This telephone will be provided by P&F Dte. Installation of TV
6. A TV set will be installed in the visitors tent and the NCO detailed will be responsible for the operation and maintenance of the same. TV set will be provided by P&F Dte.

### Visitor's Book

7. A visitor book will be kept in the reception room for signature and remarks of the visitors. This will be procured by the Adm Dte. News Papers, Magazines and Periodicals

8. The following newspapers/megazines will be provided in the Reception Centre wef 01 Jan to 31 Jan by DDG (Adm) :-

- |     |                    |       |
|-----|--------------------|-------|
| (a) | The Times of India | - One |
| (b) | The Statesman      | - One |
| (c) | Hindi News papers  | - Two |
| (d) | Illustrated weekly | - One |
| (e) | Dharmayug          | - One |

### Detailment of Staff

9. The Staff for the Reception Room will be organised as follows and work in two shifts from 0900 hrs to 1500 hrs and 1500 hrs to 2100 hrs:-

(a) OIC Reception : An officer by name will be appointed as OIC Reception Centre for RDC. He will be the Understudy Camp Comdt. He will be assisted by one JCO and one PI Staff.

(b) Other staff will be as under:-

#### Boys

- |              |       |
|--------------|-------|
| (i) PTO      | - One |
| (ii) NCO     | - One |
| (iii) Cadets | - Two |

#### Girls

- |                     |       |
|---------------------|-------|
| (i) PTO - Lady Offr | - One |
| (ii) SMI/GCI        | - One |
| (iii) Cadet         | - One |

The above personnel will be detailed by the Camp Comdt.

(c) During 1600 hr to 1800 hrs two addl boys and girls cadets will also be detailed.

### Publicity Material

10. Suitable photographs depicting NCC activities will be displayed in the Reception Centre. Certain Pamphlets/literature/periodical published by the Publicity will also be kept, These will be provided by DD Publicity.

## INSTRUCTIONS FOR FIRE FIGHTING DURING NCC REPUBLIC DAY CAMP

### General

1. The prevention of fire is of vital importance and should be the first consideration of all. Prevention of fire is far more important than fighting the fire. Most of the fires can be prevented by common sense and good discipline and it is most important that the highest possible standard of fire prevention should be achieved and maintained so that losses by fire can be reduced to a minimum.

2. All fires are of small size in the beginning. They grow rapidly into large fires. Speed in tackling a fire is, therefore, of paramount importance. Even if fire is not completely put out its chance of growing into a still bigger fire would, however, be eliminated.

### Compliance

3. These orders are required to be read by all officers and PI Staff within 48 hours of their arrival in the Camp.

4. It is duty of all Contingent Commanders to read out and fully explain the contents of this order to all the Cadets.

5. Neglect to comply with the orders contained here-in will constitute a breach of complying with the orders under the Army Act in case of Service Personnel. In the case of non-compliance by civilians, it will result in appropriate departmental disciplinary action taken against them.

6. A copy of this order will be prominently displayed in the following offices :-

- (a) Deputy Camp Commandant.
- (b) MTO.
- (c) Adjutant.
- (d) Ration Stand.
- (e) Contingent Commanders Offices/living accommodation.

### Chain of Responsibility

#### 7. The Chain

(a) The primary responsibility for guarding life and Government property against loss due to fire rests with all individuals, whether they are combatants or civilians.

(b) The Camp Commandant is responsible to ensure that those under him are aware of the duty and implement the instructions laid down by him in this respect. In this task, he is assisted by the Dy Camp Comdt.

(c) The Station Commander shoulders the overall responsibility of ensuring that all units/Commands in the station are adequately protected against fire risks. The Station Fire Committee works on behalf and under the orders of the Station Commander.

## 8. Responsibility

- (a) The ultimate responsibility for the efficient fire fighting arrangements in the Camp rests with the Camp Commandant assisted by the Dy Camp Comdt who is the Fire Fighting Officer.
- (b) Every officer, employee and cadet has an individual responsibility to be fire minded, in that it is his/her duty to ensure that whilst he himself/she herself does nothing to prejudice the effective in the fire fighting measures he/she does everything in his/her power to preserve and promote it. To achieve this aim all personnel should do the following.
- (i) Must be always alert and vigilant.
  - (ii) Should have a complete picture of the nature and extent of Government property in the Camp.
  - (iii) Should observe all fire fighting precautions.
  - (iv) Should know the fire risks involved at his place of duty.
  - (v) Should be fully conversant with the camp fire orders.
  - (vi) Should know the operation, maintenance and location of all fire fighting equipment in the camp.
  - (vii) Should know the action to be taken in case of outbreak of fire.
  - (ix) Should bring to the notice of his next senior any difficulty experienced. in safe-guarding government property against fire risks.

9. To facilitate control and ensure adequate distribution of minor equipment the Camp has been into five sectors, as per details given below :-

Sector I	-	MT area.
Sector II	-	Administration area.
Sector III	-	Girl Cadets Area.
Sector IV	-	Boy Cadets area.
Sector V	-	Training Area.

### **DETAILS OF FIRE FIGHTING EQUIPMENT AND WAER SUPPLY AVAILABLE**

#### **Fire Fighting Equipments.**

10. The Camp is authorised only minor equipment. At each Sector Fire Point equipment as under will be kept ready for use at all Cook Houses.

#### **Water Supply**

11. There are no static storage water tanks located in the Camp except the shipmodel tank which will be kept full always. All the 45 gallon drums and water buckets at the fire points will be kept full. Running water taps in the bathrooms and cookhouses will be used.

12. The Fire Officer (Dy Camp Commandant) is responsible for examining all the equipment and for ensuring that they are always in working condition. He is also responsible to train required staff in using and refilling the fire extinguishers.

#### **Fire Precautions.**

13. **General** A fire is better prevented than actually fought out because though it can be successfully fought, it is bound to cause loss of property and sometimes even life. All Camp staff and cadets, therefore, must realise at all time that preventive precautions are of paramount importance and will be taken by all.

#### **Cleanliness and Tidiness**

14. Buildings, Tents wings, Office and MT parks will be kept clean at all times. Cleanliness and tidiness effectively reduces the danger of fire and all stuff in MT Park, should be stored outside and dug in a bed of sand. Any waste, straws or any other inflammable material is not permitted except in the bins provided for the purpose. Bins should be cleaned daily and the contents burnt under supervision.

15. Oil, grease, paints for use in cook houses and in MT Park, should be stored outside and dug in a bed of sand. Only foam type extinguishers are used in case of outbreak of fire.

#### **Kindling of Fire**

16. Open fire is allowed only in the Cook House and near the bath room for heating water for bath. This should be extinguished at the end of the day.

#### **Smoking**

17. One of the most common causes of fire is the careless handling of smoking materials. Smoking is the biggest danger in Camp from fire point of view. Careless discarding and throwing of ends, therefore, is strictly prohibited. Ash trays on office tables and tins in tents should be provided.

#### **Lights**

18. All electricity connections in the Camp Area are of temporary nature and need special precautions by all. No connections other than given by the MES will be taken. All these fittings should be inspected daily by the MES staff on duty. Whenever there appears to be any defect like loose wiring, faulty switches/plug points and naked wiring resulting in short circuiting those will be immediately brought to the notice of MES staff on duty. Electricity will be cut off during heavy rains, lightning and storms under a central arrangement.

#### **Fire Defence Plan**

19. Fire alarm will be raised immediately on detection of a fire or when holding a fire practice. It will be raised by the following persons.

- (a) First by person (s) discovering fire.
- (b) Then by those person who are in the vicinity of fire.
- (c) By those who rush/arrive on the scene of fire subsequently.

#### **How the Alarm is Raised**

20. The various methods of raising fire alarm are given below:-

- (a) By Word of Mouth The person discovering the fire ort when a fire situation is given in a fire practice will shout at the top of this voice (Aag, Aag, Aag), to attract attention of other. He will continue to shout "FIRE" "FIRE""FIRE" until the alarm is picked up by all in the Camp.
- (b) By Sounding of Gong. These consist of iron rails/gongs partly painted red suspended with the help of a string/wire at each fire point. The fire alarms will be raised by sounding the gongs and it will be continued until such time the personnel in the Camp are mustered into their respective fire parties in response to this alarm raised.
- (c) By Telephone. In the case of fire ring up the following:-
- (i) Army Camp Duty Officer.
  - (ii) Duty Officer, Delhi Area-No.25693392.
  - (iii) Duty Officer, Station HQ-No. 25691843.
  - (iv) Duty Officer, COD-No. 25693411/43.
  - (v) COD Fire Station-N0. 25693411/39.
  - (vi) COD Delhi Cantt 13927/73071/78771.
- (d) All the messages conveyed to the above telephones in connection with fire will invariably contain the following information:-
- (i) Whether it is a major or minor fire.
  - (ii) Whether it is an electrical material or FOL Fire.

### **At Each Sector**

21. Personnel in each setor are responsible for fighting fire with First Aid Fire Fighting appliances in the initial stage. All available personnel will be organised into various fire fighting parties as detailed below:-

- (a) Fire Bucket Pagty. Will form a chain for conveying water from the sources of water to the scene of fire promptly. The buckets will be kept half filled with water.
- (b) Sand Bucket Party Will form a chain for conveying sandr from source to the scene of fire promptly. The buckets will be kept half filled with dry sand.
- (c) Extinguisher Party. Will collect and operate extinguishers on the scene of fire. The extinguishers will be kept in working condition at all times.
- (d) Salvage Party Will carry out salvage at the scene of fire, Salvage, as applied to fire fighting is essentially the prevention of reduction of damage from indirect causes such as heat, smoke, water, breakage and dirt. Every effort should be made to start salvage work along with firefighting. Almirahs/cup boards/lockers marked with diagonal white cross and valuable stores should be removed to safe place.

### **Training in Fire Fighting**

22. Training in fire fighting is of primary importance for all staff and cadets. As the camp starts establishing, daily one period should be allotted for all to know their area, camp fire points and water points etc. A practice a day in all sectors by rotation must be held.



**DUTY OFFICER REPORT**

No \_\_\_\_\_ Rank \_\_\_\_\_ Name \_\_\_\_\_

## Instruction :-

- (a) Your duty commences from 1000 hrs and terminates at 1000 hrs the next day.
- (b) You will be accompanied by Duty NCO of the day, for all duties
- (c) You will report to the Camp Comdt at 1000 hrs on the commencement / termination of duty.
- (d) At the end of the duty, this form will be filled and submitted to the Camp Comdt by 1000 hrs.

1. I was duty officer for the day from 1000 hrs on \_\_\_\_\_ Jan  
 \_\_\_\_\_ to 1000 hrs on \_\_\_\_\_ Jan  
 I reported to the Camp Codt for orders at \_\_\_\_\_ hrs.

## 2. Visited the following cook houses and dining halls as under:-

- (a) No 1
- (b) No 2
- (c) No 3
- (d) No 4
- (e) No 5
- (f) No 6 ) PI Staff/Camp Staff)
- (g) No 7
- (h) No 8
- (j) No 9 (SMI)
- (k) Jcos Mess
- (l) Officers' Mess

I have following to report :-

---



---



---

## 3. I carried out inspection of the following:-

- (a) Girls Area on \_\_\_\_\_ at \_\_\_\_\_  
 (Not to be visited between 2100 hrs to 0800 hrs)
- (b) CSD Canteen on \_\_\_\_\_ at \_\_\_\_\_
- (d) Shopping Complex on \_\_\_\_\_ at \_\_\_\_\_
- (e) Reception Room on \_\_\_\_\_ at \_\_\_\_\_
- (f) Information Hoom on \_\_\_\_\_ at \_\_\_\_\_

My comments on Para 3 are as under :-

---



---



---

4. I visited MI Room on \_\_\_\_\_ at \_\_\_\_\_. There were \_\_\_\_\_ patients from the Camp. I have following remarks to make:-

---

---

---

5. I attended the morning sick report on \_\_\_\_\_ at \_\_\_\_\_. Comments are as under:-

---

---

---

6. I visited Bath Rooms/Latrnies on \_\_\_\_\_ at \_\_\_\_\_. My comments are as under:-

---

---

---

7. I have checked the perimeter wall/fencing of the camp area on \_\_\_\_\_ at \_\_\_\_\_.

My observations and action taken on that are as under :-

Observation    Action Taken

- (a)
- (b)
- (c)
- (d)
- (e)
- (f)

8. I checked the passes of following civs and attached persons and have following observatons:-

---

---

---

9. I have checked receipts of rations/fresh on \_\_\_\_\_ My comments are as follows:-

---

---

---

10. I checked the Hot water arrangements at \_\_\_\_\_ hrs. My comments are as follows:-

---

---

---

11. I inspected the Kote on \_\_\_\_\_ at \_\_\_\_\_. My comments are as follows:-

---

---

---

12. I visited the Army Hospital/Base Hospital on \_\_\_\_\_ at \_\_\_\_\_  
\_\_\_\_\_. (Only if any patients are admitted. To be ascertained from the MO I/C MI Room).  
My comments are as under :-

\_\_\_\_\_  
\_\_\_\_\_  
\_\_\_\_\_

13. I carried out fire fighting practice on \_\_\_\_\_ at \_\_\_\_\_  
\_\_\_\_\_. (Date and time to be ascertained from Camp Comdt). I have following  
points to report :-

\_\_\_\_\_  
\_\_\_\_\_  
\_\_\_\_\_

14. I visited MT Park at \_\_\_\_\_ on \_\_\_\_\_  
My comments are as follows:-

\_\_\_\_\_  
\_\_\_\_\_  
\_\_\_\_\_

15. Important general comments/obsen/atons relating to :-

(a) Security : \_\_\_\_\_  
\_\_\_\_\_  
\_\_\_\_\_

(b) Hygien : \_\_\_\_\_  
\_\_\_\_\_  
\_\_\_\_\_

(c) Discipline : \_\_\_\_\_  
\_\_\_\_\_  
\_\_\_\_\_

(d) Any other points : \_\_\_\_\_  
\_\_\_\_\_  
\_\_\_\_\_

Dated:

(Signature of duty Officer)

**COMMENTS IF ANY**

1. Camp Comdt
2. DDG (Adm)
3. Secretary RDC
4. JD (DV
5. ADG (B)

## STANDING OPERATING PROCEDURE PHOTO SHOP RDC

### Introduction

1. A Photo Shop will be set up at RD Camp to provide photographs of various activities and events connected with RD Camp at reasonable rates to the cadets. For smooth functioning of the shop officers and personnel as shown in the organisation chart will be attached to the Photo Shop from DGNCC and different Dtes. The Photo Shop will function under the overall supervision of DDG (P&C) through Officer Incharge Photo Shop.

### Organisation

2. JD (Pub) will be OIC under supervision of DDG (P&C).

### Charter of Duties

3. Officer Incharge Photo Shop

(a) to arrange the services of Civilian/Service photographers who will take photographs of all activities of the RD Camp under his direction.

(b) To purchase films and other items required for Photo Shop and arrange developing and printing at competitive rates. For this purpose he will invite quotations from various photo studios to undertake the task of processing and printing. The job content is given below:-

- (i) Daily collection of exposed films from the RD Camp Photo Shop.
- (ii) Delivery of first prints promptly at the RD Camp Photo Shop.
- (iii) Numbering of each print before delivery.
- (iv) Collection of orders for reprints.
- (v) Prompt delivery of reprints. .
- (vi) Numbering of each reprint before delivery.

(c) To get the order forms and compilation charts printed before the commencement of the RD Camp.

(d) To liaise with Camp Commandant for smooth functioning of Photo Shop.

(e) To supervise and direct functioning of the teams mentioned in para 2.

(f) To ensure proper maintenance of documents and accounts.

(g) To draw money from RD/Regimental fund for purchase of films and other items.

(h) To procure suitable display boards and necessary items for display of photographs.

(j) To collect daily cash and disburse to the Photo Studio as per orders placed.

(k) To ensure despatch of photographs to the individuals after the completion of RD Camp. .

(l) To finalise accounts and carry out a local audit.

(m) To submit a report to DDG (P&F) / ADG (A).

4. **Asstt Officer Incharge Photo Shop**

- (a) To assist the Officer Incharge Photo Shop in daily routine work.
- (b) To carry out the duties of Officer Incharge Photo Shop in his absence.
- (c) To ensure proper administration and security of the Photo Shop.
- (d) To ensure availability of transport as and when required.
- (e) To exercise control and instruct the potographer to cover various activities/events at the appropriate time.
- (t) To ensure proper eventwise display of Photos on display boards.
- (g) To collect compiled demands of the day and handover to the Photo Studio.
- (h) To receive photographs from the Photo Studio as per the demands placed.
- (j) To ensure preparation of reord albums and master negative albums.
- (k) To ensure proper delivery of photographs to the cadets.

5. **Accounts Officer.**

- (a) He is required to supen/ise the maintenance of accounts of the Photo Shop.
- (b) He will also oversee the work of the clerk,
- (c) He will check all ledgers and cash book every day.
- (d) At the end he is to finalise the accounts and prepare a statement of accounts.

6. **Accounts Clerk**

- (a) He is to maintain all files, documents, ledgers and cash book of the photo shop.
- (b) He is to check summaries of daily orders received and money collected.
- (c) He is to collect all the bills/cash memos everyday and bring the items on charge.
- (d) He will bring the ledgers -and cash book upto date every day and show it to Accounts Officer/Officer incharge Photo Shop.

7. **Team 'A'**

- (a) Will be responsible for maintenance of documents.
- (b) Will be resposible for eventwise display of photos on display boards.
- (c) Will ensure that the photographs displayed are correctly numbered.
- (d) Will ensure that the photographs are displayed atleast 2 to 3 days continuously before removal.
- (e) Will prepare record albums once the photos are taken off from the display boards.

8. **Teams 'B' & 'C'**

- (a) Will book orders, colect money and issue receipts. Orders will be accepted till the last day of display of photographs.
- (b) Will handover the cash collected during the day to the Officer ncharge Photo Shop at the end of the day.
- (c) Will maintain receipt books.

- (d) Will compile the orders booked at the end of the day.
- (e) Handover the compilation sheets to Asst Officer incharge Photo Shop.
- (f) Check quality and quantity of photographs when received and compare with the orders placed.
- (g) Prepare distribution envelope as per the orders books.
- (h) Deliver these envelopes to the individuals from the delivery counter as and when the envelopes are ready. The envelopes which are made ready after 30 Jan are to be despatched by post.

### **Timings**

9. The Photo Shop will be kept open from 0900 hrs to 1300 hrs and 1500 hrs to 1900 hrs daily for display of photographs, booking of orders and delivery of photographs. The timings are subject to changes necessitated due to Adm reasons/Camp routine. Separate counters for boys and girls will be made for booking of orders. Money will be paid at the time of booking of orders.

### **Duration of Display**

10. Each set of photographs will be displayed for 2 to 3 days so that every individual gets a chance to see the photographs. However, period of display of photographs for RD Parade, PM Rally, PM Lunch and President's 'AT HOME' may be possible only for one or two days.  
Lightage and furniture.

11. One store tent will be earmarked for display of photographs and one EPIP tent will be utilised as office and for booking of orders. Furniture items will be provided by Adm Dte as per the list given below :-

(a)	Office table 4'x3'	- 5
(b)	Chairs with arms	- 10
(c)	Steel Almirah (small)	- 3
(d)	Complete set of tube light	- 8
(e)	Dust Bins large	- 4
(f)	Door mats	- 4

### **Vehicle**

12. One vehicle preferably Jeep/Gypsy will be required for the photographer to cover the functions outside the camp. This vehicle will be used on need basis only.

**SOP FOR FINANCIAL MANAGEMENT IN RDC  
SUBMISSION OF ESTIMATE TO THE P&F DTE OTHER THAN MESSING ACCOUNT**

1. The P&F Dte will issue a circular to all Internal Directorates of DGNCC and NCC Delhi by '15 Jul for projection of estimates of expenditure for the items/events of RDC death by the concerned Dte. NCC Dte will also submit the estimates for the events entrusted to that Dte.
2. The estimates should be received in the P&F Dte by 16 Aug. Based on the estimates projected by the different Dtes, the P&F Dte would submit the proposal to Min of Def for obtaining sanction and Endeavour to get the same by 30 Oct.

**COMPLITION OF CONTRACTS AND PROJECTION OF REPUBLIC ESTIMATES**

3. The internal Dtes while projecting the estimates would ensure that the estimated expenditure is realistic and supported with the facts and data. Wherever tenders are to be published in the News papers and contracts to be entered for the supply of service/goods, the same are to be executed and estimates/contractual amount should be Projected to the P&F Dte before submission of the case to the Govt.

**ALLOCATION OF FUNDS/MAINTENANCE OF ACCOUNTS.**

4. On receipt of Govt sanction, the P&F Dte would plan expenditure for various items/events of the central funds with the approval of the DG and intimate to all concerned internal Dtes including Delhi Dte. The actual expenditure should not exceed the amount allocated by P&F Dte. This would include expenditure on Fuel for boilers for heating water.

**CONTRIBUTION FROM STATE DIRECTORATES TOWARDS MESSING AND INCIDENTAL**

5. The P&F Dte would issue a letter to all State Dtes requesting them to forward the bank drafts towards messing and incidental expenditure of contingents participating in the RDC. The letter should clearly indicate the rates of contribution toward messing allowance and incidental allowance in respect of participating cadets and PTOs. The bank against which the draft has to be drawn and the name of the account should be clearly indicated. Letter will be issued by 25th Jul instructing the Dtes to forward contribution by 10 Dec. The list of defaulting Dtes will be put to DG (B) for directions.

**BANK ACCOUNT**

6. The P&F Dte will open separate Bank accounts - one for messing and incidental allowance amount received from State Dtes and another Bank Account for all the Central Govt Funds sanctioned specially for the FIDC.

**ACCOUNTS OF CENTRAL GOVT FUNDS**

7. The accounts of Central Govt funds will be maintained as per the prescribed procedure by the AO and his staff under the supervision of DIFt(Fin)/Dy DIR (Fin). It has to be ensured that after the Camp is over, by end of Mar all the bills for which the payments have to be made by the Central Govt funds are settled. The remaining balance is to be returned to Govt through MHO. The adjustment bills are to be forwarded to CDA(HQ) ith supporting vouchers/receipts by 15 May.

## ACCOUNTS OF STATE FUNDS

8. Dir (Fin)/Dy Dire (fin) will keep separate account of the funds pot messing and incidental allowance. This account will be audited by the Dir of Audit, Central Revenue after the Camp is over. It is, therefore, to be ensured that all the expenditure is duly supported with vouchers and receipts. Details procedure for procurement and accounting of supplies is out lined in this appendix.

## COMMAND AND CONTROL OF FINANE WING OF RDC

9. The following will be the structure of the organisation for submission of the proposals for sanction of expenditure from the RDC Funds:

DG <> Addl DG (B)<> DY DG P&F <> DIR (Fin) Dy Dir (Fin) <> AO (Central) <> AO (Messing Funds, Contingency & incidental)

## FINANCIAL POWERS

10. The competent authority to sanction the expenditure including the aance from RDC Funds in respect of all the RDC Funds will be as under :-

Authority	Amount per item
DG	Full Powers.
ADG(A). ADG (B)	Rs Two lakhs per transaction
Dy DG(P&F)	Rs 50,000/- per transaction.
Dy DG (Logistics)	Rs 50,000/- per transaction in A respect of dry/fresh ration.
Camp Commandant	Rs 1,000/- per transaction subject to a maximum of Rs 10,000/- during the period of entire camp to meet day to day emergent nees of miscellaneous requirements.

## Cash Balance

11. Amount not exceeding Rs 10,000/- (Rs ten thousand only will be kept in cash by the concerns AO, during the camp to meet any unforeseen eventuality and petty/urgent payments. The safe custody of the cash will be the responsibility of the concerned A0 Dir (Fin)/Dy Dir (Fin) would carry out inspection of the cash in hand at least once in a week.

## SUBMISSION OF DAILY ACCOUNTS FROM 01 JAN TO 30 JAN BY THE FINANCE WING OF THE RDC.

12. Dir (Fin)/Dy Dir (Fin) will submit daily accounts of actual expenditure incurred and advances paid from the following accounts:

- (a) State Messing account.
- (b) Incidental Grant
- (c) Contingent Expenditure
- (d) Laboury
- (e) Special messing.

Performa for submission of daily statement of expenditure is given at Annexure I.

## SUBMISSION OF PROPOSAL FOR EXPENDITURE ON Various ITEMS / EVENTS CONNECTED WITH RDC

13. The requisition or expenditure from the RDC funds as advance settlement of bills will be submitted as per the Performa given at Annexure II and III (Annexure II - Central Govt and Incidental, Annexure-III, Messing Funds). The Performa will be submitted in the relevant file of RDC with a brief not on a minute sheet indicating details/reasons for incurring the expenditure. On receipt of the file JD (Fin) would submit the file to the Competent Financial Authority for obtaining his sanction. If the approval needs to be reconsidered by the initiating section/Dte the file will be returned after



showing it to the Dy DG (P&F). JD (fin) would ensure that there is no undue delay in disposing the requisition. The officer submitting the requisition should also ensure that the expenditure proposed is for the items connected with the RDC and it is purchase Committee may demand cash twenty four hours in advance on as required basis from Dir (Fin)/Dy Dir(Fin)., who after the payment will call for adjustment bills within 48 hours of payment.

### **PURCHASE COMMITTEE**

14. All purchases out of RDC-funds, excepting items procured Ex ASC, should be made by a Purchase Committee to be detailed by DDG (Org). During the duration of the Camp the composition of the Purchase Committee shall be as under:

- (i) Presiding Officer - Regular Officer NVTO
- (ii) Members (3) - One NCC Officer, Two Senior Cdts.

Note: The personal of the Committee will be changed every week and this will be published in Camp Order.

15. The procedure to be followed by purchase committee, after approval of Competent Authority has been obtained, will be as under:

- (a) Presiding Officer assembles the Committee.
- (b) Make purchase as per laid down procedure.
- (c) The stores purchased along with the bill/cash memo and proceeding duly signed by the Purchase Committee will be handed over to GM/officer requisitioning the supplies/stores. A receipt of the same will be with number, Flank and name of the store holder be capital letters, to when these documents with stores have been handed over.
- (d) QM/store holder will check quantity/quality of the stores with reference to bill and take the store on stock letter by means of a CRV immediately before issues are make. The store/supplies will be issued without taking charge.
- (e) QM/Store will pass on the bill along with proceedings of the purchase Committee and CRV to Accounts Officer within 24 hours of receipt of the store.
- (f) Accounts officer will retain the board proceeding after checking their correctness from audit point of view.

This procedure will be followed for all types of local purchase.

### **MODE OF PAYMENT**

Delete the existing entries and substitute as under:

16. Payment to contractors, vendors and other parties from whom stores have been procured, cost of which exceeds Rs 2,000/- will be more by cheque only on receipt of the bill. Bills for procurement of stores where cost is less than 2,000/- will be made preferably through cheque and production of the bill/bills from the party concerned. However, the payment less than Rs 2,000/- can not be made in cash also it the party insists for the same.

### **17. SUBMISSION OF ADJUSTMENT BILLS**

18. Adjustment bills for the advance drawn from the AO on the authority of the pary order, duly sanctioned by the Camp Authority will be submitted to the concerned Camp AO for adjustment and booking of the expenditure under the relevant head of a accounts within 48 hours.

19. The adjustment bills submitted to the AO will require a meticulous security in terms of the provisions containing in para 95 of accounting instructions for NCC Camps, An extract of para 95 is given at Annexure IV. Bills othenivise will not be admitted for payment adjustment.

### **Procurement and Accounting of Supplies (NCC RDC)**

20. The RDC for NCC cadets is regular feature. The Camp strength has established over the years and the administrative requirements of the Camp can, therefore, be forecast fairly accurately. These instructions lay down the procedure for procurement and accounting of supplies in RDC.

21. The main aspect needing advance planning and action are discussed in succeeding paras.

### **RATION SCALE**

22. The ration scale of a cadets to be paid from State contribution is at Annexure V. The scale of ration of items which may be purchased from Central funds is shown at Annexure VI.

23. The ration scale may be reviewed depending upon cost of items prevailing at the particular time after one week of the camp and availability of funds. An analysis of expenditure incurred on each item of ration shall be carried out by AO (Messing) every week and submitted to DDG (P&F) who in turn advises DDG (Adm) to carry out necessary adjustments as required.

### **PROCUREMENT OF SUPPLIES**

24. All items of supplies in dry and fresh rations will be procured from supply Depot Delhi Cantt. The Adm Dte will work out the approv. requirement of supplies and project the same to DDST, HQ Delhi Area under the authority of Army HQ QMG Br No 41739/Q/ST6/Q1(B) dated 13 Sep 73. In case any items are not available in supply depot, the same will be procured from State Co-operative Stores Super Bazar. The action for procurement of supplies at various stages will be as under:

(a) Placing of demand: Adm Dte will place a provisional demand of supplies on supply Depot Delhi Cantt through DDST, HQ Delhi Area. This will include dry supplies, ' fresh supplies including milk and fuel for cooking.

(b) Procurement of ration Ex-supply Depot: The QM (Supply) RDC will prepare a etailed demand of stores required. He will V place an indent for the requirements on supply Depot who will price it and return it to QM (Sup) for depositing the money in treasury and obtaining MRO to be handed over to supply Depot. The demand of dry supplies will be one in two parts as under:

(i) First indent for 15 days.

(ii) Second indent for balance days taking into account the rations left over from the previous indent.

(c) Procurement of stores from Civil Market:-In case any item of ration is not available with Supply Depot Delhi Cantt, the same will be procured from Super Bazar/ Govt undertaking/Civil Market. These will be procured by the Purchase Committee on orders of Camp Commandant.

(d) Miscellaneous Items - Any special item not forming part of routine Menu, required to be purchased on special orders will be responsibility of Camp Comdt. He will arrange the funds for such items by obtaining the approval of CFA on minute sheet and direct the purchase committee accordingly.

25. Disposal of Stores - The unconsumed rations should be minimal if the indents are correctly prepared. However, on termination of the Camp, the balance of rations will be intimated to Dy DG (Adm).The rations will then be sold first to the Camp Cook House and subsequently to other authorised persons as per entitlement. The money recovered will be refunded to P&F Dte. A nominal roll of persons to whom the surplus rations are sold will be made and attached to documents maintained for RDC.

26. Accounting Procedure - Normal accounting procedure will be adopted for RDC. QM (Sup) will take all items of rations on ledger charge. The subsequent distribution to cook houses will be made as per ration scales fixed earlier. The specific responsibilities of various appointment will be as under:

QM (Supply) - As brought out earlier, he will be responsible for planning and procurement of Dry and Fresh supplies as per ration scale approved by the DG. The issue to Mess/Cook Houses will be as per demand of various Mess/Cook Houses.

27. Issue of Ration: - Ration will be issued to Messes as follows:

- |     |  |                 |
|-----|--|-----------------|
| (a) | Dry Ration                               | - Once a week   |
| (b) | Fresh Ration                             | - Thrice a week |
| (c) | Milk, Bread, Chicken,<br>Meats and Eggs. | - Daily         |

28. Ration will be issued to Messes based on the feeding strength in Cook House, approved scale of ration and menu for the days. The indent prepared by the JCO i/c of each Cook House on form as shown at Annexure VII (in quadruplicate) will be countersigned by Messing Officer the rations are to be drawn. AO (Messing) will check the indent for correctness of demand as per ration scale and thereafter handover the indent to QM (Sup) for making the issues. indents for special Messing will be prepared separately. The distribution of indents will be as under :

- |     |             |
|-----|-------------|
| (a) | Cook House  |
| (b) | JCO i/c Sup |
| (c) | QM/Supply   |
| (d) | AO Messing  |

Delete the existing entries and renumber the para as 29 had substitute as gnger:

29. Dry/fresh rations will be issued strictly with conference to scale and strength and as such ration issued to the messes will be treated as consumed and the daily messing will be worked out on the basis of ration issued to Messes. For working out the daily messing by (Messing) the QM (Supply) will pass on the issue. vouchers duly priced to AO (messing) on daily basis.

30. Delete the existing entries, renumber the para as 30 had substitute as under:

31. Issue of rations to officers' JCOs and NCOs Messes will be prepayment basis. Officer-in-charge JCOs, in charge of NCOs messes will collect the messing charges in Fis 25/- and Rs 15/- per dining member respectively per day from the dining members in advance from the date of drawing the rations from QM (Supply) to the end of the Camp and will deposit the entire amount with AO (Messing). AO (Messing) will issue a receipt of the amount received. JCO-in-charge of the mess will prepare the indent for dry, fresh and special ration separately according to menu of the day and submit the same to QM (Supply) for checking and pricing. After checking, the indent will be passed on to AO (Messing). The AO (Messing) after ensuring that the pricing has been correctly done, will pass on the indent (QM (Supply) for issue of the ration.

32. It shall be the responsibility of the Messing Officer to collect and deposit the cost of ration and Cooking Charges issued to cadets and Contingent Staff for the Pre and Post dates of the actual Camp period. The actual Camp duration is from 05 Jan to 29 Jan.

33. Documentation : All documentation will be one on registers/forms issued by Adm Dte for RDC. All registers will be serially numbered and initialed by an Officer before RDC. All these documents will be handed over to QM (Supply) at the end of the RDC.

34. Audit - QM (Supply) will be responsible to furnish all documents to P&F Dte for getting the accounts audited by Director of Audit, Central Revenue (DACR), in terms of para 143 to 147 of SNCCO I/S/90, Vol I.

**CHAPTER-III****TRAINING, MAJOR EVENTS, PRIZES, PM'S RALLY AND FOREIGN CADETS****PART I - TRAINING****Aim of Training Activities During RD Camp.**

1. Training during RD Camp is aimed at the following:-
  - (a) Selection and preparation of NCC Marching Contingents and the NCC Bands for the National Republic Day Parade at Rajpath on 26 January.
  - (b) Selection and preparation of Guard of Honour.
  - (c) Selection and preparation of cadets for display of para sailing out slithering.
  - (e) Keep uncommitted cadets usefully engaged so that they learn new skills/subjects and draw maximum benefit from the camp. For this purpose contingent commanders will nominatone part time officer and maximum available PI staff from con. tlngent staff.
  - (f) Peperation and conduct of Horse Show, Band display and PM's Rally.

**Responsibilites**

2. The DDG (Trg) of DGNCC willbe reponsible for organising all training activities during the Camp. He will be assisted by officers of Training Dte, CTO and OIC FI&V Dets. Director Training will be responsible to DDG (Training) for organising prize distribution at various function. DD Trg (YEC) will be responsible for organising and conducting foreign cadets programme.

**Camp Training Staff**

3. Training team will consist of Chief Training Officer (CTO) and Dy Training Officers.
  - (a) Chief Trg Officer.
  - (b) Guard of Honour Officer in Charge (OIC).
  - (c) Rajpath Marching Contingent OIC along with Asst Offr (WTLO)
  - (d) PM Rally Contingent OIC.
  - (e) Balance Cadet Trg Officer
  - (f) The Trg team will be supported by reqquisite support staff (PI Staff, Drill Instructors, Clks, Vehicles, runners etc).
4. In addition, the Camp Comdt, will detail such Officers and PI Staff from amongst camp staff, who are not otherwise committed, to augment training staff as and when additional assistance is required.

**Parade Timings.**

5. Training will be conducted as per detailed Camp Programme issued by Secretary RDC. Stress will be on achieving uniformity, perfecting the timings and coordination for Guard of Honour and NCC RD Parade Contingents. Special attention will be towards rectification of defects and achieving perfect coordination inmarching, arms swinging and arms drill.

**Training Stores**

6. Chief Training Officer accompanied by JD Trg will ensure avaiablity of training stores for the entire camp.

## PART II - MAJOR EVENTS

### Guard of Honour

7. All Guards of Honour during the RD Camp will be armed and inter-wing i.e. Army, Naval, Air and Girls Wing/Division equally represented. There will be two stick orderlies (AsDC). Military Band will be in attendance. Two NCC Bands will perform after Guard of Honour. IN & IAF Service Band will be requisitioned by Seceratry RDC for visit of CNS & CAS respectively. Lay out is given at **Appendix A.**

8. The following special points will be obsen/ed:-

- (a) Stick Ordellies not salute while guard presents arms.
- (b) The guard will be in two ranks.
- (c) DG NCC will march to the left & slightly behind the VIP while the Cadet Guard Cdr will march on Right & slightly behind VIP. He wil walk and NOT do "DHIRE CHAL" but will walk at slow speed keeping the toe of his boots/shoes pointing downward. He/She will not swing his/her arm during the inspection.
- (d) There will be one Cadet Guard Cdr and one Det cdr each from Army, Navy, Air and Girls. They will not carry any weapon sword or cane.
- (e) Cadets in ranks will carry rifles with slings. The girls will also carry rifles.

### RD Parade at Raipath - Strength & Composition of Contingents.

9. Marching and band contingents will be selected based on vacancies/ slots given by MoD (Ceremonial). As in vogue, two NCC Marching Contingents (one each of Boys & Girls) and two NCC bands (one boys & one girl) march on Rajpath during RD Parade.

### Order of March

10. Order of March will be as under:

- (a) SD Boys.
- (b) Band
- (c) SW Girls
- (d) Band

### Procedure for Training of the Marching Contingents.

11. Training of RD Contingents will be conducted at Garrison Parade Ground where Army Contingents also practice. Training will be conducted in two phases as under:-

- (a) Trainign till 16 Jan will be conducted at Garrison Parade Ground. For this, CTO & OIC Rajpath will prepare training and reheasal schedule within the framework of camp programme. Each cadet will be assigned a place according to his/her height and shoulders and same positions will be maintained during all practices.
- (b) Training after 17 Jan will be done along with Army Contingents at Rajpath.

12. All briefings nd debriefings in connection with RD Parade rehearsals will be attended by OIC Rajpath. He will apprise DDG (Trg) about the points received. DDG (Trg) will, however, attend full dress rehearsal and other important meetings/rehearsals.

### **Uniform and Accountments**

13. Cadets will wear terrycot uniform with Jersey Pullover and NCC colour KAMARBAND, Staff, Arms titles and black leather belts. Air Force cadets will wear black boots in place of shoes. Contingent Commanders will bring adequate stock of black belts and leather shoes including for girls cadets.

14. Girl cadets will wear terrycot shirts tucked in and slacks with Jersey Pullover and leather belts and black shoes. They will not carry rifles.

### **Adm Requirements**

15. The OIC Rajpath will liaise with Camp Comdt/MTO and arrange the following:-

- (a) One light vehicle and adequate number of buses for cadets and bands.
- (b) Drinking water, refreshment and extra diet sanctioned by ADG (B).

### **Bands and Buglers**

16. RD Cell will approach AG's Branch, Army Headquarter (CW Dte) for detailment of a Service Bands (One Pipe & One Military) for Guard of Honour, RD Parade and other camp functions. 12 Buglers will also be requisitioned, four from each services.

### **R & V Contingents**

17. Dtes will be allotted separate vacancies for R&V Sqns/Regt for R & V cadets to take part in Horse Show and Equestrian competitions. Horses and adm staff will arrive by 28 Dec and R & V cadets will reach along with their contingents.

### **Arrival Schedule**

18. Detailment of Regular Officers on staff of RD Camp will be issued by DG NCC (MS Branch).

### **Equestrian Competitions & Prizes**

19. The equestrian competitions including competitions for various Trophies & Cups along with other prizes, NCC Horse Show will be conducted as contained in Vol II of this book. All competitions will be conducted as per regulations and rules of Equestrian Federation of India.

### **Organisation of Horse Show and Band Display**

20. DDG (Trg) assisted by OIC R & V will be responsible to organise Horse Show and Band display at the selected venue on the day indicated in the Camp Programme. Administration will be handled by DDG (Adm). Recommended Programme of Horse Show and Band Display is at **Appendix B**.

21. **Responsibility for Horse Show.** Division of responsibilities will be as under :-

- (a) Organisation and Coordination - DDG (Trg).
- (b) Conduct of Equestrian competitions and commentators script - OIC R & V.
- (c) Provision of Judges through DG RVS. - Secy RDC
- (e) Prize Distribution Ceremony - OIC R & V.



- |     |   |  |
|-----|---|--|
| (f) | Administration including provision of furniture manpower, refreshment and the general cleanliness and lay out of Stadium. | - Camp Comdt under Supervision DDG (Lgs) |
| (g) | Ushering and guest seating  | - Dir Coord                              |
| (h) | Provision of Commentators   | - DDG (P&C)                              |

22. Administration of R & V Dets. Lgs Dte will be responsible for complete administration of R & V Dets including provisioning action for rations, accommodation for the animals, construction of hard standing accommodation and messing of civilian staff, provision of furniture for R & V Dets and Adm requirements of the Horse show.

23. Dispersal. R & V dets/horses will depart immediately after the Horse Show. Dispersal dates will, however, be got approved by OIC R & V Dets from ADG 'B' through DDG (Trg) by 07 Jan, so that contingents can confirm/arrange return reservation. DDG Lgs Camp Comdt and RD Cell will be informed accordingly. Move sanction of animals and R & V personal will be accorded by MS Dte and Pers (B&F) accordingly.

### **PART III - PRIZE, TROPHIES, CERTIFICATES AND THEIR DISTRIBUTION**

22. The trophies for various competitions counting towards RD Banner and other prizes are distributed during the RD Camp on the following occasions:-

- (a) NCC Run Trophy and individual prizes of NCC Run.
- (b) Horse Show and Band Display-Equestrian Trophies and prizes.
- (c) Cultural Show No.1 to 3 - Trophies and prizes for other Contingent and Team events, Mountaineering Trophy and Blood Donation Trophy. The distribution of these prizes and trophies will be scattered equitably during the above Cultural Shows.
- (d) PM's Rally - Batons and Trophies for winners of first position of Best Cadet Competition, PM's RD Banner and Miniature Banner.
- (e) DG's Closing Address - All remaining prizes.

23. List of Prizes and Trophies to be distributed at RDC is at **Appendix C**. This list will be reviewed every year during the month of Aug by Trg (A) in consultation with NCC Navy and Air and got approved from the DG. Approved list will be forwarded to Lgs Dte for procurement action.

#### **Division of Responsibilities**

24. RD Cell Policy on award of prizes and trophies for various competitions.

#### **25. Trg Dte (Trg A)**

- (a) Obtain DG's approval on the list of trophies and prizes and forward the same to Lgs Dte for procurement and supply. The Requirement of packing material, ribbon.coloured string required for the medals will also be indicate. Dir Trg will be Officer-in-Chare Prizes. His detailed duies are at Appendix 'H'
- (b) Brief Prizes Distribution Offr on various occasions and supervising the actual prizes distribution at various functions/occasions Dir Trg Prize Distribution Ceremony of the PM's Rally will, however, be organised by DDG (Trg). Detailed duties of Prizes Distribution Officer are at **Appendix C**.

(c) Obtain from Prize Distribution Officer and hand over to the Camp Comdt and Lgs Dte the complete record of Trophies/ Prizes taken over from Lgs Dte and particulars of the Officers/ Cadets to whom these have been distributed. The records so maintained should be authenticated duly signed by the recipient so as to satisfy the audit authorities and accounting of trophies and prizes.

(d) Printing of Merit certificates.

**26. Lgs Dte**

(a) Procure trophies/prizes, souvenirs and presentation items as per requirement intimated by Trg Dte.

(b) Collect the rolling trophies from the Dtes, get these repaired and polished and issue these on voucher to Prizes Distribution Officer by 05 Jan.

(c) Obtain complete details and particulars of the recipients from OIC Prizes and all undistributed prizes and settle the account of all prizes and trophies before 03 Feb.

(d) Arrange cardboard package of various sizes from DGNCC CSD Canteen so as to minimise the expenditure on purchase of packing boxes by the Prizes Distribution Officer.

**27. MS Dte** - Detail a JCO for prize duties alongwith the camp stall.

**28. Camp Commandant**

(a) Detail suitable PI Staff and uncommitted cadets for prizes distribution duties. These cadets once detailed will not be changed.

(b) Provide requisite table, table cloth and funds for prize distribution.

(c) Organise prompt communication of results to Contingent Commanders and organise marshalling of prize winners to OIC Prizes for rehearsal/practice.

(d) For mass prize distribution at Cultural Shows and DG's closing address, provide additional staff i.e. one Whole/Part Time NCC Officer, One GCI and one PI staff, to OIC prizes to marshal and control large number of prize winners. In addition provide 15 cadets (one announcer, eight JD cadets for Table Drill, and six girl cadets for packing).

**Expenditure on Trophies/Prizes**

29. Expenditure on polishing of trophies, procurement and packing of other prizes (including Sandal/Rose wood batons) will be debited to the Camp Funds. For this, Lgs Dte will call for tenders. OIC Prizes will obtain amount required for packing of prizes on pay order out of Camp Funds.

**Accounting of Trophies and Prizes.**

30. Trophies. All trophies will be held on charge of Trophies Ledger with Lgs (B) DGNCC. These will be collected back from DTes by 15 Aug for repair and polishing. DDG (Lgs) will convene an Annual Stock Taking Board to check correct holding of trophies as per description given in the Ledger including size, type/shape. On 03 Jan these will be handed over on a voucher to Prize Distribution Officer. On 03 Jan these will be handed over on a voucher to Prize Distribution Officer of Camp Staff who will store these in a secure place in steel almirah boxes with proper locks. Whenever trophies are presented to a winner, signature of Contingent Commander will be obtained and kept on record and issue recorded in the Trophies Ledger. Proper packing will also be handed over/taken over along with the Trophy. One copy of the issue Voucher will be sent to Dte by post Lgs Dte.



31. Individual Prizes. Prize Distribution Officer will take over all prize items from DD Lgs (B) on O2 Jan on proper voucher and keep them in safe custody. Signature of recipients will be obtained on the day any item is presented and notified in the Camp Routine Order once a week.

32. At the end of RD Camp OIC Prizes (Dir Trg) will check record of issue/receipts maintained by the Prize Distribution Officer.

#### **PART IV - PRIME MINISTER'S RALLY**

##### **Background**

33. Since 1950, every year on 27 Jan, Special NCC Rally is organised in the garrison Parade Ground, Delhi Cantt, at which the Prime Minister of India reviews the multifarious activities of the NCC. The Rally is commonly known as the Prime Minister's Rally and is attended by the RM, RRM, some senior Ministers, Service Chiefs, Defence Secretary, members of the Diplomatic Corps, Senior Civil and Military Officials and prominent public men of the national capital.

##### **Aim**

34. The aim of the PM's Rally is to display all that is good in NCC training and NCC activities before the Prime Minister and other National Leaders/Dignitaries.

35. The image of NCC is thus projected through glimpses of NCC activities to the public. This one hour Rally is conducted with clock like precision and without any interruption or passage of orders.

36. Since Jan 1985, the Prime Minister also pays a visit to the Flag Area, Photo Exhibition and Army, Navy and Air Activities Tents before proceeding to the Rally Ground.

##### **Sequence of Events.**

37. The sequence of Major Events of this Rally are as under:-

- (a) All preparations for the Rally are completed before 45 minutes of the arrival of the PM.
- (b) Invites get seated.
- (c) Guard of Honour takes up position 15 minutes before arrival of the PM.
- (d) Defence Secretary, Service Chiefs, RM & RRM arrive at Rally Ground
- (e) On Prime Minister is received by RM 7 DG NCC.
- (f) Inspection of Guard of Honour by the Prime Minister.
- (g) March past by contingent of each NCC Dte.
- (h) Heliborne Slithering Demonstration by NCC Cadets.
- (j) Army Wing Activities.
- (k) Para Sailing Display.
- (l) Naval Wing Activities.
- (m) Air Wing Activities.
- (n) Mass PT display.
- (o) NCC Song.
- (p) Prize Distribution.
- (q) Group photograph with Award Winners.
- (r) PM's Address.
- (s) National Anthem.
- (t) Departure of the PM

Note:- The exact timings of the events will be intimated by the RD Cell.

## Division of Responsibilities

47. **Trg Dte (RD Cell)** - Trg Dte (RD Cell) will be responsible for the following:-
- (a) Overall coordination and selection of new activities.
  - (b) Issue of minute-to-minute programme duly approved by DG NCC.
  - (c) Final approval of commentary script.
  - (d) Printing and distribution of Programme Card.
  - (e) Arrangements for Band & Buglers.
  - (f) Detailment of personnel other than of Delhi Dte required for the PM's Rally.
  - (g) Organisation of Group photograph with award winners.
48. **DDG (Training)**
- (a) Provision of Guard of Honour of one Commander, four detachment Commanders and 113 Rank and File of SD Army, SD Navy, SD Air, and SW.
  - (b) Provision of contingents for March past, incl R & V Mounted column.
  - (c) Organise prize distribution with the assistance of Dir Trg. Only trophies and prizes All India Best Cadets, RD Championship Banner and Miniature RD Banner will be awarded at the Rally.
49. **Dir Coord** DG NCC Coord will be responsible for the following:-
- (a) All security arrangements and for obtaining security clearance.
  - (b) Arrange security conferences.
  - (c) All traffic arrangements and control over entry of general public with the assistance of civil police. Also traffic control for PM's visit to the Camp.
  - (d) Liaison with civil police, PM's security staff and Military Police.
  - (e) Issue of invitations.
  - (f) Seating arrangement (including on Main Dais) and ushering duties.
  - (g) Escorting of VVIPs.
  - (h) Sign Posting.
50. **JD Navy** JD (Navy) will coordinate participation of Naval elements.
51. **JD Air** JD (Air) will be responsible for coordinating all Air activities.
52. **JD/DD TRG (E)** JD Trg (E) and DD Trg (E) will coordinate participation of adventure activity cadets required for march past.
53. **DD Pub**
- (a) DD Pub will be responsible for publicity, handling of Press and Photographers. He will also organise Photo Exhibition in Camp Area.
  - (b) Provision of Commentators out of AIR/Doordarshan Professionals.
54. **NCC Est.** NCC Est will make provision of flowers and plants including those required for decoration of the Main Dais.
55. **Lgs Dte** The responsibilities of the Adm Dte will be as under:-
- (a) Extension of Main Dais and provision of Saluting Base, in consultation with DG NCC/Coord and RD Cell.

- (b) Lay out of furniture on Main Dais and other seating enclosures in consultation with JD Coord.
- (c) Provision of DG NCC and Dte Flags, Flag Poles and coloured buntings all around Rally Ground.
- (d) Provision of Pyro-techniques. .
- (e) Arrangements of required number of Radio Sets, for security, traffic control and escorting duties to Dir Coord & other Rally requirements of Delhi Directorates.
- (f) Detailment of transport. Delhi Dte will be provided additional vehs for normal pageants and para sailing display.
- (g) P A Equipments and communication arrangements for community singing. Camp Signal Dficer will assist and also arrange duplicate P A System for PM's Address .& during commentary.

56 **Delhi Dte** Delhi Dte will be responsible for the following:-

- (a) DDG Delhi is overall incharge and is responsible to DG for the efficient conduct of the Prime Minister's Rally.
- (b) Provide all personnel and resources for the PM's Rally except the elements detailed from the RD Camp by the RD Cell.
- (c) Submit suggested minute-to-minute programme and any suggestions for improvements of PM's Rally, in future, to DG NCC (RD Cell).
- (d) Submission of draft script for commentary to RD Cell.
- (e) Liaison and assistance to the Coordinating Conferences after each rehearsal and pin-point short comings noticed.
- (f) Coord with Delhi Area Signal Company for PA eqptl communication arrangements in the Rally Ground.
- (g) Rally control and synchronisation.
- (h) Procurement of garland 7 bouquets for presentation to Prime Minister and his spouse and getting the same checked from PM's security staff.
- (j) Tele in Garrison Parade Ground, soon after its installation, will be regularly manned. On PM's Rally day it will be manned by an officer with two runners to be detailed by Delhi Dte.

57. **Camp Comdt** Camp Comdt will carry out the following responsibilities :-

- (a) Provision of Guard of Honour march past contingents as ordered by DDG (Trg).
- (b) Assist DDG (Lgs) in extension, layout and decoration of main Dais and ensure continuous cleaning of the area till arrival of VVIPs.
- (c) Ensure that personnel nominated from the RD Camp participate in rehearsals and in the actual Rally properly dressed and equipped.
- (d) Prepare the Camp area for the visit of the Prime Minister.
- (e) Provide officers, PI staff and cadets to JD Coord for security, ushering and traffic control duties.
- (f) Provide officers, PI Staff to OIC prizes Dir Trg for organising rehearsals of Award Presentation Ceremony.
- (g) JD Trg (E) of DG NCC will function as LO to Delhi Dte for the PM's Rally. This officer will attend all rehearsals and conferences and apprise Camp Comdt of all instructions received from DDG Delhi, DDG (Trg), DDG (Lgs), Dir Coord or Secy RDC. Camp Comdt will be responsible to ensure that these instructions are complied with.
- (h) Provide funds to various agencies as sanctioned by the DG/Add DG (B).

- (j) Ensure proper turnout and good conduct of the camp officers, camp staff and cadets during the PM's Rally.
- (k) Maintain liaison with Army RD Camp and prevent entry of any unauthorised personnel to the Rally Ground through the Camp Area.
- (l) Place demand for invitations and entry passes for all Camp personnel except those in DG NCC and Delhi Dte and arrange for distribution of these cards to the concerned individuals after collection from DG NCC/Coord. The invitation cards for individuals called to Delhi for any special activity and parents of the cadets will also be arranged by the Camp Comdt. Contingent Cdrs will approach Dir Coord for invitations for the parents of the recipients of the Best Cadets Awards and PM's Banner.
- (m) Detail NCOs to hoist DG NCC and Dte Flags on the ramparts of the Fort and who will remain in position there.

### **Running Commentary and Music**

58. From 10.30 hrs onwards when most of the invitees have arrived, recorded music of soft tunes will be played, to avoid monotony, under the arrangements of NCC Directorate Delhi. Commentators will announce the arrival of WIPs on the Main Dais.

59. There will be two commentators one in English and one in Hindi. These will be professional commentators out of panel of commentators of AIR and Doordarshan. P&C Dte will arrange the commentators Delhi Dte will nominate a suitable officer/GCI to collect the approved commentary script from RD Cell and furnish any additional information that the commentators may seek.

### **Seating Plan on the Main Dais**

60. Seats will be marked for the following on the main dais for RM, RRM, COAS, CNS, CAS, Def Secy & DG NCC:-

61. Dir Coord will get the seating plan approved from the DG. Depending on number of Minsiters invited, the number of seats in front row will be adjusted. All seats will be marked and one centre table placed in front of PM's seat. Secretary RDC will organise delivery of Programme Cards to WIPs as they get seated and forming up of award winners for Group Photograph.

## **PART V - CONDUCT AND ADMINISTRATION OF FOREIGN CADETS**

### **Adm and Joining Instructions**

62. The Adm and Joining instructions will be issued by the Trg Dte (Trg YEP) through Min of Def and Min of External Affairs.

### **Programme for Foreign Cadets**

63. Trg Dte (YEP) in consultation with RD Cell will draw up daily programme for foreign cadets to include the following:-

- (a) Visit to respective embassies on arrival.
- (b) Talk by Dir Gen NCC.
- (c) Attending Tea at Rashtrapati Bhawan & at NCC House.
- (d) Witnessing Horse Show, Air Show, Naval Show, Ceremonial parade, Cultural Shows, Army Day Parade, RD Parade and Beating of Retreat depending upon visit dates.
- (e) Conducted tours to Agra and Jaipur.

- (f) Intraction with Indian Cadets in the form of talks/group discussions and informal meetings.
- (g) Participation in selected Camp Activities.
- (h) Sight seeing and shopping in Delhi.

### **Trg Dte**

64. Training Directorate (YEP) will handle all aspects of visit of Foreign Cadets except that Adm Dte will be responsible for accommodation, messing, allied amenities, transport and provision of souvenirs/ mementoes.
65. JD Trg (YEP) will be OIC Foreign Cadets and will be responsible to DDG (Trg) for smooth conduct of visit. He will be assisted by a LO Foreign Cadets (Male Officer) and a GCI from one of the Dtes.

### **Division of Responsibility**

66. **Trg Dte (YEP)**
- (a) And Adm and Joining Instructions to invited cadets.
  - (b) Obtain approval of DG as to number and type of presentation items to be provisioned and inform Adm Dte for procurement.
  - (c) Inform Adm Dte of number of Boys and Girls (country-wise) invited for arranging acommodation beddings, messing and transport.
  - (d) Inform Defence Attache in countries concerned and in India.
  - (e) Approach UP & Raj Dtes for organising visit to Agra and Jaipur.
  - (f) In consultation with RD Cell prepare detailed tentative programme for full duration of stay in India.
  - (h) Supervise conduct of programme.
  - (g) Provide/detail transport for cadets/LO.

### **Lgs Dte**

67. (a) Make provision for accommoaton (incl bathroom facilities and bedding), furniture, messing and transport in consultation with Trg YEP
- (b) Arrange transport for conducting staff.
  - (c) Procure presentation items as intimated by Trg YEP.
  - (d) Arrange services of sweeper and dhobi.
  - (e) Include requirement of furniture in contract
  - (f) Arrange a qualified catering JCO.

### **P&F Dte.**

68. Arrange passes in appropriate enclosure for Beating of Retreat & RD Parade. Dir Coord will arrange for passes for PM's Rally, Cultural Show, and Horse Show.

### **Camp Commandant**

69. (a) Set up Foreign Cadets area.
- (b) Provide requisite tentage, furniture, cooking utensils, crockery, cutley, commodes and other requirements.

- (c) Earmark seats for Foreign Cadets in all Camp functions/ events during period of visit.
- (d) Provide Indian Cadets and additional staff when required per programme for interaction with Indian Cadets.
- (e) Ensure Security of Foreign Cadets area and prevent entry of personnel not required for specific duty.
- (f) Supply News Papers and Magazines.
- (g) Detail a waiter and a Dhobi for the foreign cadets.
- (h) Detail the permanent cooks of the DG NCC Officers Mess and NCO's Mess for the Foreign Cadets.

### **Conducting Staff**

70. The following conducting staff will be detailed for making preparations, efficient conduct of programme, administration and escorting of foreign cadets during their stay in India.

- (a) LO Foreign Cadets Major or equivalent (Male Officer).
- (b) Lady LO (GCI).
- (c) Camp Comdt
  - (i) Two JCOs and Two NCOs (One JCO from unit/Dte of A Male LO Foreign Cadets).
  - (ii) Four Lascars out of Camp Lascars.
  - (iii) One Cook (who can prepare western meals, one helper, two sweepers and one dhobi).
  - (iv) One catering qualified JCO.

### **Duties of Conducting Staff**

71. Above conducting staff will function as a team under LO Foreign Cadets. DDG (Training) through DD Trg (YEC) will oversee their functioning. Administration aspect will, however, be overseen by DDG (Lgs) through the Camp Comdt. Expenditure on administration and messing etc will not, however, exceed allotted budget which will be controlled by DD Trg (YEC). Detailed duties of Officers/GCI are listed at **Appendix D**.

## PROCEDURE AND LAY OUT OF GUARD OF HONOUR

### Layout

1. The Guard of Honour will be formed up in three divisions when all the three services/wings are participating. It will be in two ranks with a distance of four paces between the front and the rear ranks and will be dressed at intervals of 24 inches. The distance between each division, will be three paces. As far as possible, the Guard of Honour, when formed up, will face the direction from which the personage for whom it is mounted is to arrive, will be sized and equalised as for a company.
2. The position of NCC Officers/UOs and NCOs in an inter-Service Guard of Honour will be as follows:-
  - (a) Commander. In the centre of the Guard of Honour and eight paces from the front rank.
  - (b) Cadets Commanding Division. The Cadet Commander of the Central division will be in the centre of his division and two paces from the front rank. Flank division commanders will be two paces in front of the second file from the Right and Left of their respective divisions.
  - (c) Right/Left Markers/Guards. The Senior NCO of the service concerned will be the Right guide and the Junior will be Left guide of his respective Division.
3. The Military band will form up on behind the Guard of Honour, in front of the Motivation Hall.
4. There will always be two ADC's, who will stand on either side of the dais, two paces to the right and left of the front edge of it.
5. The DG NCC will, after conducting the VIP to the dais, position himself to the left and slight rear of the VIP on the dais.
6. NCC Flag will be on the left and one foot lower than the pole of National Flag. National Salute will be presented to all Civilian Dignitaries while General salute will be presented to top service Chiefs.
7. When the VIP has mounted the dais and is in a position to receive the salute, the Guard of Honour will give the salute (National/ General), the band playing the appropriate salute. The DG will NOT salute, when either the National or General salute is given to the VIP.
8. After paying the appropriate compliments to persons for whom it is mounted, the Guard will be brought to BAZU SHASHTRA (Order Arms).

### Inspection

9. The procedure for inspection will be as follows:
  - (a) The Guard Commander will march forward and report to the VIP. The report will be in HINDI as follows: "NCC Samman guard nireekshan ke lie hazir hai Shriman."
  - (b) The Guard Commander, taking his position on the VIP's Right & DG NCC on Left, will conduct him to the band in "Quick March." On reaching the right hand man/cadet of the Guard, the Guard Commander will walk and NOT do the slow march, but the toes of the boots will be kept low. He will not swing arms during the inspection.

- (c) ADC's will precede the VIP during the inspection. They will on such occasion, do the slow march during the inspection.
- (d) As soon as the VIP passes the Left hand man/cadet of the band, the Bandmaster will turn-about, get the band ready and start playing. Taking the time from the first beat of the drum, every NCC Officer and Cadet of Guard will turn his head and eyes towards the VIP, i.e. they will look at him. As the VIP moves on the NCC officers and cadets will also move "their heads and eyes, looking at him all the time. If the VIP stops during inspection, the movement of heads will also stop.
- (e) The band will stop playing as soon as the VIP has finished the inspection and the Guard, taking the time from the last tune of the music, will turn their heads and eyes to the front.
- (g) Only the front rank of the Guard will be inspected. The VIP will move in front of the officers and he will inspect the' Guard from a distance of 3-4 paces from the front rank.
- (h) When the VIP has reached the dias, the Guard.Commander will salute the VIP. The Guard Commander must be prepared to shake hands with the VIP, should the latter offer to do so.

### **Marching of the Guard**

10. The Guard Commander will return to his post, and after the VIP has proceeded some distance away from the Guard of Honour, he may then stand the Guard at ease (Vishram). The Guard will, however, not march off or 'Stand Easy' (Aram se) till the VIP, for whom it is mounted, has left the place of reception. In case of RD Camp inaugural function VIP will be escorted back to the saluting dais for remaining ceremonies. Guard will only march off after the VIP has finished the round of Flag Areas and entered Photo Exhibition Tent.



## PROGRAMME OF NCC HORSE SHOW AND BAND DISPLAY

- |    |                 |   |   |
|----|-----------------|---|---|
| 1. | 1445 - 1455 hrs | Arrival of Guests.                      | <p>(a) Mounted escorts in Ceremonial Dress to take up position at the entrance.</p> <p>(b) Reception, seating and Ushering arrangements under DDG (Trg) assisted by JD (Coord).</p> <p>(c) Commentators to read out brief on NCC Horse Show and Role of R&amp;V Units in NCC (OIC R&amp;V to gust up draft brief to RD Cell by 09 Jan).</p> |
| 2. | 1500 hrs        | Arrival of Chief Guest (COAS)           | <p>(a) Fanfare.</p> <p>(b) To be received by DG and escorted to marked seats through 16 Welcome Girls attired in traditional dresses lined up on both sides of the passage.</p>   |
| 3. | 1502-1510 hrs   | Mounted Ride Past<br>by R&V NCC Cadets, | <p>(a) DG escorts Chief Guest to the Saluting Dais.</p> <p>(b) Maximum horses to participate. Riders will be in authorised Hiding Kit.</p> <p>(c) Services and NCC Cadets Bands to also march past.</p> <p>(d) Commentator to give running commentary. (Background material to be provided by OIC R&amp;V Det).</p>                         |
| 4. | 1510 -1533 hrs  | Show Jumping by Cadets.                 | Horse-Same<br>Riders-Change   |
| 5. | 1533 - 1540 hrs | band display by NCC Girls Band.         |   |
| 6. | 1540 - 1548 hrs | Show Jumping by RVC Riders.             |   |
| 7. | 1548 - 1556 hrs | Band Display by NCC Boys Band           | Jumps to be removed.  |
| 8. | 1556 - 1616 hrs | Tent Pegging (Open) Competition         | <p>(a) Dr. Roop Jyoti Sharma Memorial Trophy for Best Tent Pegger (Open).</p> <p>(b) Band Master of Service Band to co-ordinate show jumping, trick riding and Tent Pegging.</p>  |
| 9. | 1626 - 1640 hrs | Prize distribution.                     | Table orderly cadets will carry the prizes OIC R & V assisted by JD (Trg-A) to organise.  |

- |     |                 |                             |  |
|-----|-----------------|-----------------------------|--|
| 10. | 1640 - 1645 hrs | Address by the Chief Guest. |  |
| 11. | 1645 - 1700 hrs | Tea and Refreshment.        | <p>(a) Separate tea enclosure will be established for Guests and Officers by DDG (P&amp;F).</p> <p>(b) Camp PI Staff, Civ staff, GCIs and cadets including R&amp;V and NCC Bands Cadets to be issued sweets packets earlier by the Camp under arrangements of Camp Comdt.</p> <p>(c) Separate tea arrangements will be made for Senrice Band under arrangements oi Camp Comdt.</p> <p>(d) Prize winners to have to in guest enclosure. Mounted escorts to be in position till Guests depart.</p> |
| 12. | 1700 hrs        | Guests Depart.              | Mounted escorts to be in position till Guests depart.  |

## Notes:-

1. Dy DG (Trg) will be overall incharge of the function including Band display.
2. Function will be held in Harbaksh Stadium in Delhi Cantt. Camp Comdt will organise its cleaning and preparation.
3. All Camp Staff and cadets except those required for Camp security and on essential duties will attend.
4. Delhi Dte will invite 500 students from local schools to witness the show.
5. Officers, JCOs ORs anf families of local Army, Navy and Air Force Units will be invited to witness the show by JD Coord. Officers of RVC Dte, President's Body Guard, 61 CAV, 48 Mil Vet Hosp, PBG Vet will also be invited with their families.
6. Camp Commandant will arrange to shift fumiture, flags, storeslequipment and provide manpower from the Camp for arranging the function. Dy DG (T rg) will hold co-ordinating conference at the Harbaksh Stadium at 1415 hrs on 16 Jan. JD (Adm-A), JD (Coord), Secy RDC, Camp Comdt, Under Study Camp Comdt, Dy Camp Comdt, Adjt, JD (T rg-A) (OIC Prizes), OsC Boys and Girls will attend. OIC R&V will arrange this conference.
7. Prize distribution will be rehearsed from 14 Jan to 16 Jan.

**SUMMARY OF THE PRIZES REQUIRED FOR RDC**

<b>Srl. No.</b>	<b>Prizes</b>	<b>Qty</b>
1.	Banner	1
2.	Mini Banner	1
3.	Trophies	49
4.	Pure Silver Medals	6
5.	Gold Plated Medals	163
6.	Silver Plated Medals	157
7.	Bronze Plated Medals	151
8.	Dish	35
9.	Bowls	17
10.	Special Batton	8
11.	Normal Batton	2
12.	Mementoes	71
13.	Cup 6"	4
14.	Cup 8"	2

**RD BANNER COMPETITION DURING COCs**

<b>Sl.No.</b>	<b>Event</b>	<b>CPM</b>	<b>SPM</b>	<b>BPM</b>	<b>Trophy</b>
<b>BLC Boys</b>					
1.	Shooting JD	2	2	2	1
2.	Shooting SD	3	3	3	1
3.	Pt to Pt March	6	6	6	1
4.	Obstacle Course	6	6	6	1
5.	Advance Shooting	1	1	1	1
<b>BLC Girls</b>					
6.	First Aid & Home Nursing	1	1	1	1
7.	Signals	1	1	1	1
8.	Firing SW	2	2	2	1
9.	Firing JW	2	2	2	1
<b>Neu Sena Camp</b>					
10.	Sailing	3	3	3	1 (Rolling)
11.	Boat Pulling	8	8	8	1 (Rolling)
<b>Vayu Sena Camp</b>					
12.	Best Glider Pilot (Boys)	1	1	1	1
13.	Best Glider Pilot (Girls)	1	1	1	1
14.	Inter Dte Skeet Shooting	1	1	1	1
15.	Towline Glider	2	2	2	-
16.	Free Flight Power duration	2	2	2	-
17.	Control Line Speed	2	2	2	-
18.	Static Model Pt I	2	2	2	-

**REPUBLIC DAY CAMP PRIZES**

Sl. No.	Event	Banner	Mini Banner	Trophy	PSM	Special Batton
1	Overall Championship Dte	1	1	1	-	-
2	Runner Up Dte	-	-	1	-	-
3.	Best Dte Army Wing	-	-	1	-	-
4.	Best Dte Air Wing	-	-	1	-	-
5.	Best Dte Naval Wing	-	-	1	-	-
6.	Best Dte Girl's Wing	-	-	1	-	-
7.	Best Cadet SD Army	-	-	1	1	1
8.	Best Cadet SD Air	-	-	1	1	1
9.	Best Cadet SD Navy	-	-	1	1	1
10.	Best Cadet SW Army	-	-	1	1	1
11.	Best Cadet SW Navy	-	-	1	1	1
12.	Best Cadet SW Air	-	-	1	1	1
13.	Best Cadet JD Boys	-	-	1	1	1
14.	Best Cadet JW Girls	-	-	1	1	1
15.	Line Area Best Dte	-	-	1	-	-
16.	Flag Area Best Dte	-	-	1	-	-
17.	Best Dte Cultural Activities	-	-	1	-	-
18.	Best Dte in Guard of Honour and RD Contingent	-	-	1	-	-
19.	National integration	-	-	1	-	-
20.	Best Guard Commander Guard of Honour PM's Rally	-	-	1	-	-
				+1GPM		

Sl. No.	Event	GPM	SPM	BPM	Normal Batton
1.	RDP Contingent Cdrs	-	-	-	2
2.	IInd Best JW Girl Cdt	-	-	-	-
3.	IIIrd Best JW Girl Cdt	1	1	-	-
4.	IInd Best SW Girl Cdt	1	-	-	-
5.	IIIrd Best SW Girl Cdt	-	1	-	-
6.	IInd Best SD Army Cdt	1	-	-	-
7.	IIIrd Best SD Army Cdt	-	1	-	-
8.	IInd Best SD Naval Cdt	1	-	-	-
9.	IIIrd Best SD Naval Cdt	-	1	-	-
10.	IInd Best SD Air Cdt	1	-	-	-
11.	IIIrd Best SD Air Cdt	-	1	-	-
12.	IInd Best JD Cadet	1	-	-	-
13.	IIIrd Best JD Cadet	-	1	-	-
14.	Ship Model Powered	2	2	2	-
15.	Ship Model (R/C)	2	2	2	-

16.	Glider Model (R/C)	2	2	2	-
17.	Radio Control Power Model	2	2	2	-
18.	Static Aeromodelling Pt II	2	2	2	-
19.	Control Line Aerobatics	2	2	2	-
20.	Sole Song	1	1	1	-
21.	Folk Dance	20	20	20	-
22.	Orchestra	20	20	20	-
23.	Group Song	20	20	20	-
24.	Sole Dance	1	1	1	-
25.	Sailing Model	2	2	2	-
26.	Open Model	2	2	2	-
27.	Overall Static Model (Pt I&II)	2	2	2	-

Sl. No.	Event	Trophy	GPM	Dish	Bowl	Cup 6"	Mementoes
28.	Announcer	-	-	-	6	-	-
29.	Cadet Reading vote of thanks	-	-	9	-	-	-
30.	Prize distribution cadets	-	-	-	8	-	-
31.	Band Trainer/Unit	-	-	-	-	2	2
32.	Service Band, Band Master Unit	-	-	-	-	2	2
33.	Outstanding Staff	-	-	-	-	-	35 or more
34.	Momentoes for VIPs	-	-	-	-	-	12
35.	Partade Commander						
	Guard of Honour						
	(a) Vice President Inauguration	-	1	-	-	-	-
	(b) RM's Visit	-	1	-	-	-	-
	(c) Visit of 3 Service Chieives	-	3	-	-	-	-
36.	Inter Dte Drill Competition	1	-	-	-	-	-
37.	Inter Dte Drill Competition	1	-	-	-	-	-
38.	Best Dte in Social Service	1	-	-	-	-	-
39.	Best Dte in Aeromodelling	1	-	-	-	-	-
40.	Best Dte in Shipmodelling	1	-	-	-	-	-
41.	Best Sqn in Flyin	1	-	-	-	-	-
42.	Best Sqn in Gliding	1	-	-	-	-	-
43.	Best Radio Control Aeromodeller	1	-	-	-	-	-

Sl No.	Event	Trophy	GPM	SPM	BPM	Dish	Cup 8"	Bowl
44.	NCC Run	1	4	4	4	-	-	-
45.	Best Dte in Naval Wing Competition	1	-	-	-	-	-	-
46.	Most enterprising Naval Unit	1	-	-	-	-	-	-
47.	Best Dte in Skeet Shooting	1	-	-	-	-	-	-

48.	Best Glider Pilot	-	-	-	-	-	-	-
49.	Best Sqn in innovative Gliding	1	-	-	-	-	-	-
50.	Horse Show	4	14	14	14	26	2	3

**YEP**

51.	Grouping for Boys & Girls	-	2	2	2	-	-	-
52.	Application Boys & Girls	-	2	2	2	-	-	-
53.	Overall Best Firor Boys & Girls	-	2	2	2	-	-	-
54.	Quiz Competition	-	1	1	1	-	-	-

**COCS RD Banner - Competitions**

Sl.No.	Event	GPM	SPM	BPM	Trophy
--------	-------	-----	-----	-----	--------

**BLC Boys**

1.	Shooting JD	2	2	2	1
2.	Shooting SD	3	3	3	1
4.	Pt to Pt March	6	6	6	1
5.	Obstacle Course	6	6	6	1
6.	Advance Shooting	1	1	1	1

**BLC Girls**

6.	FAHN	1	1	1	1
7.	Signals	1	1	1	1
8.	Firing SW	2	2	2	1
9.	Firing JW	2	2	2	1

**Nau Sena Camp**

10.	Sailing	3	3	3	1 (Rolling)
11.	Boat Pulling	8	8	8	1 (Rolling)

**Vayu Sena Camp**

12.	Best Glider Pilot (BOYS)	1	1	1	1
13.	Best Glider Pilot (Girls)	1	1	1	1
14.	Inter Dte Sheet Shooting	1	1	1	1
15.	Towline Glider	2	2	2	-
16.	Free Flight Power Duration	2	2	2	-
17.	Control Line Speed	2	2	2	-
18.	Static Model Pt	2	2	2	-

**DUTIES OF OFFICER INCHARGE PRIZES**

1. The Director (Training) will be the OIC Prizes.
2. He will work out the requirement of various types of items for prizes in consultation with Secy RDC and "alter obtaining approval of DG write to Lgs Dte for procurement action.

3. On issue of Camp Programme by Secy RDC he will work out the presentation schedule. List of trophies and prizes to be distributed on various occasions are given at Appendix 'G'.
4. Oversee collection of trophies and prizes by Prize Distribution Officer from DD Lgs (B) and arrangements made for their safe custody and packing.
5. Brief Prizes Team on procedure and drill to be followed at various prize distribution ceremonies and supervise their rehearsals under Prize Distribution Officer.
6. Liaise with OIC Competition so that result of competitions are promptly communicated to Prize Distribution Officer as soon as result is approved by DG. In case of PM's Rally, three probables of Best Cadets of each category will be practised from 20 Jan onwards as result is declared barely two to three days before the Rally.
7. Organise practice of winners before each function and ensure smooth conduct of prize distribution ceremonies. He will position himself near the prizes table/prize carriers and pass on prizes in the correct serial to DG/Chief Guest, while the Prize Distribution Officer will marshal the recipients and send them in correct sequence, when their name is called out.
8. At the end of RD Camp check record of issue of trophies/prizes and ensure return of balance items to DD Lgs (B) on a voucher.
9. Efficiently organise Prize Distribution Ceremony at the PM's Rally. For this, particulars of trophy carriers and winners will be submitted to Dir Coord for security clearance. Special attention will be paid to correct drill/procedure by the Nishan Toli of new old Champion Dtes.

#### **PRIZE DISTRIBUTION OFFICER**

1. He will be a Major or Equivalent.
2. Take over polished Trophies and Prizes from DD Lgs (B)/DG NCC on proper voucher and arrange their safe custody and accounting. All transactions will be on loan vouchers.
3. Organise gift packing of items.
4. Select cadet helpers including table drill cadets (JD Cadets) out of non-participants of RD Parades, Cultural Show and confirm their availability from Camp Comdt and practice them.
5. Collect list of Prize Winners from OIC competition and inform the Cadets concerned through Contingent Commanders and Adjutant. Also practice recipients in drill for receiving prizes before the function.
6. Arrange Trophies/Prizes on the tables in the desired sequence and marshal the recipients as per sequence in the announcers List.
7. Properly account for all prizes and trophies. For individual prizes he will obtain signatures of recipients and get the same notified in Camp Routine Orders. For trophies he will obtain signature on IV/RV of the Contingent Commander.
8. Apprise OIC Prizes of any prizes not distributed as per schedule and get the alternate date fixed.
9. Collect Merit Certificates from Trg (Dte) and organise their issue to recipients along with the individual prizes on each distribution ceremony.

### DETAILED DUTIES OF CONDUCTING CAMP STAFF FOR FOREIGN CADETS

1. Study previous year's reports, feed back and suggestion. Also peruse correspondence with Foreign Missions & MOD.
2. Study programme prepared by Trg YEC and work out detailed timings and implement the same.
3. Collect amount of allotted budget, get utilization plan approved by DG (Trg).
4. Prepare foreign cadets area and get it inspected by Dy DG (Trg) four days before arrival of foreign Cadets & by Addl DG two days before their arrival. A JCO will be detailed to draw tentage, furniture and stores.
5. Study tentative programme for foreign cadets issued by Training (YEC) in conjunction with the camp programme issued by RD Cell. Approach Dy DG (Trg) and Secy RDC in case clashing with some other event and finalise the programme.
6. Prepare and put up planned utilization of allotted budget under various heads to Dy DG (Trg).
7. Meet General Manager Delhi Airport and Customs Commissioner and organise a reception counter at the International Arrival Lounge.
8. Arrange reservation for return journey as per departure programmes.
9. Contact and visit Embassies/High Commissions and finalise programme for Foreign Cadets visit to their respective Embassies High Commissions. MI Dte will be kept informed by Training YEC.
10. Check readiness of the accomodation and allied facilities.
11. Check the menu in consultation with GCI Foreign Cadets and ensure that it caters for the meals being taken outside the RD Camp.
12. Prepare detailed requirements of transport and submit it to Dy DG (Trg) through DD Trg (YEC).
13. Receive the Foreign Cadets from the Airport. GCI will accompany him whenever the contingent includes girl cadets also.
14. Get three copies of Bio-data Cards completed in respect of each cadet immediately on arrival. These will be submitted to Ministry of Defence and DG at least 24 hrs before meeting with any VIP.
15. Accompany the Foreign Cadets for visits to their respective Embassies/High Commissions and for courtsey calls on high dignitaries, sight seeing and shopping.
16. Conduct discussions and other programme as per training programme.
17. Conduct the Educational/Sight Seeing tour to Agra, Ajmer and Jaipur. He will ensure proper arrangement for transport, messing and accommodation. GCI will accompany and assist him. Some saving in the messing during the period of stay at the Camp will have to be affected in order to cater for the extra expenditure involved in messing during the tour.



18. Maintain daily accounts of the entire expenditure.
19. Arrange dispersal and see off the cadets.
20. Close Accounts Books, get the accounts audited by a Board of Officers at the Dte Gen NCC & submit it to CDA (HQ).

#### **Lady LO - Lady Officer or a GCI**

21. Get the girls living accommodation ready in time. She will look into special needs of the girls.
22. Prepare detailed meals schedule and menu for each meal in detail in consultation with the OIC and LO. When in the Camp, the food cooked for Indian cadets may be procured on payment from the cadets cook house. It must be supplemented with non spicy Western type of dishes. She must ensure that enough of non vegetarian dishes are served. A separate cook house will be set up for which a suitable cook may be employed.
23. Assist in reception and dispersal of Foreign Cadets.
24. Assist in conduct of the programme issued by Trg YEC. Also accompany and assist in local shopping when detailed.
25. Ensure proper adm and security arrangements in girls living accommodation. She will stay in a separate tent in close vicinity.
26. Accompany and assist the OIC in conduct of Educational/Sight Seeing tour to Agra, Ajmer and Jaipur.
27. Carry out any other duties assigned by the OIC/LO in connection with foreign Cadets programme.

#### **SELECTION OF CADETS FOR THE YOUTH EXCHANGE PROGRAMME**

28. The selection of cadets for various Youth Exchange Programmes and visit of NCC Delegations abroad is carried out during the RD Camp each year. JD Trg (YEC) will issue the Dte-wise vacancies indicating the number of cadets to be sponsored by each Dte for the above purpose and also lay down the eligibility conditions for the above. These cadets are considered an integral part of the Dte Contingent under the general vacancies of SD & SW Cadets and participate in the contingent events and other competitions as per competition rules. They are, therefore, within the overall allotted vacancies of the Dtes. Only SD and SW cadets are eligible.
29. Policy instructions on the subject are to be issued by Trg YEC.

#### **Screening and Selection**

30. Selection of Cadets for the above purpose is carried out in the following two phases:-
  - (a) Initial screening.
  - (b) Final selection by a Board of Officers consisting of Addl DG and 2 Dy DsG NCC of DG NCC and final interview by the Director General NCC.
31. For written test the cadets take the same test as those for Best Cadet Competitors.
32. The screening/selection is carried out under the supervision of the Dy DG (Trg). However, Dy DG (MS) will issue the formal composition of Board who will follow timings indicated in the Camp Programme preferably in the evenings, when the cadets are free from other competitions and Camp activities. This selection has no bearing on Inter Dte Competitions.
33. Dy DG (Trg) will prepare the final list of selected cadets in the order of merit and get approval of the DG and further carry out actual detailment/nomination of cadets on various delegations with the approval of the DG.

**STANDING INSTRUCTIONS****ANNUAL NCC REPUBLIC DAY CAMP AT DELHI CANTT****INTER DIRECTORATE REPUBLIC DAY BANNER COMPETITIONS****VOLUME II****INDEX OF RULES**

<b><u>Ser No</u></b>	<b><u>Subject</u></b>	<b><u>Appendix</u></b>	<b><u>Annexure</u></b>	<b><u>Page</u></b>
1	<b>General</b>	-	-	148
2	<b>Inter Directorate Mandatory Condition and General Proficiency Achievement Competition</b>	<b>A</b>		158
	Attendance of Camps by Cadets		A1	159
	Remittance of Regimental Fund		A2	159
	Cadet Welfare Society Contribution		A3	160
	Utilisation of Cadet Welfare Society Scholarship		A4	160
	Deficiency of ANOs		A5	160
	Selection in Mountaineering Expedition		A6	162
	ACR - Regular and Whole Time Lady Officers		A7	162
	Enrolment of Cadets		A8	164
	Timely reporting of Officers, WTLO, ANO, PI Staff & GCI for Centrally Organised Camps and Courses		A9	164
	Logistic Check of Directorates		A10	165
	Management of Clothing		A11	166
	Management of Vehicles		A12	167
	MT Accident Assessment		A13	167
	Management of Equipment		A14	168
	Management of Land, Civil Works & Accommodation		A15	169
	Audit Objections and Observations		A16	169
	Out Standing Losses		A17	170
	Induction of Cadets into the Armed Forces as Officers & Soldiers		A18	170
3	<b>Inter Directorate Naval Wing Competitions at AINSC &amp; RDC</b>	<b>B</b>		173
	Most Enterprising Naval Unit Competition (MENU)		B1	177
	Documentation Procedures: Letter of Proceedings of Naval Training (LPNT)		B2	182
	Ship Modelling Competition at AINSC & RDC		B3	183
	Service Subjects Competition (Written Exam)		B4	188
	Seamanship (Practical Exam)		B5	189

<b>Ser No</b>	<b>Subject</b>	<b>Appendix</b>	<b>Annexure</b>	<b>Page</b>
	Boat Pulling Competition		B6	190
	Boat Rigging Competition		B7	196
	Shooting Competition		B8	197
	Drill Competition		B9	201
	Semaphore Competition		B10	204
	Best Cadet Competition		B11	205
	Line Area Competition		B12	207
	Health & Hygiene Competition		B13	208
	Sailing Regatta Competition		B14	209
4	<b>Inter Directorate Air Wing Competitions at AIVSC</b>	<b>C</b>		213
5	<b>Inter Directorate Army Wing Competitions (AITSC - Boys)</b>	<b>D</b>		221
	Obstacle Course Competition		D1	224
	Map Reading Competition		D2	226
	Line Area Competition		D3	227
	Health & Hygiene Competition		D4	230
	Judging Distance & Field Signal Competition		D5	
6	<b>Inter Directorate Army Wing Competitions (AITSC - Girls)</b>	<b>E</b>		233
	Health & Hygiene Competition		E1	235
	Line Area Competition		E2	236
	Map Reading Competition		E3	239
	Obstacle Course Competition		E4	240
	Judging Distance & Field Signal Competition		E5	241
7	<b>Inter Directorate Service Shooting Competition</b>	<b>F</b>		244
	Rules for SD Shooting Competition		F1	246
	Rules for SW, JW & JD Shooting Competition		F2	248
8	<b>Rules for Inter Directorate Sports Shooting Competition</b>	<b>G</b>		250
9	<b>Inter Directorate Line &amp; Flag Area Competition</b>	<b>H</b>		255
	Line Area Competition		H1	256
	Flag Area Competition		H2	262
10	<b>Rules for Guard of Honour and RD Parade on Rajpath Participation Competition</b>	<b>J</b>		265
11	<b>Inter Directorate National Integration Awareness</b>	<b>K</b>		272
12	<b>Inter Directorate March Past Competition during PM's Rally</b>	<b>L</b>		274
13	<b>Inter Directorate Cultural Competitions</b>	<b>M</b>		278

<b><u>Ser No</u></b>	<b><u>Subject</u></b>	<b><u>Appendix</u></b>	<b><u>Annexure</u></b>	<b><u>Page</u></b>
14	Best Cadet Competition and YEP Selection	N		283
15	Inter Directorate Discipline Competition	O		293
16	Inter Directorate Cultural Competition at NIC II	P		297
17	Inter Directorate R&V Equestrian Competitions (Non RD Banner event)	Q		301

**STANDING INSTRUCTIONS**  
**ANNUAL NCC REPUBLIC DAY CAMP AT DELHI CANTT**  
**INTER DIRECTORATE REPUBLIC DAY BANNER COMPETITIONS**  
**VOLUME II**

**GENERAL RULES**

**General**

1. Inter Directorate Republic Day (RD) Banner Competitions covering a wide spectrum of activities are conducted on annual basis, with an aim of generating healthy competitive spirit amongst NCC cadets and enhancing their training standards. Consolidation of the results thereof assists in determining the Champion Directorate, which is presented the PM Banner by the Prime Minister at the PM's NCC Rally held on 28 January every year.
2. These competitions are conducted during Annual NCC RD Camp (RDC) as well as during various 'Centrally Organised Camps'. Administrative instructions giving venue, duration and other relevant details for competitions conducted during such camps, are issued separately by DGNCC/Training (A) every year.

**List of Competitions**

3. The RD Banner Competitions are conducted in three parts as stated and tabulated below: -
  - (a) **Part I.** Assessment based partly on Reports & Returns relating to training & logistics, submitted during the year and partly on Naval Wing Training Reports regarding those events conducted prior to Nau Sainik Camp, which contribute towards evaluation of 'Most Enterprising Naval Unit (MENU)'.
  - (b) **Part II.** Assessment based on performance of Directorate Contingents during team events held in centrally organised camps like All India Thal Sainik (Boys/Girls), Nau Sainik & Vayu Sainik Camps and Sports Shooting.
  - (c) **Part III.** Assessment based on performance of Directorate during RDC both in 'contingent events' and 'individual/other events' held during RDC.

**PART I: COMPETITIONS BASED ON REPORTS & RETURNS**

<b><u>Ser No</u></b>	<b><u>Event</u></b>	<b><u>Points</u></b>		
		<b><u>Total</u></b>	<b><u>RD Banner</u></b>	
1	<b>Mandatory Conditions and General Proficiency Achievement Competition</b>			
	<b>Training Aspects</b>			
	Attendance at Camps by Cadets	150	30	
	Remittance of HQ DGNCC share of Regimental Fund	80		
	Cadet Welfare Society Contribution	80		
Utilisation of Scholarships Awarded by CWS	80			

<u>Ser No</u>	<u>Event</u>	<u>Points</u>	
		<u>Total</u>	<u>RD Banner</u>
	Deficiency of ANOs	100	
	Selection for Mountaineering Expedition	30	
	ACR Regular/Whole Time Lady Officers	50	
	Cadet Enrolment	100	10
	Timely Reporting of Officers, WTLOs, ANOs, PI Staff & GCIs for various Centrally organized Camps including RDC and various courses at NCC OTAs.	-	10
	<b>Total</b>	<b>670</b>	<b>50</b>
	<b>Logistics Aspects</b>		
	Logistics Check of Directorate by Board of Officers	100	15
	Management of Clothing	25	
	Management of Vehicles	25	
	Management of Equipment	25	
	Management of land, Civil Works & Accommodation	25	
	Audit Objections	15	
	Outstanding Loss Cases	15	
	<b>Total</b>	<b>230</b>	<b>15</b>
	<b>Induction of Cadets into Armed Forces as Officers &amp; Soldiers</b>	-	<b>35</b>
2	<b>Naval Training: Most Enterprising Naval Unit (MENU)</b>	<b>150</b>	<b>10</b>
3	<b>Documentary procedures: Letter of Proceedings on Naval Training (LPNT) (To be assessed by Trg Dte)</b>	<b>100</b>	<b>05</b>
4	<b>Air Wing Incentivising (To assessed by Trg Dte)</b>	<b>100</b>	<b>30</b>
	<b>Total (Part I)</b>	<b>1250</b>	<b>145</b>

**PART II: COMPETITIONS HELD DURING CENTRALLY ORGANISED CAMPS**

<u>Ser No</u>	<u>Event</u>	<u>Points</u>	
		<u>Total</u>	<u>RD Banner</u>
5	<b>All India Nau Sainik Camp (AINSC), Sailing Regatta</b>		
	Service Exam (Written)	200	10
	Seamanship (Practical)	50	3
	Boat Pulling	200	10
	Boat Rigging	100	3
	Shooting / Firing	100	7
	Drill	100	7
	Semaphore/Communication	100	3
	Ship Modelling	200	7
	Best Cadets (SD & SW)	150	8
	Line Area	50	3
	Health & Hygiene	50	2
6	<b>Sailing Regatta</b>	<b>250</b>	<b>15</b>
	<b>Total</b>	<b>1550</b>	<b>78</b>

<u>Ser No</u>	<u>Event</u>	<u>Points</u>	
		<u>Total</u>	<u>RD Banner</u>
7	<b>All India Vayu Sainik Camp (AIVSC)</b>		
	Flying	1200	70
	Aero Modelling	650	
	.22 Shooting	200	
	Skeet Shooting	200	
	Drill	200	
	Line Area	100	
	Health & Hygiene	100	
	<b>Total</b>	<b>2650</b>	<b>70</b>
8	<b>All India Thal Sainik Camp (AITSC Boys)</b>		
	Obstacle Course	75	50
	Map Reading Competition	75	
	Line Area & Tent Pitching Competition	40	
	Health & Hygiene	50	
	Judging distance and field signal competition	80	
	<b>Total</b>	<b>320</b>	<b>50</b>
9	<b>All India Thal Sainik Camp (AITSC Girls)</b>		
	Health & Hygiene	50	50
	Map Reading Competition	75	
	Line Area & Tent Pitching Competition	40	
	Obstacle Course	75	
	Judging distance & Field Signal Competition	80	
	<b>Total</b>	<b>320</b>	<b>50</b>
10	<b>Service Shooting Competition</b>		
	(i) SD	130	60
	(ii) SW	90	
	(iii) JD	90	
	(iv) JW	90	
	<b>Total</b>	<b>400</b>	<b>60</b>
11	<b>Sports Shooting</b>		
	Inter Directorate Shooting Competition	-	35
	AI GV Mavlankar Shooting Competition	-	10
	National Shooting Championship Competition	-	05
	<b>Total</b>	<b>-</b>	<b>50</b>
	<b>Total (Part II)</b>	<b>5240</b>	<b>358</b>

**PART III: COMPETITIONS HELD DURING RDC**

<b>Ser No</b>	<b>Event</b>	<b>Points</b>	
		<b>Total</b>	<b>RD Banner</b>
12	<b>Contingent Events held during RDC Line &amp; Flag Area Competition</b>		
	Line Area	220	30
	Flag Area Assessments	170	50
	<b>Total</b>	<b>390</b>	<b>80</b>
13	<b>Guard of Honour &amp; RD Parade Participation Competition</b>	<b>600</b>	<b>81</b>
14	<b>National Integration Awareness Competition</b>	<b>120</b>	<b>60</b>
15	<b>PM's Rally March Past Competition</b>	<b>600</b>	<b>144</b>
16	<b>Cultural Competition</b>		
	Group Song	100	70
	Group Dance	150	
	Ballet/Dance	100	
	<b>Total</b>	<b>350</b>	<b>70</b>
17	<b>BC Competition and YEP Selection</b>		
	Written Test (GK)	50	50
	Written Test (SS)	100	
	Drill (150 for BC & 75 for YEP)	150	
	Firing	150	
	Personality and Communication Skills	300	
	DG Interview	100	
	Participation in RDC Events	50	
	<b>Total</b>	<b>900</b>	<b>50</b>
18	<b>Discipline Competition</b>	<b>740</b>	<b>85</b>
19	<b>Navy Modelling Competition</b>	<b>200</b>	<b>7</b>
20	<b>Cultural Competition at NIC II, Delhi</b>	<b>100</b>	<b>10</b>
	<b>Total (Part III)</b>	<b>4000</b>	<b>587</b>
	<b>GRAND TOTAL</b>	<b>10490</b>	<b>1090</b>

4. **Competitions Not Counted Towards RD Banner.**

- (a) All R & V Competitions Competition (**Appendix Q**).
- (b) Selection of cadets for YEP (**Appendix N**).

5. **General Conditions for Award of Points.**

- (a) Directorate scoring highest marks in aggregate is declared the winner of RD Banner Championship.
- (b) The Directorate that fails to field a team in any Competition will be awarded nil marks in that competition.
- (c) Due consideration will be given to Directorate exempted from particular.



- (d) Competition and their overall percentage will be computed on number of competitions in which such Directorates have participated.

### **Random Selection**

6. Random selection by draws taken by Officer-in-Charge (OIC) Competition will be carried out 48 hours prior to the competition to shortlist the participants for each competition except for Contingent/Team competitions like Guard of Honour & RD Parade Selection, Part-I of National Integration Awareness(Presentation), Line & Flag Area, Cultural, Best Cadet and PM's Rally March Past.

7. Directorates can, however, nominate 25% of total participants rounded off to the lower whole number in the following events: -

- (a) Obstacle Course & Map Reading.
- (b) Health & Hygiene.
- (c) Advance Shooting.
- (d) Shooting Competition Common to All Wings.

8. Instructions for random selection in respect of Air & Naval Wing Competitions are given in rules for respective competition.

9. This selection will be made from the entire nominal roll of the contingent participating in the camp. Any State Directorate which fails to field full team including the reserve will get penalty marks as follows: -

- (a) In case of shortfall in the Inherent penalty because the 'nominated - cadets' selected Contingent scores no marks after random selection against what that particular participant would have otherwise scored
- (b) In case of shortfall in the 05 Penalty points per shortfall 'reserves' - selected after random selection

### **Participation/ Exemptions**

10. Strength of Teams, and exemptions for each competition are given in the Rules at **Appendices 'A' to 'Q'**.

11. The following cadets will not take part in any Competition and will only take part in competitions as indicated against them:-

- (a) Band Cadets. Will not take part in any competition, other than Line Area & Discipline Competition.
- (b) R & V Cadets. Will only take part in R & V Competitions, Line Area & Discipline Competition.

### **General Provisions**

12. Following general rules will be followed for all RD Banner Competitions:

- (a) Participation is open only to cadets on enrolled strength of NCC Directorates.

- (b) A cadet will not attend RD Camp more than once. A Cadet who has attended a RD Camp as a JD/JW cadet may, however, attend one more RD Camp as a SD/SW cadet.
- (c) Cadets of NCC Bands may attend RD Camp more than once provided they remain on the enrolled strength of NCC.
- (d) Cadets of R&V Units can, however, attend maximum of two RD Camps in the same category.
- (e) A cadet may appear for Best Cadet competition as a JD/ JW & then later as SD/SW.
- (f) A cadet selected in Guard of Honour and Rajpath is not allowed to participate in any other event less Best Cadet & YEP Selection.
- (g) Cadets participating in NAIP or Cultural Competition are not allowed to participate in Guard of Honour or Rajpath.
- (h) For AITSC (Boys), AITSC (Girls) and Service Shooting Competition, the aim would be to have all participants participating in at least one of the competitions.
- (j) A cadet will not attend AINSC/AIVSC/AITSC more than once.
- (k) Cadets who have attended AINSC/AIVSC/AITSC may, however, attend RD Camp.
- (l) No cadet in 1st year training of respective Division/Wing are eligible to participate in AINSC/AIVSC/AITSC/RDC/COC.
- (m) Cadets who have already attended RD Camp are not allowed to participate in AINSC/AIVSC/AITSC.

### **Conduct of Competitions**

13. DDG (MS) of DGNCC is the ex-officio OIC of all RD Banner Competitions. DDG (MS) details Boards of Officer/Judges and is responsible to DG for ensuring that competitions are conducted and results compiled as per policy laid down in these Rules. Results of all competitions including those of Army/Naval/Air/Girls Wing are put up to the DG for approval.

14. Responsibility for detailing Boards of Officers/Judges for various competitions is asunder :-

- (a) **DDG (MS), HQ DGNCC.** Competitions for the RD Banner to be held at RDC.
- (b) **DDG (MS), HQ DGNCC.** Competitions for RD Banner to be held during following Centrally Organised Camps :-
  - (i) AI TSC (Boys).
  - (ii) AI TSC (Girls).
  - (iii) Service Shooting Competition.

(c) **ADG (B) in Consultation with DDG (MS), JD (Navy) and JD (Air).**

Competitions for RD Banner to be held at following Centrally Organised Camps and events thereof, which are held during RDC: -

- (i) All India Nau Sainik Camp (NSC).
- (ii) All India Vayu Sainik Camp (AIVSC).
- (iii) All India Sailing Regatta.

15. Judges are detailed a minimum of two months in advance keeping the leave plan of officers in mind so that officers so detailed, study the competition rules and make themselves fully conversant with rules and regulations laid down for such competitions, The judges so detailed will also have a copy of the rules of that particular event/competition.

16. Members of the Board will be briefed in detail by OIC Competitions prior to competitions and on the day of the competition as well. No officer posted to a NCC Directorate or to its Groups/Units is to be a Judge or member of the Board or assigned any responsibility for actual conduct of or for judging any competition or for compilation of results.

17. The Board of Officers will be composed entirely of officers of DGNCC except the following:

(a) **Health & Hygiene /Communications.** A medical officer and an officer from Signals may be detailed to supervise the 'Health &Hygiene' and 'Communications' components of competitions held during TSC Girls. At least one member from Training Directorate DGNCC, must be incorporated.

(b) **Cultural Competitions.** DDG MS will be responsible for detailing a panel of Judges for each event of Cultural Competition.

(c) **Air and Naval Competitions.** Officers of Indian Air Force and Indian Navy(other than those posted to any NCC Directorate/Group/Unit) may be detailed.

(d) DDG (MS) with the approval of the DG, will nominate a DDG from HQ DGNCC to act as observer during competitions to be held at each Centrally Organised Camps. DDG so nominated will give decisions on the spot on any objection/protest and declare the results before termination of camp. Declaration of the results may, however, be delegated to Presiding Officer of the Board.

18. Camp Commandant/Staff is responsible for making all arrangements and provision of equipment, facilities, infrastructure and staff for conduct of competitions as per directions of OIC competitions/Chief Judges of various competitions. As they neither Judge/conduct an event, nor compile/announce the results they should not sit/stand close to Judges during the competition/compilation of results.

### **Protests/Objections/Complaints**

19. All Protests/Objections/Complaints are to be lodged only in writing along with Rs 500/- (refundable only in case the complaint is substantiated), and handed over to Dir (MS), within 6 hours of the completion/closing of the competition. These will be referred to a jury composed as under: -

(a) **During RD Camp.**

- (i) DG NCC
- (ii) ADG (A) & ADG (B)

- (iii) OIC Competition: DDG (MS) (in attendance)
- (iv) Secretary RDC

(b) **During a Centrally Organised Camps.** DDG of DGNCC detailed to oversee the competitions will form a Jury. Decision of the Jury will be final and binding and no further appeal or representation will be entertained. Tendency to put up representations/protests on frivolous grounds will be curbed.

(c) Decision by Jury will be intimated at the earliest, verbally and in writing within 48 hours of lodging of the protest. This will endure continuance of competitions.

## 20. **Disqualification.**

(a) Any Directorate making accusation against another Directorate for using unfair means will be disqualified, if the accusation is not proved or substantiated.

(b) Any infringement of these rules will render Directorate Team liable to disqualification.

(c) Any Directorate providing fraudulent data for competitions will be liable to be disqualified for that competition.

(d) Discipline cases.

## 21. **Breaking of Tie.**

(a) When two or more directorates secure equal points, they will be granted the position that their points indicate.

(b) In case of a tie for the first position in the overall RD Championship Banner between two or more Directorates, the Banner will be awarded to the Directorate securing the highest aggregate among the Contingent Events. In case, tie still persists then the position of the concerned Directorates in the Line and Flag Area Competition will decide the issue.

(c) In case of tie for individual position for prizes during the shooting competitions, the tie will be broken as provided in the Rules for Shooting.

22. **Prizes/Trophies/Certificates.** The policy regarding award of prizes, trophies and merit certificates for the winners of various competitions of RD Banner will be as explained in succeeding Para. Names of recipients will be published in Camp Orders. Signature of all the recipients will be obtained and held for record. Trophies will be handed/taken over on vouchers.

23. **Competitions Held at Centrally Organised Camps.** Individual prizes, merit certificates and trophies will be distributed at a suitable function at the Camp itself. Organising Directorate will be responsible for collection of individual prizes, merit certificate and trophies from DGNCC (Training A) and issue to the Camp Commandant.

24. **Competitions Held During RD Camp.** Trophies and individual prizes along with the merit certificates for the following will be issued as indicated against each: -

(a) Equestrian Events - At the NCC Horse Show cum Band Display.

(b) Others - At one of the Cultural Shows/DG's Closing Address.

25. Merit Certificates will be issued only for Team and Individual Competitions counting towards RD Banner, except for cultural items for which no merit certificate will be issued. Any other merit certificate will be issued at the discretion of the DG.

26. **PM's Rally.** The following RD Banner Prizes will be awarded at the PM's Rally:-

- (a) Best Overall Directorate – Trophy & PM Banner (to be received by ADG/ DDG).
- (b) First Runners Up Directorate – Trophy.
- (d) Best Army SD Boy Cadet – Medal & Baton.
- (e) Best Navy SD Boy Cadet – Medal & Baton.
- (f) Best Air SD Boy Cadet – Medal & Baton.
- (f) Best Army SW Girl Cadet – Medal & Baton.
- (g) Best Navy SW Girl Cadet – Medal & Baton.
- (h) Best Air SW Girl Cadet – Medal & Baton.
- (i) Best JD Cadet - Medal & Baton.
- (k) Best JW Cadet – Medal & Baton.

### **Declaration of Results**

27. During RD Camp, a scoreboard will be put up near the Camp office on which results of RD Banner competitions will be marked by Assistant Camp Adjutant under the supervision of OIC Competitions after approval of results by the DG NCC. Contingent Commanders may ascertain their detailed scores from OIC Competitions individually. RD Cell will declare all results to Directorates on the basis of copy received from OIC Competitions.

### **Submission of Nominal Roll**

28. Directorates will submit the nominal roll of their teams, separately for each competition, including reserves, in triplicate to the Camp Commandant who will hand these over to Board of Officers conducting the competitions. These must be signed by the DDGNCC concerned or in his absence Director/JD. In case Camp Commandant of a Centrally Organised Camp does not receive nominal roll from any Directorate, he will call upon the senior most Officer/PI Staff/Cadet of that Directorate team, to do so. This will be deemed to be the official team of the Directorate.

### **Penalty Points**

29. Penalty points for various lapses & non-compliance of instructions will be awarded for various competitions as given out in the competition rules. Penalty points will also be awarded for lapses of discipline, turnout, non-participation by selected cadets in RD Parade/PM's Rally/Guard of Honour practices, non-compliance of instructions by Directorates and any other lapses, which adversely affect the conduct of the Camp.

30. Penalty points will be awarded by a Committee chaired by the ADG (B) with DDG(MS) and DDG (Training) as members. The Committee will be empowered to award penalty of upto 50 points depending on the seriousness of each lapse. For severe offences penalty of

more than 50 points, where necessary, may also be recommended by the Committee for approval of the DG.

31. Penalty points awarded to a Contingent after declaration of RD Banner Results will be carried forward to count towards the RD Banner Competition for next year.

### **Marking System**

32. The marking system for both Part-I and Part-II of the RD Banner Competitions will be on the percentages basis up to the second decimal place only, i.e., all Directorates will be awarded marks based on actual score. For example if Directorate 'A' scores 300 marks out of 500 in Drill Competition then these marks will be reduced out of 80 thus making 48. This system of marking will be followed for all other competitions. Finally if Directorate 'A' scores 50 out of 100 in Part-I and 500 points out of 750 points in Part -II, accordingly out of 100 the Directorate would have scored 73.333, which will be counted as 73.33 towards the overall position.

**Appendix A**  
**(Refers to Para 3 of General Rules)**

**INTER DIRECTORATE MANDATORY CONDITIONS AND  
GENERAL PROFICIENCY ACHIEVEMENT COMPETITION**

**General**

1. Inter Directorate Competition for the Mandatory Conditions and General Proficiency Achievements Competition (based on Reports & Returns) counting towards the RD Banner will be held as per the procedure laid down in the succeeding paragraphs. **The Competition contains 900 Marks and carries 100 points towards the RD Banner.** This competition will cover the period from 01 Dec to 30 Nov next year. All the returns pertaining to this competition will be submitted without fail by the dates indicated in their corresponding Annexure. The returns reaching HQ DGNCC at a date later than the specified date will be awarded zero points.

2. **List of Reports & Returns.** The list of 'reports & returns' and quantifiable training/Administrative/ Logistic activities of various Directorates, for this competition are given as under: -

<b><u>Ser No</u></b>	<b><u>Event</u></b>	<b><u>Points</u></b>	
		<b>Total</b>	<b>RD Banner</b>
(a)	Attendance at Camps by Cadets	150	30
(b)	Remittance of HQ DGNCC share of Regimental Fund	80	
(c)	Cadet Welfare Society Contribution	80	
(d)	Utilisation of Scholarships Awarded by CWS	80	
(e)	Deficiency of ANOs	100	
(f)	Selection for Mountaineering Expedition	30	
(g)	ACR Regular/Whole Time Lady Officers	50	
(h)	Cadet Enrolment	100	10
(j)	Timely Reporting of Officers, WTLOs, ANOs, PI Staff, GCIs and Cadets for various Centrally organized Camps including RDC and various courses at NCC OTAs.	-	10
(k)	Logistics Check of Directorate by Board of Officers	100	15
(l)	Management of Clothing	25	
(m)	Management of Vehicles	25	
(n)	Management of Equipment	25	
(o)	Management of Land, Civil Works & Accommodation	25	
(p)	Audit Objections	15	
(q)	Outstanding Loss Cases	15	
(r)	Induction of Cadets into Armed Forces as Officers & Soldiers	-	35
	<b>Total</b>	<b>900</b>	<b>100</b>

3. Modalities for points to be awarded towards each serial above have been elaborated in corresponding Annexure.

4. The report of the Inter Directorate Mandatory Conditions and General Proficiency Achievements Competition i.e. Annexure 1 to 18 duly signed by the State ADG/DDG, will be forwarded to concerned Directorates/Sections of HQ DGNCC (as stated in Para 5 below), latest by 15 Dec each year. Reports received after due date will not be considered for competition and zero points will be awarded to the affected Directorate.

5. **Allocation of Responsibilities.** Responsibilities of various Directorates/Sections of DGNCC to compile the reports for competitions are as under: -

- (a) Attendance of camp by cadets - Training 'A'.
- (b) Remittance of DG's share of Regimental Fund. - MS Directorate.
- (c) Cadet Welfare Society Contribution - P&F Directorate.
- (d) Utilisation of Scholarship by CWS - P&F Directorate.
- (e) Deficiency of ANOs - DGNCC/MS (D).
- (f) Selection of Cadets for Mountaineering Expedition - Training (B)
- (g) ACR Regular / Whole Time NCC Officers – MS Directorate (MS (C))
- (h) Timely Reporting of Officers, WTLOs, ANOs, PI Staff, GCIs and Cadets for various centrally organized Camps including RDC and various courses at NCC OTAs - MS Directorate (MS (A)).
- (j) Cadets Enrolment – P & C Directorate (Planning Sec)
- (k) Logistic Aspects (Annexure 10 to 16) - Logistics Directorate
- (l) Induction of Cadets into Armed Forces as Officers & Soldiers (Annexure 17) - P & F Directorate.

6. **Award of Points.** The award of RD Banner points will be as under: -

$$\text{RD Banner Points} = \frac{\text{Points obtained out of 900} \times 100}{900}$$

**Annexure A1**

**ATTENDANCE OF CAMPS BY CADETS**

<u>Directorate</u>	<u>Vacancies Allotted</u>	<u>Actual Attendance</u>	<u>Score</u>
	A	B	(B x 100)/ A

**Annexure A2**

**REMITTANCE OF HQ DGNCC SHARE OF REGIMENTAL FUND**

<u>Directorate</u>	<u>Date on which Sent</u>	<u>Amount of Remittance</u>

1. Directorate remitting full amount by 30 Nov will be allocated full points.



2. J & K and NER Directorate are allowed to remit till 30 Dec.
3. **Penalty.** After 30 Nov, penalty will be awarded at the rate of 10 points per each delayed working day delayed, up to maximum Five working days. Beyond which, zero points will be awarded.

**Annexure A3****CADET WELFARE SOCIETY CONTRIBUTION**

<u>Directorate</u>	<u>Date on which Sent</u>	<u>Amount of Remittance</u>

1. Directorate remitting full amount by 30 Nov will be allocated full points.
2. **Penalty.** After 30 Nov, penalty will be awarded at the rate of 10 points per each delayed working day delayed, up to maximum Five working days. Beyond which, zero points will be awarded.

**Annexure A4****UTILISATION OF CADET WELFARE SOCIETY SCHOLARSHIPS AWARDS**

<u>Directorate</u>	<u>Total Number of Vacancies Utilisation</u>	<u>Total number of Scholarship Awarded</u>	<u>Percentage Utilisation</u>
	A	B	(B x 100)/ A

**Annexure A5****DEFICIENCY OF ASSOCIATED NCC OFFICERS (ANO)**

1. **Aim.** To make up the deficiencies in the cadre of part-time ANOs.
2. **Method of Assessment.**
- (a) A report on the 'authorised' and 'posted strength' of ANOs will be rendered by all NCC Directorates, on 10th of April, 10th July, 10th October and 10th January (covering period upto last day of preceding month), as per following format: -

<u>Group HQ</u>	<u>Enrolled Cadets</u>	<u>Divisions/ Wings</u>	<u>ANO in Army Division</u>				
			<u>Auth</u>	<u>Held</u>	<u>Defi</u>	<u>Caretaker</u>	<u>On Sick Leave</u>
A	B	C					
		SD					
		SW					

		JD					
		JW					

<u>ANO in Air Division</u>					<u>ANO in Naval Division</u>				
E					F				
Auth	Held	Defi	Caretaker	On Sick Leave	Auth	Held	Defi	Caretaker	On Sick Leave

<u>ANO in Girls Division</u>					<u>Total</u>				
G					H				
Auth	Held	Defi	Caretaker	On Sick Leave	Auth	Held	Defi	Caretaker	On Sick Leave

(b) The Borne Strength percentage of ANOs of each Directorate will be computed from the report submitted on 10th Oct by applying the following formula: -

$$\text{Borne Strength Percentage} = \frac{\text{Posted Strength \& Caretakers} \times 100}{\text{Authorised Strength}}$$

(c) In addition to report or input being fwd to P&C Directorate by various state Directorates regarding allotment/withdrawal of institutions from NCC units, one copy be endorsed to MS (D) branch of MS Directorate for info only.

(d) For the purpose of competition, report of third quarter i.e. 10th Oct every year be considered, thereby giving adequate time for compilation, authentication and cross checking. The return of last quarter will be taken into consideration for following year competition.

(e) To ensure timely submission of this report, a penalty of 0.5 marks for each day of delay, will be awarded to the defaulting Directorate.

(f) For the purpose of report and return, appointment of an ANO will be considered as completed only on approval of the Board Proceedings pertaining to it by the DGNCC and not merely on submission of the documents. Appointment of 'Caretakers', however, will be considered for compensating the shortfall in holding of ANOs.

3. The points obtained by each Directorate out of 100 (Maximum points), will be computed as under :-

$$\text{Points Obtained} = \text{Borne strength percentage of ANOs} \times 100$$

4. The report covering the period from 01 October to 30 September for the preceding year will be forwarded to reach DGNCC/MS (D) latest by 15 October every year.

## Annexure A6

### SELECTION FOR MOUNTAINEERING EXPEDITIONS

1. **Aim.** To encourage NCC Cadets for participating in various Mountaineering Expeditions and to assess the performance of the Directorates, in achieving the same.
2. **Eligibility.** As per criteria, issued from time to time.
3. **Judging.** The evaluation will be undertaken at HQ DGNCC based on the participation of NCC Cadets from respective State Directorates in these events/competitions. The details will be compiled by JD (Training) & JD (Adventure), at HQ DGNCC, and forwarded to Presiding Officer, latest by 20th December each year.
4. The compilation of data will be done together for Army, Navy and Air Wings of NCC and will be worked out as per following formula:-

$$\frac{\text{Total Number of cadets who actually participated in these events} \times 100}{\text{No of cadets who were nominated in the Directorate}}$$

5. **Weightage.** Based on the results as per Para 4 above, the Directorate with the highest score will be placed on top and one with the lowest score will be placed at the bottom. The other Directorates will be placed as per their merit. Points will initially be awarded out of 60 (1<sup>st</sup> Position - 60 points, 2<sup>nd</sup> Position - 57.5 points & 17<sup>th</sup> Position - 20 points, on the basis of 2.5 Points being reduced for each lower position.) and thereafter halved to convert the assessment out of 30 points allocated for this part of the competition.
6. The Directorates are required to forward the requisite information covering period from 01 December to 30 November to HQ DGNCC (Training 'B'/E') by 15 December each year, in the following format: -

<u>Ser No</u>	<u>NCC No</u>	<u>Rank</u>	<u>Name</u>	<u>Directorate</u>	<u>Group</u>	<u>Unit</u>	<u>Event</u>	<u>Duration</u>	
								<u>From</u>	<u>To</u>

## Annexure A7

### ACR - REGULAR AND WHOLE TIME NCC OFFICERS

1. **Aim.** The aim of this Competition is to ensure that Directorates submit the ACRs in respect of Regular and Whole Time NCC Officers by due date.
2. **Method of Assessment.** The results will be compiled as on 30th November.
3. Penalty Points will be awarded to Directorates when they fail to submit the ACRs by due date in the following manner: -
  - (a) Delay in Submission of ACRs. Penalty points will be awarded as follows:-

<b>No of Days</b>	<b>Penalty Points awarded per ACR</b>
1 – 30	1
31 – 60	3
61 – 90	9
91 - 120	10

(b) **ACRs Returned due to Technical Reasons.** In case of ACR returned for rectification of any technical flaw, one penalty point will be awarded for each reason. For example if an ACR is returned for the following reasons, the total penalty points awarded will be four: -

- (i) Correct Authority on Page 1 of CR is not mentioned.
- (ii) Wide variation between the consecutive reporting officers is not explained in the pen picture.
- (iii) Pen Picture is not written as one paragraph.
- (iv) Recommendations for promotion endorsed wrongly.

(c) Delay in Submission of Nominal Rolls of Officers & Completion Certificate. In case Directorate fails to forward nominal rolls of officers and Completion Certificates by due date the following penalty points will be awarded: -

<b>No of Days</b>	<b>Penalty Points</b>
1-7	1
8-14	2
15-21	3
22-28	4 and so on

4. The percentage of the penalty points awarded will be worked out as under: -

$$\frac{\text{Total penalty points awarded (Sub-Paras 3 (a), (b) \& (c) above) \times 100}{\text{Total Number of all types of ACRs}}$$

5. The points will be awarded out of 50. (Ist Position - 50 points, II nd Position - 47.5 points & XVIIth Position - 10 points. on the basis of 2.5 Points being reduced for each lower position.)

6. Details and Rules are given in Policy letters by MS Dte, HQ DG NCC from time to time.

7. The report covering the period from 01 Dec to 30 Nov next will be forwarded to reach DGNCC/MS(C) latest by 15 Dec.

8. DGNCC MS (C) will submit consolidated result to Training (Coord) Section of DGNCC by 20 Dec.

### **ENROLMENT OF CADETS**

1. **Aim.** The aim of this competition is to ensure full utilization of enrolment of cadets against allotted vacancies by NCC Directorates.

2. **Rules.** This competition has been allotted 10 Banner Points.

(a) The enrolment figures for total number of cadets in various Directorates will be worked out on the basis of their regimental fund contribution. Cadets' strength of NCC companies/troops placed on suspended animation will be deducted by P&C Directorate, DGNCC from the overall cadets' strength of the Directorates before sending these figures to P&F Directorate DGNCC for their calculation. The enrolment percentage will be worked out as under :-

$$\frac{\text{Cadet strength as obtained in Sub Para (a) above} \times 100}{\text{Allotted vacancies for enrolment}}$$

(b) The Directorate with the highest percentage will be placed on top and the others will be placed below in the order of merit of their percentages. Directorate achieving full enrolment will be awarded full points (ie 10 RD Banner points). Formula for awarding banner points is as follows:-

$$\frac{\text{Percentage of Enrolment} \times 10}{100}$$

(c) The contribution received from Directorates up to 30 Nov will only be taken into consideration. The report covering the period from 01 Dec to 30 Nov next year will be forwarded to DGNCC/PIg latest by 15 Dec.

3. Format of the report will be as under: -

<b><u>Category</u></b>	<b><u>Authorised</u></b>	<b><u>Enrolled</u></b>	<b><u>Enrolled</u></b>	<b><u>Score for</u></b>
			<b><u>Percentage</u></b>	<b><u>RD Banner</u></b>
			<b>A</b>	<b>(A x 10)/100</b>
<b>SD</b>				
<b>SW</b>				
<b>JD</b>				
<b>JW</b>				

### **TIMELY REPORTING OF OFFICERS, WTLOS, ANOS, PI STAFF & GCIs** **FOR CENTRALLY ORGANISED CAMPS AND COURSES**

1. Timely reporting of Officers/WTLOs/ANOs/PI Staff/GCIs and Cadets for RDC and courses at OTA Kamptee /Gwalior has been allotted 10 RD Banner points.

2. **Aim.** The aim of this competition is to ensure that 100 percent Personnel and Cadets detailed for centrally organised camps and other training courses at NCC OTAs report in time.

3. **Method of Assessment.**

(a) Assessment per Course/Capsule

$$\frac{\text{Total Number reported in time on first day of Course/Capsule X 10}}{\text{Total Numbers detailed from the Directorate.}}$$

(b) Overall assessment for all Course/Capsule from 01 Dec to 30 Nov.

$$\frac{\text{Sum of Points scored for attendance at each Course/Capsule}}{\text{Total Courses/Capsule detailed on}}$$

(c) Any late reporting due to late running of trains for any other unavoidable reason will not be taken into consideration unless supported by proper documentary evidence.

(d) Individuals who do not possess the requisite QR but report on due date will be treated as absentees. In both cases, two points per defaulter will be deducted as penalty.

(e) If the overall marks computed for the above purpose becomes negative, the same may be taken as zero.

4. **Compilation of Results.** NCC OTAs will keep a record of late reporting of Officers. WTLOs, ANOs, PI Staff, GCIs and Cadets on Courses/Capsules and compile details for the period from 01 December to 30 November. The compiled data will be forwarded to P&F Directorate (Pers) at HQ DGNCC under intimation to Training Directorate (Training 'B') and MS Directorate (MS 'A') by 15 December each year.

**Annexure A10**

**LOGISTIC CHECK OF DIRECTORATES BY BOARD OF OFFICERS**

1. **Aim.** The Aim of this competition is to streamline functioning of Logistic Cell at State level to make it more efficient.

2. **Method of Assessing.** A Logistic Data check will be carried out by the officers detailed from Logistic Directorate of HQ DGNCC. The officers will visit the Logistic institutions at State Directorate/ Group/Unit level and will check the following: -

**Marks Allotted**

(a)	Knowledge of PET/Policy Letter/Register and ledger maintenance	20
(b)	Inventory and Budgetary Control.	20
	Allotment	
	Expenditure	
	Balance	
	Proposed for next year	
	Bills balance for submission to CDA	20
(c)	Receipt of Stores.	
	Receipt of stores from consignee	
	Clearance of stores after Board of Officers held	

	Rejected stores and action taken	
(d)	Issue of Stores	20
	Issue to cadet as per scale	
	Surplus held with reason	
	Issue of stores down to NCC unit and procedure followed	
	Maintenance of ledger & clothing cards	
(e)	Stock Taking	10
	Procedure followed	
	Observations and reconciliation	
	Stock taking at the level of NCC Unit	
(f)	Accoutrement Items	10
	Authorization and quantity held	
	System of issue to cadets	
	Documents maintenance	

3. DDG Logistics will visit the State Directorates at least once in a year and will submit a report on the Logistics management of each State Directorate which will be included in compiling of marks for this competition.

## Annexure A11

### MANAGEMENT OF CLOTHING

1. **Aim.** The aim of this competition is to streamline procedures for management of clothing to include provisioning, issue, accounting and local purchase if required.

2. **Method of Assessment.** The assessment will be carried out as follows: -

(a) **Report & Return.** The clothing section will check Reports & Returns and assessment would be done based on following aspects: -

- (i) Timely submission.
- (ii) Correct reflection of figure as far as calculations are concerned.

(b) **LP Clothing.** It is seen that cadets are often provided with oversized/ undersized clothing and accoutrement items as per the scales laid down. Hence, it will be checked that the Directorates have spent the funds allotted based on projections made. In case funds are surrendered marks will be reduced, which will be awarded on the following criteria: -

- (i) Funds allotted
- (ii) Funds utilized
- (iii) Funds surrendered
- (iv) % of Fund Surrendered =  $\frac{\text{Funds Surrendered} \times 100}{\text{Funds Allotted}}$

(c) **Surplus Reported.** Provisioning in NCC is based on the cadets' enrolment planned in advance. In case clothing are rendered surplus unless there is a definite reason and a sanction has been obtained from Logistics Directorate, it will be presumed that cadets are not being kitted as per scales despite clothing held in stock. Hence percentage of surplus clothing against enrolled strength will be calculated. The Directorate having minimum surplus will get the highest marks. Based on the following formula: -

Surplus Clothing x 100  
Authorised Cadet Enrolment planned

3. Based on the above, the marks will be awarded to State Directorate. The Directorate standing first will be awarded 25 marks. The remainder Directorates as per their positions will have a difference of 1½ mark.

**Annexure A12**

**MANAGEMENT OF VEHICLES**

1. **Aim.** The aim of this competition is to streamline procedures for management of vehicles to include repair, down-gradation, back-loading of vehicles and the state of MT accidents.

2. **Method of Assessment.** The assessment will be carried out on following criteria: -

(a) **Budget Allotment for Repair.** Repair is required on vehicle once it is used but in case driving is efficient and vehicle maintenance is good utilisation of Budget for repair would be minimum. Hence any Directorate utilizing the minimum budget for repairs will score maximum marks. Calculation will be based as follows: -

$$\frac{\text{No of vehicles maintained} \times 100}{\text{Budget utilised}}$$

(b) **Down-gradation Vs Backloading of Vehicles.** It is seen that time lag between declaration of a vehicle as class V and its final disposal takes enormous time resulting in non-reflection of the same in vehicle casualty return. Thus, not being catered for provisioning at right time resulting in deficiency of vehicle in unit. Efficiency of back loading would be established as per formula given below: -

$$\frac{\text{Vehicle held for back - loading} \times 100}{\text{No of Vehicles declared Class V in a year}}$$

3. **MT Accidents:** Any MT accident which takes place anywhere will count against the Directorate. Details are given at Annexure A13.

4. Based on the above, the marks will awarded to State Directorate. The Directorate standing first will be awarded 25 marks. The remainder Directorates as per their standings will have a difference of 1½ mark.

6. While assessing the above aspects due credence will be accorded to functional commitments, ground conditions & geographical location of Directorate/Groups/Units as well as vintage of the vehicle and the justification given for seeking extra meterage.

**Annexure A13**

**MT ACCIDENT ASSESSMENT**

1. **Rules.** Any MT accident, which takes place anywhere, which involves a vehicle, an officer, PI Staff of the Directorate, Group or Unit will count against the Directorate.



2. It is further clarified that: -

(a) MT accident will count irrespective of seriousness of the accident or whether the court blames any individual/unit or not.

(b) The case will count only once and it will not be carried forward.

(c) The period for counting will be from 01 Dec to 30 Nov next year.

3. Accident Report must reach Directorate Gen NCC earliest but not later than 15 days of occurrence.

4. **Award of Points**

(a) Directorates with no accidents will be placed joint first and awarded full points.

(b) Directorate having accidents will be awarded penalty of 5 points per accident irrespective of number of vehicles held. No negative points will be awarded if the penalty points exceed 25 points.

**Annexure A14**

**MANAGEMENT OF EQUIPMENT**

1. **Aim.** The aim of this competition is to streamline procedures for management of equipment to include provisioning, issue, proper usage, disposal and accounting in the State Directorate.

2. **Method of Assessment.** The assessment will be carried out as follows: -

(a) **Equipment (Navy/Air).** The serviceable state of equipment is one of the most important indicators for imparting proper training to cadets in a Directorate. Hence percentage of serviceable equipment versus off-road state of equipment will be an important input for assessment for RDC banner. The basis of calculation would be: -

$$\frac{\text{Total Equipment of various Categories held on charge} \times 100}{\text{Off-road Equipment Held on Ground}}$$

(b) Repairs undertaken and budget asked. To be worked out on the same basis as being done for vehicles.

(c) **Ammunition Expenditure.** Expenditure of ammunition is an important indicator of the firing practices conducted in a Directorate. Hence, percentage of ammunition expended versus equipment held will indicate the firing carried out. Basis for assessment would be: -

- (i) Total No of Weapons (particular category) held
- (ii) Ammunition authorised for weapons as per scale
- (iii) Ammunition expended
- (iv) Balance ammunition left
- (v) Calculation

$$\frac{\text{Balance left} \times 100}{\text{Ammunition Authorised}}$$

3. Based on the above, the marks will be awarded to State Directorate. The Directorate standing first will be awarded 25 marks. The remainder Directorate as per their standings will have a difference of 1 ½ marks.

#### Annexure A15

### **MANAGEMENT OF LAND, ACCOMODATION & CIVIL WORKS**

1. **Aim.** The aim of this competition is to streamline management of land, accommodation and civil works at State Directorate level so as to improve the overall quality of life of NCC fraternity.

2. **Method of Assessment.** The Assessment will mainly on the basis of correspondence with Works Section, Reports and Returns and points relating to works and accommodation observed by DG and ADGs during their visits. Adm inspections to State Directorates will also be taken into account for awarding marks to the Directorates. The period assessed would be from 01 Apr to 31 Mar of preceding year.

3. The aspects, which will be assessed, are as follows: -

- (a) Timely submission of Reports and Returns.
- (b) State of Accommodation authorised and held.
- (c) Documentation and adherence to procedure in respect of new works, maintenance and Hiring.
- (d) Demand of funds, its utilisation and surrender, if any.

4. Based on the above, marks will be awarded to State Directorates. The Directorate standing first would be awarded 25 marks and difference of 1 ½ mark would be maintained between two Directorates.

#### Annexure A16

### **AUDIT OBJECTIONS / OBSERVATIONS**

1. **Aim.** The aim of this competition is to check the number of outstanding audit objections in NCC Directorates.

2. **Method of Assessment.** Only Central Govt audit objections would be taken into consideration. Special cases would be exempted by DGNCC on a case-to-case basis. Following method will be adopted for assessing the relative positions of the Directorates:-

- (a) The total number of audit objections pending as on 31 March will be taken into consideration from the Quarterly reports received from Directorates by 30 April.
- (b) The total number of audit objections will be divided by the number of Units to arrive at the average defaults per unit applying the following formula:

$$\frac{\text{Total No of Audit objections} \times 100}{\text{No of Units}}$$



(b) **Other Ranks (Other Than Officers).**

<u>Ser No</u>	<u>NCC No</u>	<u>Name of Cadets</u>	<u>Unit</u>	<u>Group</u>	<u>Name of Training Centre</u>	<u>Trade</u>	<u>Date of Joining</u>	<u>Enclosed selection letter No</u>

3. SD/SW cadets who joined Armed Forces during the period 01 Dec of previous year to 30 Nov will only be eligible for the competition. All entries must be filled in by the Directorate. Any misrepresentation or incomplete information will be considered as **one negative** entry.

**Example**

- No of Cadets who joined Armed Forces as Officers = 20
- Misrepresentation data forwarded in theses entries = 03
- Final Points accrued by directorate = 20-03-03 = 14

4. Every entry **must be accompanied by a proof of selection** without which entry will not be considered as eligible.

5. Cadets of **Sainik Schools will not be considered for the competition.** Every Dte must render a certificate to this effect.

6. The Dte wise score will be calculated as under with **special coefficient of 0.9 (Effectiveness Coefficient):-**

(a) **For Selection as Officer**

(i) Performance (P) of the Dte

$$P = \frac{\text{Total No. of Selections as Officer@}}{\text{Total No. of cadets (SD+SW) enrolled in the Dte}}$$

**@ - 1 pt per candidate , IF candidate has attended SSB Capsule or 0.6 pt per candidate, IF candidate has not attended SSB Capsule.**

(ii) Score of the Dte

$$S_{\text{officer}} = \frac{P}{P_{\text{Max}}} \times 25 \times 0.9$$

$P_{\text{Max}}$  is score obtained by the highest directorate

(b) **For Selection as Other Ranks**

(i) Performance (P) of the Dte

$$P = \frac{\text{Total No. of Selections as Other Ranks}}{\text{Total No. of cadets (SD+SW) enrolled in the Dte}}$$

(ii) Score of the Dte

$$S_{\text{Other Ranks}} = \frac{P}{P_{\text{Max}}} \times 10 \times 0.9$$

$P_{\text{Max}}$  is score obtained by the highest directorate

(c) Total Score of the Dte

$$S_{\text{Dte}} = S_{\text{Officers}} + S_{\text{Other Ranks}}$$

(d) The Total Score ( $S_{\text{Dte}}$ ) will be interpolated to 35 RD Banner Points as follows

$$\frac{\text{Score of Directorate } (S_{\text{Dte}}) \times 35}{\text{Score of Directorate with Max Score}}$$

**Appendix B**  
**(Refers to Para 3 of General Rules)**

**RULES FOR INTER DIRECTORATE NAVAL WING COMPETITIONS**

1. **General.** The Inter Directorate Naval Wing Competitions for **MENU, Sailing Competition, RDC** and annual **All India Nau Sainik Camp (AINSC)** will include the following events: -

<b>S No</b>	<b>Event</b>	<b>Venue</b>	<b>Total Points</b>	<b>RD Banner Points</b>	<b>Annexure</b>
(a)	MENU	As required	150	10	B1
(b)	Documentation Procedures	RDC	100	5	B2
<b>TOTAL</b>			<b>250</b>	<b>15</b>	
(c)	Ship Modelling	RDC	200	7	B3
<b>TOTAL</b>			<b>200</b>	<b>7</b>	
(d)	Service Exam (Written)	AINSC	200	10	B4
(e)	Seamanship (Practical)	AINSC	50	3	B5
(f)	Boat Pulling	AINSC	200	10	B6
(g)	Boat Rigging	AINSC	100	3	B7
(h)	Shooting / Firing	AINSC	100	7	B8
(j)	Drill	AINSC	100	7	B9
(k)	Semaphore/Communication	AINSC	100	3	B10
(l)	Ship Modelling	AINSC	200	7	B3
(m)	Best Cadets (SD & SW)	AINSC	150	8	B11
(n)	Line Area	AINSC	50	3	B12
(p)	Health & Hygiene	AINSC	50	2	B13
<b>TOTAL</b>			<b>1300</b>	<b>63</b>	
(q)	Sailing Regatta	INS Chilka	250	15	B14
<b>TOTAL</b>			<b>250</b>	<b>15</b>	
<b>Grand Total</b>			<b>2000</b>	<b>100</b>	

2. The Naval Wing competitions will carry 2000 marks. However, for RD Banner, these marks will be scaled down to 100 points. Rules governing various competitions are given in corresponding Annexure.

3. **Aim.** The aim of these competitions is to: -

(a) To give an exposure to salient aspects of Naval Wing Training and generate healthy competitive spirit by conducting Naval Wing Competitions contributing towards RD Banner.

(b) To foster a sense of discipline, leadership, comradeship and National Integration.

4. Based on present allocation, Dte wise vacancies for AINSC is given below. The terms and conditions for the nomination have been given at para 14 below.

<b>S. No</b>	<b>NCC Dte</b>	<b>No of Cadets</b>	
		<b>SD (Boys)</b>	<b>SW (Girls)</b>
1.	Andhra Pradesh	28	12
2.	Bihar & Jharkhand	18	12
3.	Delhi	18	12

S. No	NCC Dte	No of Cadets	
		SD (Boys)	SW (Girls)
4.	Gujarat	23	12
5.	Jammu & Kashmir	18	12
6.	Karnataka & Goa	28	12
7.	Kerala & Lakshadweep	28	12
8.	MP & Chhattisgarh	23	12
9.	Maharashtra	28	12
10.	NER	18	12
11.	Odisha	23	12
12.	P H HP & C	28	12
13.	Rajasthan	18	12
14.	TNP & AN	28	12
15.	Uttar Pradesh	23	12
16.	UK	18	12
17.	WB & S	18	12
	<b>Total</b>	<b>386</b>	<b>204</b>

### Selection of Cadets for Nau Sainik Camp

5. The norms for nomination of cadets have been based on the presumption that each Directorate would field the best team for the RDC and the AINSC for RD Banner events. The team members are selected from amongst the best cadets in the naval units. Since each directorate has different number of Naval Units, directorates with more number of naval units get advantage over others with lesser number of naval units as they have bigger choice in selecting the cadets for the AINSC thereby have better chances of performing better than others.

6. To overcome the disparity, participation of all the units in a directorate in forming the directorate team for RDC and AINSC is mandatory.

7. The directorate team will be formed by fielding the average number of cadets from each naval unit of the directorate. The total number of cadets in the directorate team will be divided by the number of naval units in the directorate. The lower full number will be the minimum number of cadets from each Directorate. Directorates will have the privilege of fielding the balance cadets from any of the naval unit. However, in such cases, only one cadet per naval unit can be fielded.

### Example:

If a directorate with 5 NUs will have team = 28 SD and 12 SW  
Average number of cadets per unit  
(SD) =  $28/5=5.6$  R/O 5 (Lower full number)  
(SW) =  $12/5=2.4$  R/O 2 (Lower full number)  
Dte will field 5 SD & 2 SW per Naval Unit =  $5 \times 5=25$  SD &  $5 \times 2=10$  SW  
Balance Cadets =  $28-25 = 3$  SD &  $12-10 = 2$  SW  
i.e total **5 Cdt**  
Dte will field these 5 Cadet@ 1 Cdt/Unit = 5 (3SD + 2 SW).

**Note:** If the number of balance cadets is less than no of units in a Directorate. In this case, Directorate can pick up the cadets from any of its naval units @ 1 cadet/naval unit of its choice.

8. Contingents are to nominate cadets for various events in advance and a consolidated list of the teams including reserve cadets is to be handed over to the camp Commandant on arrival. The composition of the teams for competition will be as follows:

<b>S No</b>	<b>Event</b>	<b>Event Strength All Nominated</b>	
		<b>SD</b>	<b>SW</b>
(a)	Service Exam (Written)	70%	70%
(b)	Seamanship (Practical)	30%	30%
(c)	Boat Pulling	8 (including 2 reserve)	8 (including 2 reserve)
(d)	Boat Rigging	8	NIL
(e)	Shooting / Firing	3 (including 1 reserve)	3 (including 1 reserve)
(f)	Drill (AINSC)	13 SD/SW {09 SD + 03 SW cadets (03 ranks x 04 files) with 01 Parade Cdr (SD /SW)}	
(g)	Semaphore/Communication	50%	50%
(h)	Ship Modelling*	3 (1 Main + 2 Helpers) (At least one SW is mandatory in the team)	
(i)	Best Cadet SD & SW	34	17
(j)	Line Area	All available SD cadets	
(k)	Health & Hygiene	02	02

9. **Selection of Cadets for RD Competition during AINSC.** The rules for selection and participation of cadet in RD Competition are as follows: -

- (a) Directorates to nominate cadets for each competition. No draw of lots will be held for any event.
- (b) At the time of joining the camp the Directorates will submit the list of cadets participating in the various events.
- (c) Each Cadet will have to participate in at least one RD Banner Competition.

10. **Marking System.** Directorate scoring highest aggregate in all the competitions will be awarded first position in Inter Directorate Naval Wing Competitions. Points towards RD-Banner will be subsequently awarded out of 100 points on the percentage system up to second decimal place i.e. based on actual marks scored in the RD Banner competition score.

11. **Trophies/Shields/Medals.** Trophies/Shields/Medals etc will be awarded as follows: -

- (a) **During Nau Sainik Camp.** Following trophies will be awarded for the respective competition.

<b>S.No</b>	<b>Category</b>
(i)	Best Directorate in Service Exam (Written)
(ii)	Best Directorate in Seamanship (Practical)
(iii)	Best Directorate in Pulling
(iv)	Best Directorate in Boat Rigging
(v)	Best Directorate in Power Boat Handling
(vi)	Best Directorate in Firing
(vii)	Best Directorate in Parade Training
(viii)	Best Directorate in Semaphore
(ix)	Best Directorate in Line Area
(x)	Best Directorate in Ship Modelling



(xi)	Best Directorate in Health & Hygiene
(xii)	Captain of the Camp SD
(xiii)	Captain of the Camp SW
(xiv)	Over all Best Directorate

(b) **During RDC.** Following trophies are to be awarded for the respective competition.

<b>Ser</b>	<b>Category</b>	<b>Remarks</b>
(i)	PM's Rolling Trophy	MENU
(ii)	CNS Trophy	Best Directorate in Naval Wing Training
(iii)	Ship Modelling Trophy	Best Directorate in Ship Modelling

(c) In addition, cadets securing 1st, 2nd and 3rd position in following competitions will be awarded Gold, Silver and Bronze medals respectively.

<b>Ser</b>	<b>Competition</b>	<b>Gold</b>	<b>Silver</b>	<b>Bronze</b>
<b>Non-RD Banner Competitions</b>				
(i)	Best Cadet (Boy/Girl)/Captain of the Camp	1+1	1+1	1+1
<b>RD Banner Competitions</b>				
(ii)	Boat Pulling (Boy/Girl)	8+8	8+8	8+8
(iii)	Firing (Boy/Girl)	1+1	1+1	1+1
(iv)	Ship Modelling (Boy/Girl)	3+3	3+3	3+3
(v)	Health & Hygiene (Boy/Girl)	2+2	2+2	2+2
(vi)	Drill	13	13	13
(vii)	Semaphore/Communication(Boy/Girl)	1+1	1+1	1+1
(viii)	Service Exam (Written) (Boy/Girl)	1+1	1+1	1+1
(ix)	Seamanship (Practical) (Boy/Girl)	1+1	1+1	1+1

(d) For Ship Modelling in following categories during RDC:-

<b>S.No</b>	<b>Competition</b>	<b>Gold</b>	<b>Silver</b>	<b>Bronze</b>
(i)	Camp Model	3	3	3
(ii)	Sailing Model	3	3	3
(iii)	Equipment Model	3	3	3

12. **Judges and Compilation of Results.** While the Directorates conducting the competitions at AINSC will make all administrative and safety arrangements, actual competition, judging, compilation and declaration of results will be carried out by a Board of Naval Officers other than those posted to any NCC Directorate/Gp/Unit, whenever possible. Conducting Directorate will carry out necessary liaison with the LNA (Local Naval Authority) for nomination of the required judges. Dir/JD Trg (Navy) shall act as the DG NCC representative for the camp. All Naval officers posted at HQ DGNCC shall be nominated as the OICs of Watermanship, Non- watermanship and Ship Modelling competitions in addition.

13. **Protest/Objections/Complaints.** All protests/objections/complaints are to be verbally lodged before the Protest Committee within 15 minutes of the completion of the event followed by a written complaint to the Protest Committee within an one hour of the competition. These will be referred to the Jury of Appeal and all protests, objections; complaints will be dealt with, as per rules. The jury of appeal would include following: -

- |     |   |          |
|-----|---|----------|
| (a) | Flag Officer/Commanding Officer (Commodore & above) of the Naval Establishment/visiting ADG/DDG (HQ DGNCC). | Chairman |
| (b) | HQ DG NCC Representative (Captain IN)   | Member   |
| (c) | OIC Watermanship Competitions from HQ DG NCC  | Member   |
| (d) | OIC Non-Watermanship Competitions from HQ DG NCC  | Member   |
| (e) | OIC Ship Modelling Competition from HQ DG NCC   | Member   |

14. **Eligibility for Participation in RDC and AINSC**

- (a) A cadet who has once represented a Directorate in a Competition will not take part in the same competition again except that if he/she has taken part as a JD/JW cadet, he/she may take part once more as SD/SW cadet.
- (b) A cadet is permitted to participate in AINSC and RDC only once. Cadets may attend RDC post AINSC but not vice versa.

15. **Selection and Training.** All Cadets taking part in watermanship activities are to be swimming qualified.

16. **Change in Rules/Venue.** Notwithstanding the above, DG NCC may modify the above rules or venue of the competitions at any moment of time.

17. **Safety and Security.** Safety of the cadets is paramount at all the times. Directorates are to adhere with safety instructions issued from time to time. Dte conducting a waterborne activity will issue detailed safety instructions prior conducting the event.

**Annexure B1**

**MOST ENTERPRISING NAVAL UNIT COMPETITION (MENU)**

1. The criteria for selection of the most enterprising NCC naval unit for the award of the PM's Trophy shall be on the basis of Sailing Expeditions undertaken by the unit and the Whaler-Pulling statistics for the period from 01 Nov of previous year to 31 Oct of the current year.

2. Units will be evaluated out of a total of 150 marks/15 RD Banner points as follows: -

- |                         |           |
|-------------------------|-----------|
| (a) Sailing Expeditions | 125 marks |
| (b) Whaler-Pulling      | 25 marks  |

3. **Sailing Expedition (125 Marks) Award of Marks** Following aspects on award of marks shall be considered;

- (a) **Distance.** Marks against distance covered to a maximum of 20 marks will be as follows:

<b><u>S.No</u></b>	<b><u>Distance Covered</u></b>	<b><u>Marks</u></b>
(i)	Upto 50Kms	00

(ii)	51 Kms to 100 Kms	05
(iii)	101 Kms to 150 Kms	10
(iv)	151 Kms to 200 Kms	15
(v)	201 Kms and above	20
<b>Note:</b> Distance covered is to be measured from point to point.		

- (b) **Duration.** 01 mark per day to a maximum of 10 marks shall be awarded.
- (c) **Number of Boats.** 10 marks per NCC operational whaler (Excluding support boats) completing the expedition to a maximum of 30 marks shall be awarded.
- (d) **Number of Cadets.** 0.5 mark per cadet to a maximum of 30 marks shall be awarded. In addition, 01 Bonus marks for every 05 SW cadets to a maximum of 05 marks will also be awarded.
- (e) **Publicity.** A maximum of 20 marks, based on the efforts towards publicity by the unit shall be awarded.
- (f) **Adventure and Enterprising Spirit,** 10 marks shall be awarded towards the spirit of adventure and enterprise exhibited by the crew during the expedition. Spreading social awareness through Nukkad, Street Shows, Rallies etc during the expedition will attract up to 10 bonus points. Presentation of report will also have due weightage.

5. **Whaler Pulling (25 Marks)** 01 mark for every 20 hrs of whaler pulling in a training year to a maximum of 25 marks by a NU within the stated period shall be awarded. (Total Max 25 Marks)

6. All NCC Directorates will submit MENU Detailed report by **30 Nov** as per format below. Reports received after the due date will entail a penalty of 10 marks. Reports received after 20 Dec, shall not be considered Directorate are to ensure that reports are delivered to HQ DGNCC well in time. Incomplete report shall be treated as no reports and will attract penalty as applicable. Report must have adequate photographs and videos with date and location details.

### **PM'S ROLLING TROPHY - MOST ENTERPRISING NCC NAVAL UNIT**

- Name of the Naval Unit ..... Det.....
- Detailed report from 01 Nov..... To 31 Oct.....

<b>S No</b>	<b>Events/Item</b>	<b>Details</b>	<b>Remarks if any</b>
(a)	Distance (KM)	Kms	
(b)	Duration (in Days)	Days	
(c)	No of Boats		Only operational boats completing expeditions be mentioned
(d)	No of Crew	SD	No of cadets manning each boat be indicated
		SW	
(e)	<b>Publicity</b>		Details of publicity efforts made and News Paper/ Magazines/Clippings CDs/VCDs/ Photographs etc are to be attached
	News Paper		
	TV		
	Radio/ Photo/Video		
	Social Awareness		
	Nukkad		
	Stage Shows		

	Rallies		
(g)	Adventure		Independent report to be submitted
	Whaler-Pulling (Hrs)	Hrs	

Date: \_\_\_\_\_

Commanding Officer  
Naval Unit NCC**COUNTERSIGNED & DATE (ADG/DDG)**

7. **Award of RD Banner Points.** The marks scored by an NU of a Directorate shall be reduced to RD Banner points on percentage system upto two decimal points. In the event of a Directorate conducting more than one expedition, the Directorate has the option of fielding any NU of his choice for the competition.

8. **Safety and Security.** Safety of the cadets is paramount at all the times. Directorates are to adhere with the guidelines issued on the subject from time to time. Safety instructions, are to be issued and read out to the cadets by the team leader prior conducting any water borne activities by the Naval Units of NCC.

9. **Personnel for Expeditions.**

(a) **Officers.** A regular Naval Officer is to be in overall charge of the expedition.

(b) **Sailors.** One PI Staff (Senior Sailor) of the Seaman Branch, proficient in sailing, is to remain present in each boat through the expedition. This sailor would also act as in-charge of the boat.

(c) **Cadets.** Cadets detailed for the expedition are to be: -

- (i) Volunteered for the expedition
- (ii) Physically & Medically fit.
- (iii) Swimming test qualified.
- (iv) Be proficient in boat pulling and sailing.

10. **Boats and Gear.** All boats participating in the expedition are to be checked for the sea worthiness and must be cleared for the expedition by the team leader. Boats proceeding to sea are to be checked for the sea worthiness.

11. **Boat Equipment.** Boat equipment considered mandatory during the expedition as per instructions in Manual of Seamanship (BR 67) 1995 are to be ensured on board. In addition, following equipment are mandatory for the sailing/pulling expedition: -

(a) **Life Jackets.** Operational Life Jackets at the scale of one per member of the expedition plus a minimum of 25% reserve.

(b) **Life Buoys.** A minimum of 2 Life buoys per boat are to be carried on-board.

(c) **Signalling Equipment (In each Boat)**

- (i) Semaphore Flags - One Set
- (ii) Aldis Lamp with 2 sets of batteries - One
- (iii) Varey's Pistol - One
- (iv) Cartridges for Varey's Pistol - 4 Red, White & Green

- (v) Torch with spare set of Batteries - One
- (vi) Oil Lantern and Matches - As Required
- (iv) Navigation Lights. - As Required
- (v) First Aid Kit. - As Required

(d) **Drinking Water.** Sufficient drinking water is to be carried in each boat for the entire crew for each leg/phase of the expedition plus a minimum of one day's reserve.

## 12. **Personnel/Equipment for Support Party**

(a) **Personnel.** A suitably equipped support party is to be constituted and kept ready to render assistance to the expedition at short notice. This support party will normally consist of the following personnel (additional personnel may be included to cater for local conditions):-

<b>SNo</b>	<b>Personnel</b>	<b>No</b>
(a)	Officer (Regular/Whole Time)	One
(b)	PI Staff (Seaman Branch) (PO Rank or above)	One
(c)	Jr Sailors/Boat Keepers/Lascars familiar with Boat Pulling	Two
(d)	Medical Attendant	One
(e)	Good Swimmer	One

(b) **Equipment.** The support party may be embarked in road transport/boat depending on the nature of the expedition, this party should be equipped with the following gear :-

- (i) Operational Dinghy/Gemini Craft with OBM and sufficient fuel.
- (ii) Signalling equipment with sufficient spare batteries.
- (iii) Two ropes of size 2" to 2 ½" and of length 120 fathoms each.
- (iv) First Aid Kit.

**Note:** - The above list includes only minimum requirements. Other items of equipment as considered necessary may be included, according to the nature of the expedition.

(c) **Safety/Ship/Boat.** Whenever a open sea expedition is planned, a safety ship/boat is to be detailed to accompany the expedition. The safety ship/boat is to maintain frequent contact with the expedition boats.

## 13. **Planning and Execution**

(a) **Recce.** A detailed recce of the entire course of the expedition is to be carried out by a regular Naval Officer. When the expedition is planned in the rivers, particular care must be taken to identify narrow gorges, rapids, rocks, bars and shallow patches, where boats are likely to be endangered. The recce party must mark the channel to be used by the expedition.

(b) **Weather.** The period chosen for the expedition should be free from cyclonic storms and seasonal bad weather, which hampers the conduct of such expeditions. The local forecast and state of weather should also be taken into account before the commencement of the expedition.

14. **Planning and Conduct.**

(a) Based on the recce, a thorough and detailed plan must be made of each phase of the expedition outlining the route to be followed, the distance to be covered in each day, confining the activities to daylight hours. Planning must also include the administrative back up for the expedition, safety orders and alternate courses of action in the event of accidents, bad weather, failure of safety boats, damage to boats and failure of communication.

(b) The expedition boats are to remain in contact with the safety boat throughout the expedition. The contact may be visual or through radio.

(c) Dte are to intimate HQDGNCC/DDG Trg the brief expedition plan atleast one week prior to commencement.

15. **Manning of Boats.** Cadets and PI Staff detailed for manning of boats during the expedition should not exceed the following: -

(a) Whalers –Min 7 Max 10 depending on the nature of expedition

(b) Dinghies - 3 subject to prevailing weather conditions

(c) Other Boats - As stipulated by the makers of the boat

16. **Handling of Boats.** During the expeditions, the boats are to be handled in accordance with instructions in Manual of Seamanship (BR 67) 1995 edition. All precautions and safety instructions laid down and issued from time to time are to be strictly followed.

17. **Wearing of Life Jacket.** Half inflated Life jackets are to be worn by all the personnel (Officers, I Staff and Cadets) prior to entering the boat and are to be removed only on returning ashore.

18. **Swimming.** Swimming is strictly prohibited when boats are underway. However, when boats are at anchor, permission may be granted by the OiC Expedition after careful assessment of the local conditions and posting a qualified lifesaver as lifeguard with a life buoy. A strict watch is to be kept on all personnel in the water and a muster is to be carried out of all personnel before and after swimming.

19. **Safety Orders.** Detailed safety orders are to be issued and read out to the cadets by the Officer in charge of the expedition covering all aspects of the expedition.

20. All cadets participating in sailing expeditions, which involve a risk to life, are to be group insured by the respective Directorate to cover accidents resulting in death or injury to those participating in the expeditions.

**DOCUMENTATION PROCEDURES**  
**LETTER OF PROCEEDINGS ON NAVAL TRAINING (LPNT)**

1. **Aim.** To develop the practice of data recording on naval training and evolution of training equipment to words m maximum utilisation by the naval wing cadets.
2. **General.** All directorates will be assessed on their quarterly achievements towards naval training for 100 Marks out of which 05 RD Banner points will be awarded to the directorates on the basis of their performance in the year. Since RD Banner is awarded during PM's Rally in Jan every year, the assessment will commence each quarter starting 01 Jan every year. Following aspects will be included while evaluating a directorate at HQDGNCC: -
  - (a) Cadets Status
  - (b) Equipment Status
  - (c) Equipment Utilisation
  - (d) Naval Training
  - (e) Camps
  - (f) Social Activities
  - (g) Documentation
3. Directorate are forward report on LPNT for quarter ending 31th March, 30 June, 30 September & 31 Dec by 10<sup>th</sup> day of April, July, October & Dec respectively. The report is required to be received at HQ DGNCC (Hard Copy or E-Mailed) by due date failing which 10 overall marks will be deducted. Thereafter 01 Mark on each day delay will be deducted. Reports received after 28<sup>th</sup> day of the month will not be counted and the Directorate will attract Zero points. The format of the LPNT is at Annexure B-1.
4. **Conduct.** Marks to the dte will be awarded based on the dte achievement during the year commencing 01 Jan (RDC Being in Jan every year). The training syllabus, procedures, reports, returns, goals will be the basis for the assessment. Notwithstanding the above, Director General NCC may modify the QRs or part of it depending upon the availability of equipment, resources, administrative compulsions and conditions existing during the period of report.
5. **Distribution of Marks.** The procedure on distribution of marks (maximum) and the minimum standard against each activity will be as per format below. Directorate will be awarded based on the achievement during the period. However, the conduct of the directorate, strength, participation of SW cadets, duration, degree of difficulty, application of innovative ideas, presentation, publicity etc will get due weightage. Marks will be deducted for not conducting a event in a year.

**MARKS ALLOCATION QUARTER ENDING - ..... 20 .....**

S No	Activity	Marks
(a)	Submission of Returns in time	10
(b)	Naval Activities	15
(c)	Social Activity	10
(d)	Environmental Awareness	10

(e)	Contribution towards Organisation	10
(f)	Writing skill	10
(g)	Innovation towards Eqpt Maintenance	15
(h)	Aid to Civil Admin	10
(j)	Any other as projected	10
<b>Total</b>		<b>100</b>

**Annexure B3****RULES FOR INTER DIRECTORATE SHIP MODELLING  
COMPETITION AT AINSC& RDC**

1. **Aim.** The aim of the competition is to:
  - (a) To enhance awareness about naval forces and ship design and impart practical experience on precision Modelling.
  - (b) To assess the level of proficiency achieved by various directorates.
2. **Teams.** The ship modelling team for RDC and AINSC would consist of three nominated naval cadets (one Main and two Helpers). Each Dte must have at least one SW cadet in any capacity in the team (Main / Helper).
3. **Models for Competitions.** The ship modelling competition will encompass following categories of ship/boat models: -
  - (a) Each Directorate will field Sailing and Display Model each. NCC Directorate to send only those models, which have been prepared by the Directorate ship modelling team during the current training year. A certificate as per format\* from the Directorate is to accompany the model. Directorate to ensure that a cadet is permitted to prepare only one model. No cadet in any capacity (main or helper) cannot prepare more than one model under any category.

**CERTIFICATE**

This is to certify that the Ship Model \_\_\_\_\_ (Name of the Model) \_\_\_\_\_ for the Ship Modelling competition has solemnly been prepared by this \_\_\_\_\_ (Directorate Name) \_\_\_\_\_ Ship Modelling Team and not by professionals/ ship modelling Instructors/Mechanics.

The Ship Modelling Team\* (Total 3 Cadets with at least one SW cadet is mandatory) for the above model is as follows: -

S No	Regimental No	Unit	Cadet Name	College
1				
2				
3				

**ADG/DDG**

- (b) One powered model will be prepared by the Ship Modelling Team at the camp known as Camp Model. The ship modelling teams will bring the kits and tools



required for the construction of the model from the Directorate. A summary of the models, teams, team composition and event is as under: -

S No	Model	Team	Team Composition	Remarks
(a)	Display Model (RDC)	1 Main + 2 Helpers All Nominated	It is mandatory to have at-least one SW cdt in each team. Cadet can participate only once in any of the team. Cadet participated in AINSC can participate in RDC	Pre-assembled RDC
(b)	Sailing Model (RDC)	1 Main + 2 Helpers All Nominated		Pre-assembled RDC
(c)	Camp Model. (RDC & AINSC)	1 Main + 2 Helpers All Nominated		To be prepared at Camp RDC and AINSC

(c) **Size.** The Size of the Model produced by the Dte under any category shall be the same as given in the blue print supplied with the kit by the vender. It is mandatory to submit the signed and stamped blue print of the model by the Dte. Marks shall be awarded based on the dimension given in the blue print.

4. **Competition.** This is broadly divided into two major events, Static and operational. The latter is further sub divided into stability and performance. Details of these events are given in Paragraphs 5 to 7.

5. **Judges.** The DGNCC will arrange for suitable judges from IHQ, MOD (N) for the competitions at RDC. Judges for AINSC will be arranged locally by the Camp Commandant.

6. **Static Event.** During RDC, all the three (Two Directorate models + one Camp model) will be displayed on a table and assessed by the judges nominated by the DG NCC for their details of construction, fittings and overall elegance. During NSC, model prepared by Dte will be assessed by the judges arranged by camp comdt.

7. **Operational Event.**

(a) **Stability.** All models will be judged for their stability in water with a reasonable free board.

(b) **Performance.** The performance of the models will be judged as follows: -

(c) **Camp Model**

(i) The Camp Model will be made to traverse under own power to a distance of about 10 to 15 meters in water in a straight line. Marks will be awarded according to the margin of errors in the course of the model, the least error obtaining the highest position.

(ii) Turning circle of the ship with rudder fixed to port or starboard. Ship with shortest turning radius will score maximum marks.

(d) **Sailing Model**

(i) The model will have to traverse from one side of the pool to the other side. Model finishing first will be the winner.

- (ii) Where a model touches the side of the pool or returns back to start line, or fails to take off, the contestants will have the liberty to reset the sail from the same position without giving any physical impetus to the boat.

8. **Modification.** Models brought or built at camp should be as faithful to specifications supplied by the manufacturers as possible. Small qualitative changes to improve performance, especially in rudder and propeller, is permissible, **Application of grease/oil to submerged outer surface of the model is not permitted.** Grease/oil may be applied to motor etc. as recommended by the manufacturer or if considered necessary for improving the performance of the motor etc. Marine fittings as appropriate may be added to enhance the performance/appearance of the model.

9. **Tools and Accessories.** The teams will bring their own tools & accessories required for construction of the Camp Model. Adequate number of battery cells to cater for trial runs and the actual competition, with some margin for displays, should be brought by the teams. The Camp authorities will supply none of the above.

10. **Change in Rules.** Notwithstanding the above, Directorate General NCC may modify the above rules according to the availability of resources and conditions existing at the time of the completion.

11. **Guidelines for Allotment of Marks.** The tables below give various categories of models, number of entries, marks allotted, number of chances permitted in performance trials of these competitions and guidelines. The types of models nominated in each category will be officially intimated to the Directorates.

12. **Marks Allocation Table**

<b><u>S. No</u></b>	<b><u>Model</u></b>	<b><u>Nos of entries</u></b>	<b><u>Static RDC\ AINSC</u></b>	<b><u>Stability RDC\ AINSC</u></b>	<b><u>Operational Performance</u></b>	<b><u>Total</u></b>	<b><u>No. of Chances for Performance</u></b>	<b><u>Type of Model</u></b>
(a)	Display Model	1	100/NA	-	-	100	-	As nominated by DGNCC
(b)	Sailing	1	15/NA	10	25	50	1	
(c)	Camp Model	1	100/130	10/15	40/55	150/200	2	

**Notes:**

- (i) Judges will be given a brief on marking system well in advance.  
(ii) Judges may make an alteration in the number of attempts permissible at their discretion.

13. **Procedure.** The detailed procedure for the conduct of ship modelling competition during AINSC, in order to eliminate guesstimate, is contained in succeeding paragraphs. The teams will need to carry the signed with date & stamp blue prints of the models.

14. **Marks Allocation** Marks allocation for each category shall be as follows: -

<b><u>S No</u></b>	<b><u>Model</u></b>	<b><u>Marks at RDC</u></b>	<b><u>Marks at AINSC</u></b>
(a)	Display Model	100	-
(b)	Sailing Model	50	-
(c)	Camp Model	150	200
<b>Total</b>		<b>300</b>	<b>200</b>

15. **Breakdown of Marks Allocation**(a) **Display Model (100 Mks)**

<b>S No</b>	<b>Description</b>	<b>Marks at RDC</b>
(i)	Scale/Dimension	05
(ii)	Basic Fittings	15
(iii)	Weaponry	15
(iv)	Radars/Antennas	15
(v)	Helicopter	05
(vi)	Display Case	10
(vi)	Paint Work	15
(vii)	Overall Seaman Look	20
<b>Total</b>		<b>100</b>

(b) **Sailing Model (50 Mks)**

<b>S No</b>	<b>Description</b>	<b>Marks at RDC</b>
<b>(a)</b>	<b>Static</b>	
(i)	Construction	5
(ii)	Fittings/Sails	3
(iii)	Elegance	7
<b>Total</b>		<b>15</b>
<b>(b)</b>	<b>Stability</b>	
(i)	Return to Original position	5
(ii)	List and Trim	5
<b>Total</b>		<b>10</b>
<b>(c)</b>	<b>Operational Performance</b>	
(i)	Sailing across the Tank	10
(ii)	Sail Design	5
(iii)	Seaman Eye	10
<b>Total</b>		<b>25</b>
<b>Grand Total</b>		<b>(a+b+c) = 50</b>

(c) **Camp Model (150/200 Mks)**

<b>S No</b>	<b>Description</b>	<b>Marks RDC</b>	<b>Marks AINSC</b>	
<b>(i)</b>	<b>Static</b>			
	(aa)	Construction/Design	15	20
	(ab)	Basic Fittings	20	25
	(ac)	Weaponry/Radars/Antennas	25	30
	(ad)	Helicopter	05	10
	(ae)	Paint Work	10	15
	(af)	Elegance	25	30
<b>Total</b>		<b>100</b>	<b>130</b>	
<b>(ii)</b>	<b>Stability</b>			
	(aa)	<b>Steady Condition</b> (aa) Rests on even keel (No trim or List)	05	10
	(ab)	<b>After Tapping</b> (ab) Returns to original list / trim	05	05

	(ac) Capsizes	0	0	
<b>Total</b>		<b>10</b>	<b>15</b>	
<b>(iii) Operational Performance:</b>	Two trial runs for Straight and Turning Circle assessment may be given to the cadet before final test.			
	<b>Straight Run:</b> - The model is to run under own power along the length from the center of the tank/pool straight to the			
(aa)	Model to sail along the length of the tank, straight to 12" width Center Band of on opposite breadth. Model reaches the next adjacent Band of equal size on either side of the center will get 01 point less and so on to a minimum 10 and 15 points in RDC and AINSC respectively	25	35	
<b>(iv) Turning Circle</b>	<b>Turning Circle.</b> Model take 360° turn with fixed Rudder angle under own power.			
	(ab)	Model with smallest turning circle will earn full marks. Other models will get one mark less for every 5 cm increase in the turning circle.	15	20
	<b>Total</b>		<b>40</b>	<b>55</b>
<b>Grand Total</b>		<b>150</b>	<b>200</b>	

16. **Procedure for Conduct of Operational Performance.** Procedure for conducting the operational performance test shall be as follows: -

(a) **Camp Model.**

(i) **Straight Run.** The mid points on the longer sides at about 10 to 15 mtrs of the rectangular tank will be marked by paint/chalk. One of these two mid-points will be designated as start point. A band extending about 6" on either side (A band of 12") of the finishing point will be marked at water level as Central Band for 25 & 35 marks each for RDC and AINSC respectively. Adjacent to this band, 10 more bands of 12" each on both its sides will be marked on the water level. Model will be made to sail under own power from the start point towards the marked bands. Model hitting the central band will get full marks. Points shall be deducted depending upon the deflection from the central band.

(ii) **Turning Circle.** The powered ship model with pre-determined rudder angle is to be put in tank from one of the sides of the tank with its heading parallel to other side, pointing as per Cadet's discretion but well clear of the tank's side. Once the ship model has turned through 90°, two of the Judges standing on opposite sides of the water tank will place the aluminium bar tangential to the outer side of the model and parallel to the shorter side of the water tank and leave on deck. This process will be repeated with the second bar, when the model has turned through 270°, the Judges will place the second aluminium bar tangential to the outer side of the model and parallel to the shorter side of the water tank and leave it also on deck. The distance between the inner sides of the two aluminium bar will be measured on both the sides and the average of the two readings will be recorded. Each model will be permitted two attempts. The shorter of the two readings will be counted towards score.

(b) **Sailing Model.** Four Sail Models in sequence as decided by the Judge are to be judged each group. The sailing Model with pre-determined rudder and sail position is put in water. The direction is to be decided by the judge taking into the consideration of the prevailing wind pattern. The model reaches first across the tank will get first position. The model with best timings will be the first and will get full marks.

#### Annexure B4

### RULES FOR INTER DIRECTORATE WRITTEN EXAM ON SERVICE SUBJECTS COMPETITION AT AINSC

#### Aim

1. To judge the knowledge of cadets in Service Subjects to assess the level of proficiency achieved by various directorates in training.

#### Venue

2. Competition will be held at Nau Sainik Camp.

#### Composition of Directorate Team

3. 70% of SD & SW cadets of each Directorate would participate in the competition. Balance of 30% cadets would participate in practical examination of Seamanship. The Ship Modellers are exempted from participating in this competition.

#### Dress

4. Uniform.

#### Allocation of Marks

5. A total of 200 marks points will be allocated to this competition.

#### Examination

6. The written examination on service subjects would be conducted as part of AINSC for which the question paper would be made by HQ DGNCC. Camp Comdt would nominate the Board of Officers to evaluate the answer sheets.

7. Paper would be made from Cadet's Hand Book. Examination would be conducted in service subjects comprising of 2nd year syllabus of Non-Technical group on Specialised subjects.

8. Duration of Examination would be two hour.

9. The marks scored by each cadet of Directorate would be averaged out to get the final result of competition.

10. **Judges for the Competition.** The judges for the competition will be nominated by DGNCC.

**RULES FOR INTER DIRECTORATE SEAMANSHIP  
EXAM (PRACTICAL) ON COMPETITION AT AINSC**

1. **Aim.** To judge the practical knowledge of cadets in Seamanship to assess the level of proficiency achieved by various directorates in training.
2. **Venue.** Competition will be held at Nau Sainik Camp.
3. **Composition of Directorate Team.** 30% cadets (who have not been nominated for Service Subject Written competition) of each Dte excluding Ship Modellers will participate in the competition.
4. **Dress.** Uniform.
5. **Allocation of Marks.** A total of 50 points will be allocated for this competition.
6. **Examination.** The practical examination on Seamanship (Bends & Hitches) would be conducted as part of AINSC as follows: -
  - (a) The concerned Naval Command HQs/DGNCC would provide a Board of Officers to evaluate the practical exam.
  - (b) The practical examination would be conducted for following bends & Hitches.
  - (c) Each cadet would draw four chits from the box and perform the practical within 05 minutes at the examination area. The cadet would also be asked oral question on the bends & hitches.

SNo	Bend & Hitches	SNo	Bend & Hitches	SNo	Bend & Hitches
(i)	Reef Knot	(v)	Rolling Hitch	(ix)	Timber Hitch
(ii)	Figure of Eight Knot	(vi)	Round Turn and Two Half Hitch	(x)	Bowline
(iii)	Clove Hitch	(vii)	Bowline on the Bight	(xi)	Double Sheet Bend
(iv)	Marling Hitch & Single Sheet Bend	(viii)	Timber Hitch and Half Hitch	(xii)	Marline Spike Hitch

- (d) The marks scored by each cdt of would be averaged out to get the final result of competition.

Ser	Event	Marks Allotted
(i)	Correctness	20
(ii)	Neatness	10
(iii)	Timely Completion	10
(iv)	Knowledge / Purpose	05
(v)	Oral Questionnaire	05
	<b>Total</b>	<b>50</b>

7. The marks scored by each cadet of Directorate would be averaged out to get the final result of competition.

### Judges for the Competition

8. The judges for the competition will be nominated by DGNCC.

## Annexure B6

### RULES FOR INTER DIRECTORATE BOAT PULLING REGATTA AT AINSC

#### General

1. This competition will be conducted at the AINSC. The aim of the competition is to:-

- (a) To assess the level of proficiency achieved by various directorates.
- (b) To inculcate spirit of adventure and team spirit among the cadets.

2. The responsibilities guidelines, general rules and conduct of the races are as follows: -

(a) Depending upon the previous performance, Directorate teams are to be grouped into four groups, based on international rules, as follows: -

<b>A</b>	<b>B</b>	<b>C</b>	<b>D</b>
1	2	3	4
6	5	7	8
10	9	11	12
16	15	13	14
- - - 17			

(b) **Step 1.** All seventeen teams be grouped into four groups (A, B, C and D) based on the performance of previous AINSC as above.

(c) **Step 2**

- (i) Each group has one race.
- (ii) To ensure complete fairness, there would be a separate draw for lane as well as boat before each race.
- (iii) Total No of races would be 8 (4 SD + 4 SW).

(d) **Step 3**

- (i) The participants of the races are grouped into group E and F as under: -
  - (aa) **Group E.** 1<sup>st</sup> of group A&C and 2<sup>nd</sup> of group B&D.
  - (ab) **Group F.** 1<sup>st</sup> of group B&D and 2<sup>nd</sup> of group A&C.
- (ii) These two groups would compete for positions 1 – 8.
- (iii) Total No of races would be 4 (2 SD + 2 SW).

(e) **Step 4**

- (i) The other participants would be grouped into groups G & H on similar lines and would compete for positions 9 - 17. The boat coming fifth in whichever group would be placed in group H.

- (ii) These two groups would compete for positions 9 - 17.
  - (iii) Total No of races would be 4 (2 SD + 2 SW).
- (f) **Step 5.** Groups E, F, G and H have one race each (a total of 8 races 4 SD + 4 SW) and get grouped as under: -

- (i) **Group J.** First two of groups E and F. These four teams would compete for positions 1-4.
- (ii) **Group K.** Third and fourth of group E and F. They will compete for positions 5 – 8.
- (iii) **Group L.** First and second of group G and H. They will compete for positions 9 – 12.
- (iv) **Group M.** The rest of the five teams. They will compete for 13 – 17 positions.

- (g) **Step 6.** Groups M, L, K and J have one race each in that order and all positions decided as per the standing in each of these groups (A total of 8 races 4 SD + 4 SW).

**Note:** Total No of races  $8 + 8 + 8 = 24$

3. Draw of the Directorates, boats and lanes will be conducted at the site in the presence of the team in charges or their representatives, on the day of the competition.

### **Judges**

4. DGNCC is to nominate three judges, of the rank of Lt Cdr and above from Naval Command in consultation with the conducting Directorate. As far as possible no officer posted to any NCC Directorate is to be nominated as a judge.

### **Conduct of the Race**

5. Boats will take positions in their respective lanes. The starter must ensure that boats are in line and none has any headway or sternway. Starting orders will be as under: -

- (a) 'Oars Forward'
- (b) 'Stand by'
- (c) 'Go' accompanied by a hand flag signal brought down with simultaneous firing of a gunshot/hooter/whistle.

**Note:** In case of wrong start, the starter will waive a large red flag or fire a red cartridge/from Valey's light pistol/blow hooter continuously. In that case, all boats are to be brought back to the starting line for a fresh start. A gun will be fired when the first boat crosses the finishing line. Flag signal from the marker boat mat also be used.

6. In case of the inclement weather or any unforeseen conditions, the lanes, procedure, distances etc may be changed by the board of the officers consisting of DG Rep, Camp Commandant, OIC Watermanship from HQ DGNCC. The amended procedure is to be explained in detail to the respective Contingent Commander/Reps one day prior to the event.

### **Marks to be Awarded**



7. The SD or the SW team of the Directorate securing 1<sup>st</sup> Position will be awarded 100 points and subsequent teams will be awarded points on a sliding scale with a difference of 2.5 points. Total of points scored (out of 200) by both SD and SW team of Directorate would determine the position of team in the regatta.

<b>S.No</b>	<b>Position</b>	<b>Marks</b>
(a)	1 <sup>st</sup>	100 points
(b)	2 <sup>nd</sup>	97.50 points (100 - 2.50)
(c)	3 <sup>rd</sup>	95.00 points (97.50 - 2.50)
(d)	4 <sup>th</sup>	92.50 points (95.00 - 2.50) and so on with a difference of 2.5 between each position and the 17th position will get 60 points.

#### 8. **General Rules**

(a) At start the boats are to maintain their respective lanes. Subsequently a boat, which is ahead of others, may take any lane. Overtaking boat is to change lane only when at least two boat lengths ahead, otherwise the Chief Judge may disqualify the overtaking boat.

(b) It is the duty of an overtaking boat to keep clear of other boat /boats being overtaken. Any boat found wilfully fouling another boat would be disqualified.

(c) Coxswains are not to resort to pulling. They may however assist a crewmember in re-shipping/replacing his oar.

(d) In case of rudder being damaged/unshipped coxswains may use the spare oar for steering the boat but not for sculling.

(v) Use of drugs and stimulants by the crew is strictly prohibited and will entail disqualification.

(f) Slogan raising of any kind/showing any flag other than Directorate flags/signalling by any means during the conduct of competition is strictly prohibited. However, cheering for a team during the race by the cadets ashore is acceptable.

(g) Protest/Objections, if any, is to be lodged with any of the Jury member present at the venue in writing within 30 min of completion/closing of the event.

(h) Results of the event will be announced after disposing off protest/objections, if any.

(j) During the conduct of Regatta, due regard shall be paid to the safety of personnel and equipment, participating/employed in this event and the instructions issued by the Directorate Gen NCC time to time in this connection are to be strictly complied with.

(k) The race shall be conducted in 27-foot GRP Whalers.

#### **Re-run**

9. A boat which has been fouled, is not entitled to a re run of the race but if the chief judge, paying due regard to her chances of winning, considers it desirable, the race may be re-run.

#### **Course**

10. The race will be run approximately over a distance of five cables for SD (one cable-200 yards) in a straight line as far as practicable and four cables for SW (800 yards).

### **Rig for the Crew**

11. The following rig will be worn by the crew: -

<b><u>S No</u></b>	<b><u>Dress</u></b>		<b><u>Remarks</u></b>
	<b><u>SD</u></b>	<b><u>SW</u></b>	
(a)	White Shorts	White Salwar/Track Lower/ Shorts, White T shirt	1. Cadets may use mutton cloth/handkerchief to protect hands during pulling.
(b)	White Vest	Directorate 'T' Shirt	
(c)	PT/Sports Shoes		
(d)	Blue Socks		
(e)	Gloves Mutton Cloth (Optional)		
(f)	Half inflatable life jacket around the neck		
(g)	Jersey/Track suit top		

**Note:** Tracks Suits may be worn except for the final race deciding 1 to 4 positions.

### **Turn Out**

12. Crews should be meticulously turned out since public will continuously watch them during the event.

13. **Prizes** The Inter Directorate Boat Pulling Cock will be presented to the winning Directorate on the final day of the NauSainik Camp. In case of tie the trophy would be shared by each Directorate for 6 months. The directorate to carry the trophy first will be decided by toss.

### **Guidelines on Safety and Security**

14. **Introduction.** The safety rules to be observed during the practices and the finals of Regatta are given in the succeeding paragraphs. These safety rules are the guidelines for the safety precautions to be observed by officers, PI staff and cadets participating in this Regatta. These rules are compiled from Seamanship Manual (BR 67) 1995 edition and various relevant sources.

15. Whilst every effort has been made to make these safety rules as comprehensive as possible to cover all contingencies, it is not possible to cover all contingencies in such situations. Therefore, personnel are advised to revert to advice/instructions tendered in Seamanship Manual (BR 67) and other relevant publications and the dictates of common sense as circumstances of the situation may warrant. Where, for some reasons, there has been a departure in these rules from those laid down in Seamanship Manual Vol I and II, the Seamanship Manual will supersede these instructions.

16. **Conditions of Boats and Fittings.** It is to be ensured that the boats designated as main and stand by for the regatta (boats and dinghies) are generally in overall good condition and there are no serious hull defects that may affect the seaworthiness of the boat during its employment during the Regatta. Special attention should be paid to the following aspects: -

- (a) The hull should be waterproof to ensure that there is no possibility of ingress of water, which can, in any way, endanger its safety.

- (b) All damaged items especially planks, keel box and buoyancy tanks etc are repaired properly and have been inspected.
- (c) All the necessary fittings required for pulling and sailing, such as mast, sails, thwarts stretchers etc, are in state.
- (d) The bilge rails of boat and dinghies and the lifelines of boat are ok.
- (e) All the securing gear such as ringbolts, towing bollards, wires, ropes have been checked.
- (f) The rudder and its fittings are well secured and the tiller is provided with its split pin to ensure that it does not slip out whilst in use.
- (g) The plugs of the boats are properly fitted and the boat is watertight.

17. **Checking the Equipment.** Before taking out the whalers/dinghies for use during the practices/heats/regatta, coxswains is to ensure that the boat is correctly rigged. Coxswain is to doubly ensure the following: -

- (a) **Plug.** Is to be secured in its hold properly with no leakage.
- (b) **Oars.** Full complement of oars with one spare oar is to be ensured. It is particularly important that a dinghy equipped with only one pair of sculls should carry a spare oar.
- (c) **Crutches (Single-Banked Boats).** Full complement of oars with one spare to be ensured. Crutches are to be secured by its lanyard to the boat.
- (d) **Stretcher.** Is to be fitted in place for each thwart.
- (e) **Rudder.** Is to be shipped with lanyard secured to after ringbolt.
- (f) **Tiller.** Is to be shipped and secured with its split pin.
- (g) **Painter.** This is to be shackled to the stem ringbolt.
- (h) **Towing Bollard.** If portable, it is to be in the boat with its clamp & pin.
- (j) **Wearing of Life Jackets.** The crew is to wear half inflated Life jackets at all the time during sailing/pulling.

18. **Conduct of the Crew in the Boat.** When entering a boat, the crew should step on thwarts they should avoid stepping on the gunwale and move carefully in the boat. Movement of personnel in the boat must be kept to the absolute essential when underway. Even when the boat is alongside, movements inside the boat must be controlled and orderly. The crew member or passenger in the boat should not lean or rest any part of his body on the gunwale nor should any part of his body extend outside the hull of the boat except when specifically required to balance the boat during sailing.

19. **Loading of Boats.** The boat should not be loaded with personnel or material beyond the stipulated capacity. The maximum of personnel that may be embarked in boats is given below: -

- (a) Whaler - 10 Cadets
- (b) Dinghy - 03 Cadets

20. In addition to reducing loading to the number of personnel specified above, due heed must be paid to the positioning of personnel/material in the boat to ensure that the boat remains on an even keel. Extra care while loading a boat is to be exercised so that boat does not become top heavy and therefore unstable.

21. **Weighing of Boats.** All the Boats participating in the race are to be weighed independently. Boats are to be of equal weight by adding sand bags in the lighter boat.

22. **Precautions During Sailing.**

- (a) Sheets should be kept in hand and not belayed.
- (b) All the boat crew to wear half inflated life jackets at all the times while sailing/pulling.
- (c) When sailing, no one should stand on the thwarts or climb the mast.
- (d) If the gear is fouled aloft and cannot be cleared with a boat hook, crew must stand on the bottom boards while clearing the foul.
- (e) Alternatively, the sails is to be lowered to clear it.

23. **Handling in Rough Weather.** Attention of the coxswains is drawn to the condition that may occur during sailing in rough weather. The precautions and remedial action that should be taken as laid down under these headings in Seamanship Manual (BR 67) page 5-77 to 5-92. All the coxswains and crew are to be fully conversant with these actions and must be able to put them into practice if the situation warrants it.

24. **Drop Keel.** In a small boat, when keel is lowered, it lowers the center of gravity of the boat and make the boat more stabilized. When the keel is lowered, the resistance offered by the water to its surface reduces any tendency of the boat to roll but when the boat is under sail and making leeway, this lateral resistance will produce a capsizing movement. The movement is not appreciable under normal conditions of beating and reaching but may become dangerous if the boat is blown broadside to leeward by a sudden squall or if she yaws badly or broaches to when running. The drop keel should always be raised if there is chance of the boat running aground because if it hits the bottom not only might it become bent which might prevent it from being raised, it may also capsize the boat or even split her open.

25. **Safety Boat.** A minimum of one power boat should always remain available as safety boat during the conduct of the regatta. The safety boat should carry the following: -

- (a) One swimmer qualified in life saving.
- (b) Two life buoys.
- (c) Six spare life jackets.

26. **Safety Officer.** A safety and rescue officer is to be detailed by name by conducting Directorate. This officer will be responsible for ensuring safety during practices and during the Regatta.

27. **Conclusion.** The above rules are only general guidelines for the safety of these expeditions, they are by no means comprehensive and are to be read in conjunction with Manual of Seamanship (BR 67) 1995 edition and other relevant publications. Where there has been a departure in these rules from those laid down in the Manual of Seamanship 1995 edition, the Seamanship manual will supersede these instructions.

**INTER DIRECTORATE BOAT RIGGING COMPETITION****Aim**

1. The aim of the competition is
  - (a) To judge the practical knowledge of the cadets on basic seamanship.
  - (b) To assess the level of proficiency achieved in planning, leadership qualities and team work
  
2. Inter Directorate Boat Rigging Competition will be conducted during AINSC as part of the Line Area Inspection Competition. Modalities for the conduct of the competition are as under: -
  - (a) **Event.** One 27' DK Whaler is to be rigged to proceed to sea by each directorate. The boat and the rigging gears as per list will be provided by the conducting Directorate.
  - (b) **Venue.** As decided by the Camp Commandant.
  - (c) **Dress.** The rig will be the PT Rig i.e Track lower/short, T-shirt with Chest No, sports shoe, Seamanship knife. Use of unauthorized tools/nails, etc will attract negative mark as decided by the judge. Life jackets are exempted for the event.
  - (d) **Participation.** Each Dte to nominate eight cadets including two reserve cadets to form a team. Team Leader may select any eight cadets before start of the event.
  - (e) **Judges.** The Judges for the competition will be as follow:
 

(i)	Commander (Executive Branch)	(01)	-	LNA
(ii)	Bosun Officer (Cdr/LCdr)	(01)	-	LNA
(iii)	MCPO/CPO (Seaman Branch)	(01)	-	LNA
  - (f) **Procedure.** The procedure for the competition will be as follows:
    - (i) Boat and the gears for the competition will be provided at the venue by conducting Directorate.
    - (ii) Teams/team of six will muster at the start line and the team captain will make report to the Chief Judge "**KastyDulTaiyyar Hai Sreeman**". Teams are to be inspected by the judges and marked for the correctness of rigs and their seaman appearances.
    - (iii) Teams will be given 05 min to muster the gears kept near the boat as per the list provided by the Judges by blowing of whistle. Discrepancy, if any, is to be brought to the notice of the judges. No complaint shall be entertained thereafter.
    - (iv) Teams will re-muster at the start line and on the long whistle by the Judge, teams/team will proceed to their respective boats/boat and commence rigging. The Judge will start the Stop Watch and note the time in the score sheet provided for the competition. Teams are to complete the rigging within 10 Min maximum. A long whistle will again be sounded after 10 Min. At the whistle, teams are to leave the boat at its and will muster at the Start Line.

(v) As and when a team completes boat rigging, the team will fall back at the start line and the team captain will report to the Judge "**Kasty Taiyyar Hai Sreeman**". The Judge will stop the Stop Watch and record the time taken to complete the event in the score sheet in the appropriate column.

(vi) Judges will inspect each boat independently and will award marks on the score sheet provided for the purpose. Teams are to remain closed up at the Start Line during the inspection by the judges.

(vii) On completion, the team at the start line will be ordered to unrig the boat accordingly on the order of "**Kasty Khali Karo**" by Judge, Time keeper will start the Stop Watch. The teams are to unrig their respective boat and secure the gears and place them at the designated place. Team on completion will muster at the Start Line and the team leader will make report to the Judge "**Kasty Khali Hai Sreemaan**". Boat and gears will again be inspected and assessed for correctness by the judges independently. The score sheet fully completed and signed by the respective Judge is to be handed over to the OIC Watermanship Competition in a sealed envelope before commencing next assessment.

(viii) These envelopes are to be opened by the Board of the Officers who will also compile the results. The following officers will constitute the BOO:

- (aa) OIC Watermanship/HQ DGNCC
- (bb) Nominated by HQ DGNCC
- (cc) Nominated by HQ DGNCC

### **Conduct**

3. Teams and the boat for the competition are to be drawn by draw of lots. Score sheet will be explained by the Chief Judge.

4. DK Whalers are to be beached/put on chinks at least 15 mtr apart from each other. Start line will be drawn by the conducting Directorate.

### **Assessments and Marks**

5. A total of 100 marks (reduced to 10) shall be counted towards the competition. The breakdown of the marks as follows:

(a)	Rig of the crew	-	05
(b)	Rigging of Boat	-	70
(c)	Un-rigging of Boat	-	20
(d)	Discipline	-	05

### **Annexure B8**

#### **RULES FOR INTER DIRECTORATE SHOOTING COMPETITION AT AINSC**

1. **Aim.** The aim of the competition is to assess the firing standards of directorates and provide motivation to develop firing as skill for competition at National and International level.

2. **General.** Shooting competition will be a team event. Separate competition will be held for each of the following categories with points noted against each: -

- (a) Senior Division - 160 points max (40 X 2 x 2)

(b) Senior Wing - 160 points max (40 X 2 x 2)

3. Inter Directorate Shooting Competition will carry 100 points. Inter Directorate position will be worked out only after totalling marks of all the participants. The marks will be awarded based on the percentage of maximum marks obtained by a directorate and reduced to same percentage of 100. e.g. if a directorate gets 240 marks out of 320, marks obtained by the directorate towards RDC/AINSC would be  $240/320 \times 100 = 75$

4. **Venue.** Shooting competition will be held at AINSC. Venue will be selected by Camp Commandant in consultation with OIC Competitions, where the requisite firing ranges are available.

5. **Dress.** Uniform with ankle boots.

6. **Conduct.** Responsibility for conducting these competitions will be that of a Board of Officers detailed by OIC Competitions and composed entirely of officers nominated by DGNCC. Presiding Officer will declare score of each category on the spot and submit the scores to OIC Competitions within 24 hrs. Overall Inter-Directorate position for whole of shooting competition will be compiled by OIC Competitions subsequently after all matches are completed.

7. Camp Commandant will only make the administrative and safety arrangements for the competition. Firing Point and Butt will be manned by an Officer of the Board of Officers nominated by DGNCC. Assistance of Camp PI Staff will always be made available to the Board of Officers.

### **Strength and Competition of Teams Practice and Scoring**

8. **Composition of Teams.** Each Directorate team will consist of three SD and SW cadets each. In addition, one cadet will be as reserve. These cadets will be from within the total vacancies allotted for the Camp and selected at random as per policy.

9. **Tie Breaker.** In case of a tie between firers for individual prizes (I, II and III of each category), the following procedure will be adopted: -

(a) **For Application.** In the event of tie, all affected firers will be made to fire grouping practice applicable to their Wing. Size of the group will be taken into consideration to decide the individual position. In case the tie still persists, it will be broken as indicated at Sub Para 9 (b) below.

(b) **For Grouping.** All affected will fire the same practice again. In case tie still persists, the grouping will be fired again within one minute and later reduced by 10 seconds each time till the positions are decided.

10. **Administration.** Camp Comdt will be responsible for all admin arrangements incl the following:

(a) Range allotment and clearance. He will ascertain from OIC Competitions in advance, the dates on which range is required.

(b) Coordinating with OIC Competitions the date and programme of the competitions.

(c) Safety precautions including provision of sentries.

- (d) Provision and proper distribution of ammunition.
- (e) Arranging armourer with tools at the Firing Point.
- (f) Provision of targets, flags, jackets and target patching material.
- (g) Practising the Competitors in Range Drill.
- (h) Provision of Firing Point and Butt Registers.
- (j) Buglers.
- (k) Establishment of Kote and ammunition store in the Camp.
- (l) First aid box and medical Staff. He will also position an Ambulance Vehicle at the Firing Point for the duration of the Competition.
- (m) Tele communication.
- (n) Transportation of cadets and stores to range and back.
- (p) Stop watch.

11. **Weapons.** .22 Service pattern Rifle of any mark (Mk III or IV), Deluxe / Sporting rifles would only be allowed. Directorates are permitted to use their own service weapons and ammunition including foreign/imported ammunition for the competition (not exceeding 4 in number). The Rifles will be properly zeroed before being brought to the Camp. During the journey the rifles will be carried by the PI Staff and not by the cadets. Directorates bringing own arms and ammunition are to follow laid down service rules and procedure for transportation to and fro. The Directorates unable to do so may liaise in advance with Conducting Directorate of the Camp for provisioning of weapons and ammunition.

12. **Ammunition.** The Camp Commandant will provide ammunition including for zeroing and warmer rounds out of the ammunition brought by the Directorates.

13. **Practices.** Two practices of Grouping and Application will be fired as follows:-

- (a) **Grouping**  
 Distance - 25 Mtrs/yards (Depending upon the firing range).  
 Number of rounds - Five.  
 Position - Lying with rest.  
 Target – 1x1 Grouping Target.  
 Highest Points - 40  
 Time - Own Time.

**Scoring**

- 2.0 cms and below 40 Points
- 2.5 cms -do- 36 Points
- 3.0 cms -do- 32 Points
- 3.5 cms -do- 28 Points
- 4.0 cms -do- 24 Points
- 4.5 cms -do- 20 Points
- 5.0 cms -do- 16 Points
- 5.5 cms -do- 12 Points



6.0 cms -do- 08 Points  
 6.5 cms -do- 04 Points  
 Above 6.5 cms -do- 00 Points

(b) **Application**

Distance - 25 Metres/yards.  
 No. of rounds. - Five.  
 Position - Lying without rest.  
 Target - 1 x 1 Application Target.  
 Highest points - 40  
 Time. - Own Time.

**Scoring**

Bull - 8 Points  
 Inner - 6 Points  
 Magpie - 4 Points  
 Outer - 2 Points

14. **Warmer Rounds.** Two warmer rounds will be allowed at the beginning of the competition each day when the rifle is fired for the first time.

15. **Misfire/Stoppages.** In case of a misfire or stoppage, additional exposure/ammunition will be permitted. But in case a competitor fails to fire within the laid down timings, no extra time exposure will be provided.

16. **Zeroing.** Directorate teams desirous of checking zeroing of weapons of their cadets can do so before commencement of the competition if facilities are so available.

**Award of Points to Directorates**

17. Points scored by the cadets in each practice will be totalled and average taken to arrive at the score of the Directorate in that competition. Award of medals will, however, be based on individual performance of cadets. Cadets securing, I, II and III position in each competition will be awarded individual prizes before dispersal from the Camp where competition is held. Inter Directorate Shooting Trophy will be awarded at the AINSC Camp where competition is conducted.

**RULES FOR INTER DIRECTORATE DRILL COMPETITION AT AINSC**

1. **Aim.** The aim of the competition is to instil sense of discipline and pride among cadets and to assess ability of cadets to perform correct and coordinated drill movements.
2. **Composition of Directorate Contingent.** Each Directorate Contingent will consist of thirteen cadets (09 SD and 03 SW cadets and one Contingent Commander). Participants will be drawn from within the authorized Naval Strength of the respective Directorate.
3. **Sequence of Action.** The contingent will be formed in three rank and four files just behind the line marked for inspection by the judges. The screening will commence with senior cadet stepping out to take permission from the Chief Judge. The sequence of events and drill movements are as follows: -
4. **Dress.** The competition will be conducted in two parts as under.
  - (a) All participating cadets are to be dressed in Dress No 8A - Summer Wear, as follows: -
    - (i) Beret NCC Cap Badge/ White/Pagri Badge & Red Hackle.
    - (ii) Shirt White.
    - (iii) Name plates, Bilingual with white base and black lettering.
    - (iv) Trousers White.
    - (v) Socks White.
    - (vi) Boots Black Leather.
    - (vii) Belt Nylon white with NCC Buckle.
    - (viii) Sling Rifle Web White
    - (ix) Accoutrements, such as badges of rank, proficiency badges, certificate examination badges, authorised camp badges and adventure activity badges as per Dress regulations.
  - (b) Points will be deducted if cadets are found not wearing appropriate or wearing unauthorised badges/stripes of rank, NCC certificate proficiency badges, shoulder titles and such like accoutrements as per NCC Dress Regulations. For each mistake in uniform of a cadet ½ penalty point will be added to Contingent's score.
  - (c) Wearing of white gloves during Drill Competition is not permitted.

**Conduct**

5. The competition will be conducted in two parts as under:-
  - (a) **Part-I** Inspection of contingent and foot drill without Arms.
  - (b) **Part-II** Drill with Arms and March Past.

**Conduct of Part I**

(To commence on indication of hand signal from Judge to senior cadet).

6. The contingent commander comes to SAVDHAN turns about and gives the following Command:-

- (a) Khuli Line Chal
- (b) DahineSaj

7. After “**DAHINESAJ**” the senior cadet will turn about and report to the Judge “**(Name) DIRECTORATE CONTINGENT APKENIRIKSHANKELIYETAIYYAR HAI SHRIMAAN**” salutes, turns about, marches off to his designated position for inspection. Once the Judge has inspected the contingent, the senior cadet will commence the drill in the sequential order given below after giving orders for nikat line chal :-

- (a) Dahine Mur
- (b) Baen Mur
- (c) Peeche Mur
- (d) Dahine Mur
- (e) TejChal
- (f) Dahine Salute (At Flag Marker)
- (g) SamaneDekh (At Flag Marker)
- (h) Peeche mur
- (j) Baen Salute (At Flag Marker)
- (k) Samne Dekh (At Flag Marker)
- (l) Tham
- (m) Line Thor

8. After doing these movements the senior cadet will take permission to perform the second part. “**BHAG DO SHURUKARANE KI AAGYACHAHATA HUN, SHRIMAAN**”

9. Once the permission is given, before commencing Part-II of the Drill competition, for seeking permission to pick up the Rifles the following word of command will issued. “**SHASTRA UTHANNEKELIYEDAURKECHAL**”

### **Conduct of Part II**

10. Arms drill will be carried out with 7.62 mm SLR Rifles. The contingent will pick up the Rifles (on the double) and fall in again at the place earmarked in “**BAJU SHASTRA**” position. Once the directorate contingent is properly formed the senior cadet will ask “**BHAG DO SHURUKARNEKEAAGAYA DE, SHRIMAAN**” and perform the drill in the following sequence: -

- (a) Bagal Shastra
- (b) Baju Shastra

- (c) Salami Shastra (the Sr cadet will salute along with the contingent)
- (d) BajuShantra
- (e) Bagal Shastra
- (f) Baen Mur
- (g) Peeche Mur
- (h) TejChal
- (j) Dahine Salute (At Flag Marker)
- (k) SamneDekh (At Flag Marker)
- (l) Peeche Mur
- (m) Baen Salute (At Flag Marker)
- (n) SamneDekh (At Flag Marker)
- (p) Tham
- (q) Dahren Mur
- (r) Seek permission to march away (Go back and deposit Rifles)

### **Marking**

11. The total marks for Part I and Part II will be 100. The scores for each part will be marked separately as follows: -

(a) **Part I (Marks 40)**

<b>S.No</b>	<b>Event</b>	<b>Marks</b>
(I)	Coming up on Parade and forming up 2 ½	05
(II)	Turn out and smartness 2 ½	05
(III)	Foot Drill and Turning Movements 10	10
(IV)	Steadiness on Parade & Dressing of File and Rank 0	05
(V)	Marching and Saluting 10	10
(VI)	Word of Command 05	05
<b>Total</b>		<b>40</b>

(b) **Part II (Marks 60)**

<b>S.No</b>	<b>Event</b>	<b>Marks</b>
(I)	Rifle Drill movements	15
(II)	Marching & Dressing of files and rank	15
(III)	Saluting and distances between files	15
(IV)	Word of Command	15
<b>Total</b>		<b>60</b>

**RULES FOR INTER DIRECTORATE SEMAPHORE  
COMPETITION AT AINSC****Aim**

1. The aim of the competition is to develop skills of visual communication and assess the level of proficiency achieved by various directorates.

**Venue**

2. Competition will be held at Nau Sainik Camp.

**Composition of Directorate Team**

3. 50% of SD & SW cadets of each Directorate would participate on random selection. The two SD & SW Ship Modellers are exempted from participating in this competition and hence not a part of draw.

**Dress**

4. Uniform.

**Allocation of Marks**

5. A total of **100** points will be allocated for this competition.

**Examination**

6. Format for examination would be as follows: -

(a) Transmitting speed will be 10 words per minute.

(b) The exam will be conducted in two parts. Firstly, the message transmitted will contain in the initial part 10 groups of numbers followed by a paragraph of approximately 50 words.

(c) The transmission will be read by one cadet and noted by other both in case of SD and SW. Then the pairs are to be exchanged and the test repeated with different paragraph and alpha-numeric words.

(d) Cadets would be provided NC 1 form. Correct formatting would be awarded 10 points and wrong format would be awarded zero points in the overall computation of marks.

7. The marks scored by each cadet of Directorate would be averaged out to get the final result of the competition.

**Judges for the Competition**

8. The judges for the competition will be nominated by DGNCC.

**RULES FOR CONDUCT OF BEST CADET COMPETITION DURING  
AINSC (NON-RD BANNER COMPETITION)**

1. **Aim.** The aim of the Best Cadet Competition is: -
  - (a) To encourage cadets of the Naval Wing of all Directorates to excel in multiple disciplines and develop leadership qualities.
  - (b) To provide outstanding cadets an opportunity to compete in a healthy environment and get a sense of achievement.
  
2. **Team Composition.** Each Directorate will nominate 02 SD and 01 SW cadet for the competition.
  
3. **Eligibility.** The cadet nominated for the Best Cadet Competition: -
  - (a) Must have attended a minimum of one camp.
  - (b) Must have attended minimum of 75% of parades conducted during each year of his/her NCC training.
  - (c) Must have participated at least in one of the sailing activities. (Sailing Expedition/ Sailing Regatta/ MENU)
  - (d) Must have been nominated in the following Competition in current AINSC
    - (i) Service Subject (Written)
    - (ii) Drill
    - (iii) Firing/shooting
  
4. **Nominal Roll.** Each Contingent Commander is to submit a Nominal Roll of his Best Cadet Team to the Camp Commandant upon arrival at the Camp.
  
5. **Conduct.** The best cadet from SD and SW will be selected as the Best Cadet of the Camp every year. The competition will be of 50 Marks each for SD and SW. The marks distribution will be as follows: -

<b><u>S No</u></b>	<b><u>Activity</u></b>	<b><u>Marks</u></b>	<b><u>Remarks</u></b>
(a)	Service Subject Written	200	Marks obtained in the respective competitions at the Camp.
(b)	Drill	100	
(c)	Firing/shooting	100	
(d)	Interview by BOO	75	Officers of HQ DGNCC
(e)	Final Interview	25	By visiting VIP from HQ DG NCC/ Conducting Directorate ADG/DDG
<b>Total</b>		<b>500</b>	These marks will be reduced to 75 each for SD & SW both to get the final marks.

6. **Standard Procedure.**
  - (a) Directorate will hand over the list of cadets appearing for the Best Cadet Competition (02 SD & 01 SW each) of the respective Directorate to the OiC Non Watermanship Competitions.

(b) OiC Non Watermanship Competitions to prepare a consolidated list of Candidates by Directorate.

(c) Marks obtained by the cadet in the competitions at 5(a-c) above are to be endorsed on the Score sheet as per format below by the OiC Non Watermanship Competitions and handed over to the DG Rep {JD Trg (Navy)} in sealed envelope named as Score Sheet – 1(Master Score Sheet).

Name	Directorate	Chest No	Service Subject (1)	Drill (2)	Firing (3)	Interview view.*	Average (4)	Final Interview (5)**	Total Score 1+2+3+4+5	Position
						A				
						B				
						C				
						A				
						B				
						C				
						A				
						B				
						C				
						A				
						B				
						C				

\* A, B & C are the board Members

\*\* Final Interview by VIP Visiting the camp/ADG/DDG of conducting Dte.

(d) A Board of Officers consisting of officers from HQDGNCC will constitute the Board. The DG Rep {JD Trg (Navy)} even if the Presiding officer will also act as the secretary of the board.

- (e) The Board will evaluate the cadets on the following aspects:
- (i) Personal Bearing, turnout, disposition and mannerism.
  - (ii) Communication skill, clarity of thought and expression.
  - (iii) Comprehension and intelligence.
  - (iv) Response/Ability to react.

(f) Marks awarded to a cadet by individual board member (incl President of the Board) are to be handed over in a sealed envelope to the secretary of the Board (DG Rep {JD Trg (Navy)}) (Sheet-2) individually.

(g) Marks obtained in the Final interview by the visiting VIP from HQ DG NCC/Conducting Directorate ADG/DDG are to be obtained in sealed envelope by the DG Rep-{JD Trg (Navy)} (Sheet-3)

(h) The same BOO will assemble again and the envelope (Sheet 1-3) will be opened and the marks will be compiled by the DG Rep. {JD Trg (Navy)} on the Master Score Sheet. Cadet (SD and SW) scoring maximum will be declared First.

**RULES FOR LINE AREA COMPETITION AT AINSC****Aim**

1. The aim of the competition is to show case the artistic, conceptual and imaginative skills of the cadets working as a team and set standards of excellence.

**General**

2. The Line Area Competition will cover the line area of SD Cadets only. Venue of the competition will be Nau Sainik Camp. All available cadets including un-utilised reserves for various events may participate. The competition will be held in tents/ built up area. This will carry 50 marks. The points would be subdivided as under:-

- (a) Line Area - 35 points
- (b) Tent Pitching - 15 points

3. No unauthorized and / or fancy items will be displayed in the Line Area.

4. Each contingent will bring two fire extinguishers, one fire hook, one fire beater and four buckets for the Competition. Extravagant display of fire fighting equipment like CGI Sheet / Tin Roofing of the fire point is not required. The equipment should be in serviceable condition.

5. A board of officers will be detailed by OIC competitions to assess the Line Area Competition and tent pitching competitions. The tent pitching would invariably be carried out on the first day of camp.

6. Each officer detailed in the Board of Officers will assess the contingents independently. Thereafter average marks of the board will be arrived at and submitted to OIC competitions as the final marks.

7. The contingent securing first place in this Competition will be awarded the Inter Directorate Line Area Competition Trophy.

**Criteria for Assessment**

8. The following will be the criteria for assessment of Line Area: -

<b><u>SNo</u></b>	<b><u>Assessment Criteria</u></b>	<b><u>Marks</u></b>
(a)	General layout of the area (As per enclosed sketch), hygiene and cleanliness & arrangement for refuse disposal(dustbin & its use).	15
(b)	Display of various orders, both in the English and in Hindi (Camp Fire Fighting, Standing & Routine Orders).	05
(c)	Correct layout, maintenance and serviceability of fire fighting eqpt	10
(d)	Correct and uniform kit layout.	05
(e)	Use of kit and equipment and its maintenance.	05
<b>TOTAL</b>		<b>50</b>

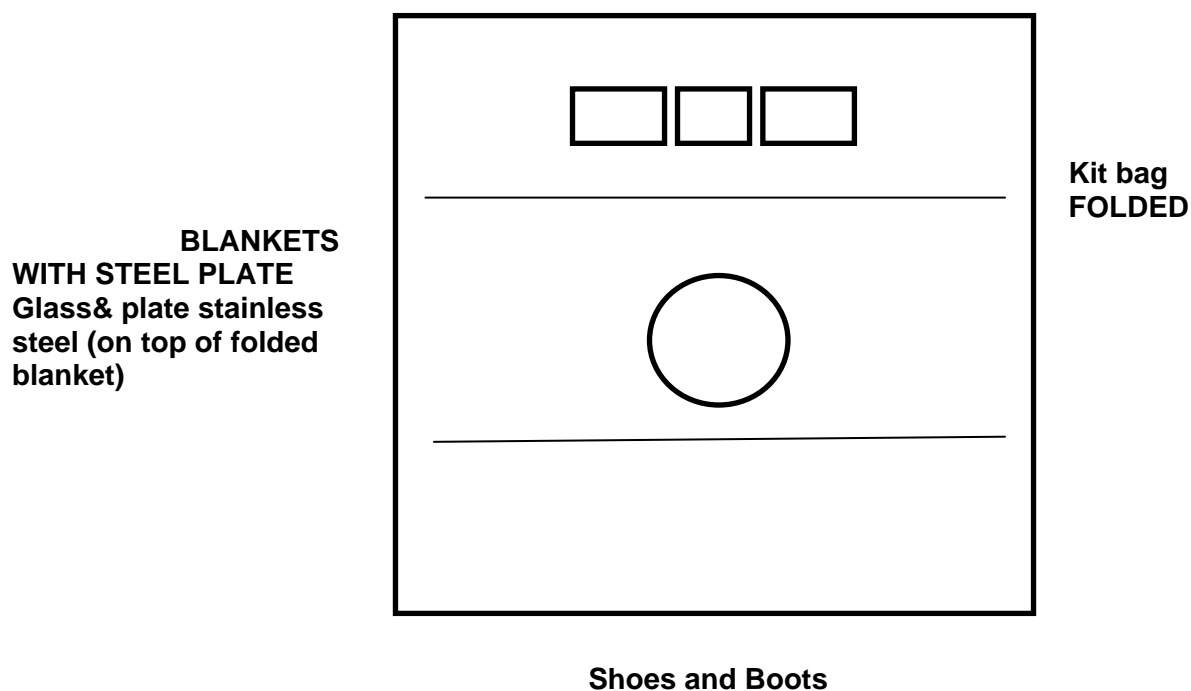

**SKETCH SHOWING LAYOUT OF ITEMS ON/UNDER THE COT****Top View****Notes:**

1. Stainless steel glass & plate be displayed.
2. A 'bed card' will be displayed on each kit. No photographs will be pasted on it.
3. Size of glass/plate/bed card will be standardized in each Directorate.
4. Notice Board & 'Snake bite kit' will be displayed.
5. Mirror and dustbin will be displayed.
6. The layout will be checked on all days throughout the camp except for the first two days when the camp is being set up and a day prior to the closing ceremony/prize distribution.

**Annexure B13****RULES FOR INTER DIRECTORATE HEALTH & HYGIENE  
COMPETITION AT AINSC**

1. **Aim.** To judge the knowledge of cadets in Health & Hygiene in order to promote professional skill involved in these subjects and thus making them useful citizens.
2. **Venue.** Competition will be held at Nau Sainik Camp.
3. **Composition of Directorate Team.** Two SD and SW cadets each will participate in the competition.
4. **Dress.** Uniform.
5. **Allocation of Marks.** These are as under: -
  - (a) Theory Examination - 40 marks

(b) Oral Examination - 10 marks

6. **Theory Examination.** The written examination will consist of an objective type and short answers question paper covering the syllabus for Health & Hygiene up to second year of training. The answer sheets will be evaluated by the team of officers' conducting the competition. The paper will be of approx. one hour duration.

7. **Oral Examination.** Cadets will also be examined by an oral test. The scope will include any of the topic(S) given in the syllabus for Health & Hygiene. The judge will decide the question bank for oral test prior to holding the competition. The topic for the oral test will remain the same for all teams.

8. **Judges for the Competition.** The judges for the competition will be nominated by DGNCC.

#### **Annexure B14**

### **RULES FOR INTER DIRECTORATE SAILING REGATTA COMPETITION**

1. **Introduction.** Sailing forms an important part of adventure training in the Naval Wing NCC. Sailing Regatta will be conducted at INS Chilka or at any Centrally Organised Camp as ordered by DG NCC. The aim of the sailing competition is to: -

- (a) To assess the level of proficiency achieved by various directorates.
- (b) To inculcate spirit of adventure and team spirit among the cadets.

2. **Crew.** Each Directorate will field team of 03 SD and 03 SW Naval Cadets including one reserve.

3. **Boat.** The race will be conducted in Enterprise Class / sailing Boats as ordered.

4. Participation of any team will be subject to the condition that a representative of DGNCC or Secretary Sailing club will assess the proficiency of the crew and decide whether the coxswain is sufficiently proficient to participate in the race in the interest of the safety of the crew. His decision will be final. The assessment will, however, be made by sailing the teams one by one or by running a short race. Boats thus disqualified, if any, shall run a race for deciding their intense position at the end of the event.

5. **Rules for Conduct of the Race.** The race will be conducted in accordance with International Yachting Racing Union(IYRU) Rules as promulgated from time to time. All Directorates may obtain copies of these Rules from the nearest office of the Yachting Association for their guidance. The detailed procedure to be followed for the conduct of the sailing race will be issued by Commanding Officer Nau Sainik Camp along with the Administrative Instructions for the Camp.

6. Results of the race will be intimated to the DGNCC by the Camp Commandant Points earned by each Directorate will count towards Republic Day Banner Competition.

7. The safety of the cadet is paramount and at no cost is to be compromised while dealing specially with the water borne activities. Camp Commandant is to adhere with safety precautions at Annexure B-6A in addition to the safety instructions issued from time to time. The team of the Directorate securing First Position will be awarded 100 points and

subsequent teams will be awarded points on a sliding scale with a difference of 2.50 points.  
**For example:** -

S.No	Position	Marks
(a)	First	100 points
(b)	Second	97.50 points (100 - 2.50)
(c)	Third	95.00 points (97.50 - 2.50)
(d)	Fourth	92.50 points (95.00 - 2.50) and so on with a difference of 2.5 between each position and the 17th position will get 60 points.

8. **Rig for the Crew.** The following rig is to be worn by the crew: -

S.No	Dress	S.No	Dress
(a)	White Shorts	(b)	Blue Socks
(c)	White Shirt	(d)	Inflatable Life Jackets
(e)	P.T. Shoes	(f)	Jersey (On order during cold weather)

9. **Protest.** Protest/objection/observations, if any, is to be lodged in writing within 30 minutes of completion/closing of the event.

10. **Results.** Results will be announced after disposing off protest/objections, if any.

11. **Prizes.** The inter-directorate sailing regatta trophy will be awarded to the winning directorate on the final day of Competition.

### **Guidelines on Safety and Security**

12. **Introduction.** The safety rules to be observed during the practices and the finals of Regatta are given in the succeeding paragraphs. These safety rules are the guidelines for the safety precautions to be observed by officers, PI staff and cadets participating in this Regatta. These rules are compiled from Seamanship Manual (BR 67) 1995 edition and various relevant sources.

13. Whilst every effort has been made to make these safety rules as comprehensive as possible to cover all contingencies, it is not possible to cover all contingencies in such situations. Therefore, personnel are advised to revert to advice/instructions tendered in Seamanship Manual (BR 67) and other relevant publications and the dictates of common sense as circumstances of the situation may warrant. Where, for some reasons, there has been a departure in these rules from those laid down in Seamanship Manual Vol I and II, the Seamanship Manual will supersede these instructions.

14. **Conditions of Boats and Fittings.** It is to be ensured that the boats designated as main and stand by for the regatta(boats and dinghies) are generally in overall good condition and there are no serious hull defects that may affect the seaworthiness of the boat during its employment during the Regatta. Special attention should be paid to the following aspects: -

(a) The hull should be waterproof to ensure that there is no possibility of ingress of water, which can, in any way, endanger its safety.

(b) All damaged items especially planks, keel box and buoyancy tanks etc are repaired properly and have been inspected.

(c) All the necessary fittings required for pulling and sailing, such as mast, sails, thwarts stretchers etc, are in state.

- (d) The bilge rails of boat and dinghies and the lifelines of boat are ok.
- (e) All the securing gear such as ringbolts, towing bollards, wires, ropes have been checked.
- (f) The rudder and its fittings are well secured and the tiller is provided with its split pin to ensure that it does not slip out whilst in use.
- (g) The plugs of the boats are properly fitted and the boat is watertight.

15. **Checking the Equipment.** Before taking out the whalers/dinghies for use during the practices/heats/regatta, coxswains is to ensure that the boat is correctly rigged. Coxswain is to doubly ensure the following: -

- (a) **Plug.** Is to be secured in its hold properly with no leakage.
- (b) **Oars.** Full complement of oars with one spare oar is to be ensured. It is particularly important that a dinghy equipped with only one pair of sculls should carry a spare oar.
- (c) **Crutches (Single-Banked Boats).** Full complement of oars with one spare to be ensured. Crutches are to be secured by its lanyard to the boat.
- (d) **Stretcher.** Is to be fitted in place for each thwart.
- (e) **Rudder.** Is to be shipped with lanyard secured to after ringbolt.
- (f) **Tiller.** Is to be shipped and secured with its split pin.
- (g) **Painter.** This is to be shackled to the stem ringbolt.
- (h) **Towing Bollard.** If portable, it is to be in the boat with its clamp & pin.
- (j) **Wearing of Life Jackets.** The crew is to wear half inflated Life jackets at all the time during sailing/pulling.

16. **Conduct of the Crew in the Boat.** When entering a boat, the crew should step on thwarts they should avoid stepping on the gunwale and move carefully in the boat. Movement of personnel in the boat must be kept to the absolute essential when underway. Even when the boat is alongside, movements inside the boat must be controlled and orderly. The crew member or passenger in the boat should not lean or rest any part of his body on the gunwale nor should any part of his body extend outside the hull of the boat except when specifically required to balance the boat during sailing.

17. **Loading of Boats.** The boat should not be loaded with personnel or material beyond the stipulated capacity. The maximum of personnel that may be embarked in boats is given below: -

- (a) Whaler - 10 Cadets
- (b) Dinghy - 03 Cadets

18. In addition to reducing loading to the number of personnel specified above, due heed must be paid to the positioning of personnel/material in the boat to ensure that the boat

remains on an even keel. Extra care while loading a boat is to be exercised so that boat does not become top heavy and therefore unstable.

19. **Precautions During Sailing.**

- (f) Sheets should be kept in hand and not belayed.
- (g) All the boat crew to wear half inflated life jackets at all the times while sailing/pulling.
- (h) When sailing, no one should stand on the thwarts or climb the mast.
- (i) If the gear is fouled aloft and cannot be cleared with a boat hook, crew must stand on the bottom boards while clearing the foul.
- (j) Alternatively, the sails is to be lowered to clear it.

20. **Handling in Rough Weather.** Attention of the coxswains is drawn to the condition that may occur during sailing in rough weather. The precautions and remedial action that should be taken as laid down under these headings in Seamanship Manual (BR 67) page 5-77 to 5-92. All the coxswains and crew are to be fully conversant with these actions and must be able to put them into practice if the situation warrants it.

21. **Drop Keel.** In a small boat, when keel is lowered, it lowers the center of gravity of the boat and make the boat more stabilized. When the keel is lowered, the resistance offered by the water to its surface reduces any tendency of the boat to roll but when the boat is under sail and making leeway, this lateral resistance will produce a capsizing movement. The movement is not appreciable under normal conditions of beating and reaching but may become dangerous if the boat is blown broadside to leeward by a sudden squall or if she yaws badly or broaches to when running. The drop keel should always be raised if there is chance of the boat running aground because if it hits the bottom not only might it become bent which might prevent it from being raised, it may also capsize the boat or even split her open.

22. **Safety Boat.** A minimum of one power boat should always remain available as safety boat during the conduct of the regatta. The safety boat should carry the following: -

- (a) One swimmer qualified in life saving.
- (b) Two life buoys.
- (c) Six spare life jackets.

23. **Safety Officer.** A safety and rescue officer is to be detailed by name by conducting Directorate. This officer will be responsible for ensuring safety during practices and during the Regatta.

24. **Conclusion.** The above rules are only general guidelines for the safety of these expeditions, they are by no means comprehensive and are to be read in conjunction with Manual of Seamanship (BR 67) 1995 edition and other relevant publications. Where there has been a departure in these rules from those laid down in the Manual of Seamanship 1995 edition, the Seamanship manual will supersede these instructions.

**RULES FOR INTER DIRECTORATE AIR WING COMPETITIONS**

1. **General** All India Vayu Sainik Camp (AIVSC) is essentially a centrally organised training camp for eligible Air Wing Cadets organised and conducted on behalf of Directorate Gen NCC. The aim of conduct of Air Wing Competitions is to: -

- (a) Assess Proficiency achieved by NCC Air Squadrons in all aspects of Air Wing training.
- (b) Assess conduct of Air Wing specialized training at respective Air Squadrons and Air Force specific awareness of participating cadets.
- (c) Inculcate a sense of Discipline, Leadership and Team Spirit.
- (d) Inculcate a sense of adventure and achievement involving a very high degree of precision and coordination.

2. **Conduct of Air Wing Competitions.**

(a) The Inter Directorate Air Wing Competitions shall be conducted during All India Vayu Sainik Camp (AIVSC) held in the month of October / November. **The competitions will contribute 70 RD Banner points.** The following events will be conducted towards RD banner:

<b><u>Event</u></b>	<b><u>Marks</u></b>
(i) Flying	: 1200
(ii) Aero Modelling	: 650
(iii) .22 Firing	: 200
(iv) Skeet Shooting	: 200
(v) Drill	: 200
(vi) Line Area	: 100
(vii) Health & Hygiene	: 100
<b>Total</b>	<b>: 2650 (to be reduced to 70 RD Banner Points)</b>

(b) **Air Wing Incentivising.** Considering additional impetus required to achieve desired flying training standards, **30 RD Banner points for Air Wing activities have been instituted.** These points will be allotted after assessment based on reports submitted to training Dte, which will be carried out over 100 points for each flying unit as per following sub heads:

<b><u>Event</u></b>	<b><u>Marks</u></b>
---------------------	---------------------

(i)	Number of SD / SW Cadets flown in MLs (min 3 sorties)	30
(ii)	Percentage of JD / JW Cadets flown in MLs (1 sortie)	15
(iii)	Aircraft Serviceability State (No of Days)	15
(iv)	Availability of Hanger, Infrastructure	05
(v)	Op Coordination with IAF / AAI	05
(vi)	Upkeep of Maintenance Facilities	05
(vii)	Flight Safety / Accident / Incident / Follow up of Col	05
(viii)	PRCN / Refresher Training of ANOs	05
(ix)	Performance of Cadets in NCC 'C' Certificate Exam	05
(x)	Submission of Monthly return through Dte	05
(xi)	Innovations / Flying Training Facilities	05
	<b>Total</b>	<b>100</b>

**Note:** 100 marks will be reduced to 30 RD Banner points. The above distribution of scores against each sub heads has been worked out based on realistic measures to facilitate Air Trg at each Air Wing NCC Unit level. In case of multiple Units in a Dte, the total scores will be prepared against each Flying Units and Dte score will be worked out as average of all Flying Units.

### **Flying: Best Pilot Competition (Boys & Girls)**

3. Flying competition will comprise of Ground Test (General Aviation Subjects & Type SOP on Virus SW 80 / Zen Air / X- Air) and Flying Test. Each Directorate will submit nominal roll of the Cadets and minimum 50% of the Cadets based on draw of lottery will appear for Ground Test. Cadets securing more than 50 % in each of the Ground Tests will participate in Flying Test. Flying Test will comprise of Checks & Procedure, Airmanship and Emergencies. The marks awarded will be out of maximum of 600, 200, 200 and 200 for Ground Test, Checks & Procedure, Airmanship and Emergencies respectively. Out of 600 marks towards Ground Test 400 marks are allotted for General Aviation Subjects and 200 marks for type SOP. Air Wing Specialised Training is to be imparted to all Air Wing Cadets and those selected for AIVSC are to be proficient in Air Wing Ground subjects.

### **Aero Modelling Competitions**

#### **4. Static Model (150 Marks)**

- (a) Two Cadets will participate in Static Model Competition.
- (b) Only One model (any type) of following scale to be brought to AIVSC without details / finish / colour:
  - Fighter / Bomber / Interceptor: Overall length 50 - 60 cm
  - Helicopter: Overall length without Main Rotor 50 - 60 cm
  - Transport / Executive ac: Wing span 50 - 60 cm
- (c) Scale will be assessed out of 50 marks
- (d) After assessment of scale, Cadets will be handed over the Models for finish, details, clarity and colour scheme which will be further assessed out of 75 marks.
- (e) Test / Viva on characteristics / performance / basic Aerodynamics of the Aeroplane / Helicopter out of 25 marks.

5. **Control Line Aerobatics Model (250 marks)**

- (a) Two Cadets will participate in Control Line Aero Model Competition.
- (b) Cadets will carry respective Model Kit and necessary tools for assembly & flying of Control Line Model. Readymade Models are not permitted.
- (c) **Assembly of CL Aerobatics Model: 100 marks**
- |   |                             |          |
|---|-----------------------------|----------|
| - | Scale/ Assembly             | 25 marks |
| - | Aerodynamic Characteristics | 25 marks |
| - | Finish                      | 25 marks |
| - | Test Flight                 | 25 marks |
- (d) **Flying of Model: 100 marks**
- |   |                       |          |
|---|-----------------------|----------|
| - | Take off              | 10 marks |
| - | Vertical climb / dive | 10 marks |
| - | 3 consecutive loops   | 30 marks |
| - | Inverted Flight       | 15 marks |
| - | Figure of Eight       | 15 marks |
| - | Landing               | 20 marks |
- (e) **Test / Viva on basic Aerodynamics / Flying Characteristics: 50 marks**

6. **Radio Controlled Power Model (250 marks)**

- (a) Two Cadets will participate in RC Power Aero Model Competition.
- (b) Cadets will carry respective Model Kit and necessary tools for assembly & flying of RC Power Model. Readymade Models are not permitted.
- (c) **Assembly of RC Power Model: 100 marks**
- |   |                              |          |
|---|------------------------------|----------|
| - | Scale/Assembly               | 25 marks |
| - | Aerodynamic Characteristics  | 25 marks |
| - | Finish, Integration of Radio | 25 marks |
| - | Test Flight                  | 25 marks |
- (d) **Flying of Model: 100 marks**
- |   |                             |          |
|---|-----------------------------|----------|
| - | Take off                    | 10 marks |
| - | 180 turn to one side        | 10 marks |
| - | Figure of Eight             | 20 marks |
| - | One Loop                    | 10 marks |
| - | Any one stunt               | 20 marks |
| - | Circuit, Approach & Landing | 30 marks |
- (e) **Test / Viva on flying characteristics: 50 marks**

**Inter Directorates Point 22 Firing Competition**

7. Total marks for .22 Firing will be 200. Grouping and snap shooting will be assessed out of 80 and 120 respectively. Each Directorate will nominate 04 SD and 02 SW cadets out of which 02 SD & 01 SW Cadets (By random selection) will participate. Each Cadet will participate in Grouping & Snap Shooting and Directorates score will be average of 03 participants.

- (a) **Grouping (Max 80):**



- Upto 2 Cms and below - 80 points
- 3 Cms - 72 points
- 4 Cms - 64 points
- 5 Cms - 56 points
- 6 Cms - 48 points
- 7 Cms - 40 points
- 8 Cms - 32 points
- 9 Cms - 24 points
- 20 Cms - 16 points
- 11 Cms - 08 points
- Above 11 Cms - NIL points

(b) **Snap Shooting (Max 120) 5 rounds each 24 points.**

#### **Inter Directorates Skeet Shooting Competition**

8. Each Directorate will nominate 02 SD & 02 SW Cadets for Skeet Shooting; out of which 01 SD & 01 SW (By random selection) will participate. Total marks for Skeet shooting will be 200 (100 each for SD & SW). 10 rounds of 10 points each will be fired apart from 02 practice rounds by each participant.

#### **Inter Directorates Drill Competition**

9. A total of 200 points are allotted for this event. The team will consist of 13 Cadets including Parade Commander (minimum one SW Cadet to participate).

10. The contingent will be formed in three ranks and four files. After permission from Judges, the Parade Commander will command the contingent for 'Khuli line chal' & 'Dahine saj' for inspection by Judges. After inspection, Drill will commence in following order: -

- (a) Dahine Mur, Baen Mur, Peeche Mur, Dahine / Baen Mur
- (b) Tej Chal, Peeche Mur, Samne salute (On the march)
- (c) Peeche Mur (After about 12 steps), Dahine / Baen Salute
- (d) Peeche Mur, Baen/ Dahine Salute, Tham
- (e) Baen / Dahine Mur, Samne Salute.

11. Arms drill will be carried out in following order:-

- (a) Bagal Shastra, Baju Shastra, Salami Shastra, Baju Shastra

(b) Bagal Shastra, Baen / Dahine Mur, Peeche Mur, Tej Chal

(c) Peeche mur (After about 15 steps), Tham, Dahine / Baen mur

12. Marking will be as under:

(a)	Turn Out, Dress, Smartness -	20
(b)	Static Movements -	20
(c)	Steadiness on Marching -	20
(d)	Movements on Marching -	40
	- Dahine / Baen & Peeche Mur (10)	
	- Samne, Baen & Dahine Salute (30)	
(e)	Static Movements (With Arms) -	25
(f)	Steadiness on Marching (With Arms) -	15
(f)	Movements on Marching (With Arms) -	20
(f)	Leadership & Word of Command -	30
(g)	Team Spirit & Josh -	10

---

**Total: 200**

### **Inter Directorates Line Area Competition**

13. A total of 100 points are allotted for this event including 20 points towards Tent pitching which will be held separately. The line area competition will be conducted in the area specified by Judges. All Cadets of the Directorates are to participate. The venue and time of the competition will be notified 24 hrs prior to conduct of competition. Marking for Line area and Tent pitching are as follows:-

(a)	General layout and cleanliness of the Area -	15
(b)	Display of various orders both in Eng & Hindi (Camp orders, fire fighting Orders, Routine orders, Security Orders etc)	10
(c)	Neat layout & Serviceability of Fire Fighting Eqpt	15
(d)	Fixing of tents, Entry Area decorum	15
(e)	Arrangement for throwing refuse	10
(f)	Kit layout, use of kit & eqpt and its maint	15
(g)	Tent Pitching (Held separately)	20

- 10 points upto 10 minutes or less. 01 mark will be deducted for every 30 seconds or part thereof, after 10 minutes.
- Neatness of Tent 05 marks,

- Kit Layout (04 kit) 05 marks)

### **Health & Hygiene Competition**

14. 02 SD & 02 SW Cadets (Drawn by random selection of all Cadets of the Directorates) from each Directorate will participate in Health & Hygiene competition. Total marks for Health & Hygiene will be 100.

- (a) Theory: 80 marks
- (b) Viva: 20 marks

### 15. **Recording, Declaration and Forwarding of Results.**

(a) The Directorate(s) and Camp staff nominated by DGNCC for the conduct the competitions will make all administrative and safety arrangements. Conduct of Competitions, Assessment, Compilation and Declaration of Results will be carried out by IAF Officers detailed by Air HQ/DGNCC.

(b) On conclusion of each individual event the detailed officer will record the results. Oi/c Competition will compile results of all events and event wise result sheets will be scrutinised and countersigned by the representative of DGNCC. Final result sheet will be countersigned by Camp Commandant.

(c) Protests, if any, during conduct of any competition, will be submitted in writing to Oi/c Competition along with Rs 1000/- (Rupees One Thousand only) within two hours. After detailed check on the matter, the Oi/c Competition will forward the same along with remarks to Rep of DGNCC for disposal. Decision of Rep of DGNCC will be final.

16. Following trophies will be awarded as per Directorates performance:-

- (a) Vayu Sena Trophy for Best Air Contingent
- (b) Vayu Sena Trophy for 2<sup>nd</sup> Best Air Contingent (Runners Up)
- (c) Best Directorates in Flying
- (d) Best Directorates in Aero Modelling
- (e) Best Directorates in Firing
- (f) Best Directorates in Drill
- (g) Best Directorates in Line Area

17. Following Medals (Gold, Silver, Bronze) will be awarded as per Individual performance;-

- (a) Flying (SD)
- (b) Flying (SW)
- (c) Static Aero Model

- (d) Control Line Aero Model
- (e) Radio Controlled Aero Model
- (f) .22 Firing (SD)
- (g) .22 Firing (SW)
- (h) Skeet Shooting (SD)
- (j) Skeet Shooting (SW)
- (k) Health & Hygiene (SD)
- (l) Health & Hygiene (SW)

18. **Eligibility for Participation in Air Wing Competitions.** Only Second / Third Cadets are permitted to participate in AIVSC. A Cadet is permitted to attend AIVSC only once. Squadron wise distribution of vacancies for SD/SW Air Wing cadets as intimated by DGNCC is to be strictly adhered to.

19. **Conversion to RD banner Points.** Following formula will be applied:-

- (a) **Air Wing Competitions.**  

$$\frac{\text{Total Marks Scored by a Directorate (para 2 (a) refers) x 70}}{2650}$$
- (b) **Air Wing Incentivisation**  

$$\frac{\text{Total Marks Scored by a Directorate (para 2 (b) refers) x 30}}{100}$$

### **Air Wing Display During RDC**

20. Air Wing Competitions towards RD banner are being held during AIVSC. Hence, no Air Wing Competitions are scheduled during RDC & PM's Rally.

21. In Order to motivate all participating Cadets of RDC towards Aviation related activities and display Air Wing activities to visiting dignitaries, Air Wing display consisting of Static Aero Models & Flying Aero Models prepared by NCC Air Wing Cadets during preceding AIVSC. Air Wing Display will be conducted in following manner.

- (a) **Static Aero Model.** 16 Static Aero Models build and assessed at preceding AIVSC will be displayed. Each Dte will bring the Static Model in a transparent case. Name of Dte is to be pasted on top right corner of the case when viewed from top. Placards to be made with details including leading particulars, performance, country of origin, roles on which the aero plane is employed, etc. In addition, Scale, Name of the Two Cadets who taught them making of the Model at their respective Unit / Dte is to be mentioned at the bottom of the placard. Placard holder is to be displayed on top of the case.
- (b) **Control Line Aerobatic Model.** 03 Control Line Aerobatic Models build and assessed as 1<sup>st</sup>, 2<sup>nd</sup> & 3<sup>rd</sup> in order of merit during preceding AIVSC to be brought to

RDC. Placard with mention of Dte, name of the Two Cadets who Instructor who prepared the Flying Model at preceding AIVSC location and name of the CO /Instructor who taught them making of the Flying Model at their respective Unit / Dte is to be mentioned at the bottom of the placard. Placard holder is to be displayed adjacent to the Model.

(c) Radio Controlled power Model. 03 Radio Controlled power Models buld and assessed as 1<sup>st</sup>, 2<sup>nd</sup> & 3<sup>rd</sup> in order of merit during preceding AIVSC to be brought to RDC. Placard with mention of Dte, name of the Two Cadets who Instructor who taught them making of the Flying Model at their respective Unit / Dte is to be mentioned at the bottom of the placard. Placard holder is to be displayed adjacent to the Model.

22. There is no change in total number of Air Wing Cadets participation in RDC as part of the Dte contingent. As there are no Aero Modeling completions during RDC, it is not mandatory to filed Aero Modeling Cadets as part of the Dte contingent. However, each Dte is to nominate on Air Wing Cadet with adequate communication skill and knowledge on Aeroplane particulars / Aerodynamics so as to brief dignitaries during Presentation / Display at NCC Republic Day Camp & PM's Rally.

**RULES FOR INTER DIRECTORATE ARMY WING**  
**COMPETITIONS: ALL INDIA THAL SAINIK CAMP (TSC) (BOYS)**

**General**

1. Inter Directorate Thal Sainik Camp (TSC) (Boys) will carry 50 points towards RD Banner and will be conducted during the TSC (Boys) along with Shooting Competition for SD and JD Cadets as per details given below:-

(a)	<b><u>All India Thal Sainik Camp (TSC) (Boys)</u></b>	<b><u>Strength of each Directorate</u></b>				<b><u>Points</u></b>		<b><u>Annexure</u></b>
		<b><u>SD</u></b>	<b><u>JD</u></b>	<b><u>Res</u></b>	<b><u>Total</u></b>	Total	RD Banner	
(i)	Obstacle Course	6	-	1	7	75	50	D1
(ii)	Map reading	6	-	1	7	75		D2
(iii)	Line & Tent Area	-	-	-	-	50		D3
(iv)	Health & Hygiene	4	-	1	5	50		D4
(v)	Judging Distance & Field Signal Competition	8	-	-	8	80		D5
	<b>Total</b>					330		

(b)	<b><u>Service Shooting Competition</u></b>	<b><u>Strength of each Directorate</u></b>				<b><u>Points</u></b>		<b><u>Annexure</u></b>
		<b><u>SD</u></b>	<b><u>JD</u></b>	<b><u>Res</u></b>	<b><u>Total</u></b>	Total	RD Banner	
(i)	SD	9	-	1	10	130		F1
(ii)	JD	-	6	1	7	90		F2
	<b>Total</b>					120		

2. In addition, events like 'guest lectures', Un armed combat/martial arts as self defense training, local treks, sight seeing and non-RD Banner competitions like 'cultural programme', 'poster competition', 'best cadet competition' etc., may also be included.

3. The Composition of TSC (Boys) contingent including participants for Inter Directorate Service Shooting Competition will be as under: -

(a) SD Boys - 33

(b) JD Boys - 7

4. (SD) participants for the Inter Directorate Shooting Competition (all wings) will be distinct from participants for TSC (Boys) including reserves and may take part only in either obstacle course or map reading competitions. However, as regards other three competitions Para 1 (a) (iv) (v) (vi), the strength will be drawn as given below:-

	<b><u>Nominated by Dte</u></b>	<b><u>Randomly Selected</u></b>
(a) Health and Hygiene Competition	01	04
(b) Line Area and Tent Pitching	All cadets	-
(c) Judging Distance and Field	02 (one each for JD & FS)	06

5. Trophies/Cups will be awarded to each Directorate who secure first position in each of the above-mentioned competitions. Similarly, for the individual position in each competition individual prizes will be announced. These individual prizes/merit certificates will be distributed during the Camp. They will have no bearing on the overall position of RD Banner. There will be a separate Trophy for Directorate for Inter directorate Shooting Competition. Director Training (A) will be responsible for procurement and handing over of the Prizes/Trophies/Merit-Certificates to the Camp Commandant. However, Inter Directorate Trophy will be awarded at the RD Camp.

### **Venue**

6. The event will be held as one of the Centrally Organised Camps. DG NCC/Training (A) will select venue in consultation with OIC Competitions & Secretary RDC keeping in mind the requirements of all the three competitions planned to be held during the Camp.

### **Composition**

7. Strength of teams for above competitions will be as indicated at Para 1 above.

### **Reserves**

8. All Cadets will take part in one of the sub competitions.

### **Submission of Nominal Rolls**

9. Directorates will submit the nominal rolls of their teams for each competition separately (including reserves) in triplicate to the Camp Commandant, who will hand over these to the Board of Officers conducting the competitions. These must be signed by the DDG of the concerned directorate or in his absence by the respective Directors. If the Camp Commandant does not receive nominal roll from any directorate by the due date he will call upon senior most Officer/PI Staff /Cadet of the concerned Directorate attending the camp to nominate the Directorate team. This team will be deemed to be the Official Team of that Directorate. Unforeseen changes, if any, will be authenticated by senior most representative of the Directorate, present in the camp.

### **Boards of Officers/Judges**

10. While administrative arrangements for the competitions will be made by the Camp Staff, the Competition will be conducted by a Board of Officers/Judges composed entirely of officers of DG NCC, OTA Kamptee and OTA Gwalior. PI Staff will also be nominated by Presiding Officer, out of Camp PI Staff, at random. Composition of the Board will be decided by OIC Competitions (DDG (MS)/DG NCC).

11. Also one of the DDsG (from HQ DG NCC) or Commandant of OTA Kamptee/Gwalior will be nominated by the DDG (MS), HQ DG NCC to oversee the conduct of competitions and give on the spot decisions in case of any dispute/protest. He will also be responsible to give his assessment on the standard displayed by the cadets and bring out any weaknesses noticed by the Board.

### **Declaration of the Results**

12. Results of each event will be finalized and signed by members of the Board of Officers and announced on the spot. Inter Directorate position will be announced later, but before the termination of the Camp (after all competitions are over).

13. Results duly signed by members of the Board of Officers and counter signed by the DDG detailed to supervise the competitions will be submitted to OIC Competitions, who will obtain approval of the DGNCC and send an authenticated copy to RD cell for dissemination to all Directorates.

### **Rules of Competitions**

14. These are contained in Annexure D1 – D5 referred to in Sub-Para 1 (a) above.

### **Administration**

15. Camp Commandant will be responsible to make following administrative arrangement for these competitions: -

- (a) Flags as indicated in rules for obstacle Course, Point-to-Point March and Shooting Competitions.
- (b) Targets as per details given out in the Shooting Competition Rules.
- (c) Service maps of the Competition Area.
- (d) Other Administrative arrangements i.e. seating, first aid, water/refreshment etc.
- (e) Transport.
- (f) Coordinating the date, time and the programme of competitions with OIC Competitions.

### **Dress & Equipment**

16. All cadets will be dressed in FSMO less pack 08 and will carry DP rifles (to be provided by Delhi Directorate) for all Army Wing Competitions less Shooting. However, Binocular, Pointer staff, Compasses and Map-case at the scale of two per Directorate will be brought by its Contingents.

17. Contents of Haversack will be as under: -

- (a) Towel Hand - One
- (b) Vest Cotton - One
- (c) Underwear Cotton - One
- (d) PT Shoes - One Pair
- (e) Soap with case - One
- (f) Toothpaste 50 gms - One
- (g) Tooth brush - One
- (h) Stainless Steel glass - One
- (j) Handkerchief- 2
- (k) Socks Black Nylon - One Pair
- (l) Boot laces black - One Pair
- (m) Housewife containing
  - (i) Thread White - One
  - (ii) Thread Khaki - One
  - (iii) Buttons White - Six (Shirts-3, Pant-3)
  - (iv) Buttons Khaki - Six (Shirts-3, Pant-3)
  - (v) Needles – Two
  - (vi) Safety Pins – six.



## INTER DIRECTORATE OBSTACLE COURSE COMPETITION

### Obstacle course

1. The obstacle course will consist of the following: -
  - (a) Straight Balance
  - (b) Clean Jump
  - (c) Gate Vault
  - (d) Zig Zag Balance
  - (e) High Wall
  - (f) Double Ditch
  - (g) Right Vault
  - (h) Left Vault
  - (j) Dam Dama
  - (k) Straight Balance

### Note.

- (a) Changes to above obstacles may be done depending on the availability of obstacle course.
- (b) The distance between the Start Line and the first obstacles will be 25 meters. The distance between the last obstacle and the Finish Line will be 25 meters.

### Conduct and Rules

2. It will be a team event and timed competition. Timings will be counted from the time the first member of the team crosses the start line till the last member of the team crosses the finish line. Dress for the competition will be Combat Dress with FSMO, less pack 08.

### Scoring

3. The team with the lowest average timing will be awarded maximum points, followed by other teams on the same criteria. In order to find the points scored by other Directorates, the following formula will be adopted: -

$$\frac{\text{Lowest total time in seconds taken by a team} \times 75}{\text{Next lowest time in seconds taken by a team}}$$

### Penalty Points

4. The following points will be deducted as penalty points from the score obtained:
  - (a) Not doing High Wall - 08 points
  - (b) Not doing Double Ditch - 06 points
  - (c) Not doing Zig Zag Balance – 04 points.
  - (d) Not doing any other obstacle - 02 points for every obstacle
  - (e) Any member not completing the course - 25 points

(f) Straight Balance & Zig-Zag Balance obstacle will have a white line marked 1 feet ahead of the further edge of the obstacle. Any cadet who does not clear this line will be penalised with 01 point.

5. Penalty timings will be levied on the team in case a cadet does not carry the entire kit of seventeen items in haversack as follows :-

- (a) 1 to 3 items deficient - 1 second will be added to the timing.
- (b) 4 to 6 items deficient - 2 seconds will be added to the timing.
- (c) 7 to 10 items deficient - 3 seconds will be added to the timing.
- (d) 11 or more items deficient - 4 seconds will be added to the timing.

6. In case cadets taking part in the competition are found to be having the water bottle 'not filled' during the competition, 0.5 second will be added to the timing per cadet, in addition to penalty imposed vide Para 5 above.

### **Administration**

7. Camp Commandant will be responsible for the complete arrangements for the competition. He will provide the following:-

- (a) JCOs - 4
- (b) PI Staff NCOs - 6
- (c) Red Flags (4' x 4') with poles - 2
- (d) White flags (4' x 4') with poles - 2
- (e) Nursing Assistant with First Aid Box - 1
- (f) Clip boards and Pencil - 6
- (g) Stop Watch - 2
- (h) Drinking Water - As required

8. OIC Competition will detail a Board of Officers to judge the competition. The Presiding Officer will submit the consolidated result to OIC competition within 24 hours of its completion.

9. Prior to the competition, a coordinating conference will be held. This will be chaired by DDG (MS) and attended by the Board of Officers and OIC teams.

## MAP READING COMPETITION

### Conduct and Rules

1. The aim of the competition is to test the grasping of the nuances of map reading by the cadets and translating the same on ground to identify the point and vice versa. Competition would be conducted in the morning from a vantage point. The strength of the team from each Dte will be 06 SD cadets and 01 reserve SD cadet.

2. Following tests would be conducted: -

- (a) Map to Ground
- (b) Ground to Map
- (c) Finding own position

3. Each cadet would get 04 min for GR of own loc and 03 min for GR of map to ground and ground to map pts.

### Scoring

4. The competition would carry a max of 75 marks. Detailed distribution of points is as under:-

- (a) Finding own position - 15 marks - 15 marks
- (b) Ground to Map (two points) - 15 marks each- 30 marks
- (c) Map to Ground (two points) - 15 marks each- 30 marks

5. Full marks would be given to an individual getting the GR within 100 m of the specified GR. For every 100 m beyond the specified GR 2 points would be deducted for each Easting/Northing.

6. Formula for team points.

Total points scored by team

No. of participants

7. **Team Position**. The team scoring max points would receive 75 points. The subsequent team would receive two points less i.e, First – 75, Second – 73, Third - 71 and so on.

8. **Selection of Site and Points**. Would be done under the supervision of Board of Officers. Board of Officers would select five points for Ground to Map and Map to Ground minimum 10 days before the competition. The same would be required to be approved by OIC Competitions.

### Administrative Arrangements

9. Camp Commandant would be responsible for the entire administrative arrangement of the competition. He would be responsible to provide the following: -

- (a) Seating arrangement at vantage point - Five 180 pounder outers with tarpaulin.
- (b) Drinking Water - As required

- (c) Medical officer and ambulance - One
- (d) Radio sets ANPRC 25 with operators - Two
- (e) Slips for writing GR - As required
- (f) JCOs - Five
- (g) PI Staff (NCOs) - Ten
- (h) Flag Red (4'x 4') - Two
- (j) Plastic Chairs - Twenty
- (k) Stop Watch - Two
- (l) Map Sets - 10 Per Directorate

10. A coordinating conference would be held one day prior to the competition under the chairmanship of DDG (MS). A Board of Officers would be detailed by OIC competition. The Board of Officers and OIC teams would be required to attend the conference.

11. Duly compiled results would be required to be submitted to OIC competition within 24 hrs after completion of the competition.

### **Annexure D3**

#### **RULES FOR LINE AREA COMPETITION**

##### **General**

1. The Line Area Competition will cover the line area of all Directorates. Venue of the competition will be Garrison Parade Ground, Delhi Cantt. This will carry 50 marks.

##### **2. Special Instructions**

- (a) No unauthorised and/or fancy items will be displayed in the Line Area. No credence will be given to un-military-like ostentatious/extravagant display of items.
- (b) For assessment, emphasis will be laid on hygienic living conditions, neatness, cleanliness and aesthetic appearance.
- (c) Directorates are not required to spend money on colourful marble chips and/or other fancy stores in front of the Line Area. These will not fetch any extra marks and may even invite penalty.
- (d) Directorates are not required to bring steel trunks for the cadets.

3. Each Team will establish a 'fire point' with the following items of fire fighting equipment at a convenient location: -

- (a) Fire extinguishers - 2
- (b) Fire hook & fire beater - 1 each
- (c) Buckets (sand) - 2
- (d) Buckets (water) – 2

4. The equipment displayed should be in serviceable condition. No extravagant display of non-essential equipment for fire fighting will be encouraged.

5. A board of officers will be detailed by OIC competitions to assess the Line Area Competition. Separate Board of Officers will be detailed for Boys and Girls area.

6. Each officer detailed in the Board of Officers will assess the Contingents independently. Thereafter average assessment of the board members will be arrived at and submitted to OIC Competitions as the final marks.

7. The contingent securing first place in this Competition will be awarded the Inter Directorate Line Area Competition Trophy.

### **Criteria for Assessment**

8. The following will be the criteria for assessment of Line Area (**Total 25**): -

- (a) General layout and cleanliness of Area (to include layout of cots, cleanliness of the barracks and adjoining areas, layout of other stores, kotes etc.) - 05
- (b) Display of various orders both in the English and Hindi (Camp Orders, Fire Fighting Orders, Routine Orders, Security Orders etc.) - 05
- (c) Neat layout, maintenance and serviceability of fire fighting equipment - 05
- (d) Arrangement for refuse disposal (Dustbin and its use) - 05
- (e) Correct and uniform kit layout, use of kit and equipment and its maintenance – 05

### **SKETCH SHOWING LAYOUT TOP VIEW OF ITEMS ON/UNDER THE COT**

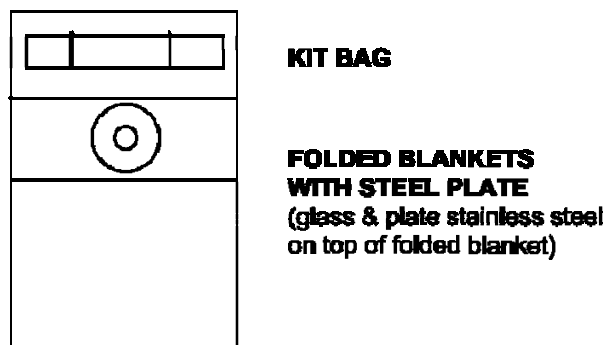

**(Shoes & Boots on sides of the bed)**

### **Notes :**

- (a) Stainless steel glass & plate be displayed.
- (b) A bed card will be displayed on each kit. No photograph will be pasted on it.
- (c) Size of glass/plate/bed card will be standardised in each Directorate.
- (d) Notice Board & Snakebite kit will be placed on left hand side (while facing main entry of the Barrack).
- (e) Mirror and dustbin on right hand side (while facing main entry of the Barrack).

9. The Camp Commandant and respective Officer-in-Charge Contingents will ensure that the general cleanliness is maintained in the Camp on a daily basis.

**TENT PITCHING COMPETITION (AS PART OF LINE AREA)**

10. Inter Directorate Tent Pitching competition will be conducted during TSC as part of the Line Area Inspection Competition. Modalities for the conduct of the competition are as under :-

- (a) One Tent Extendable (4M) will be pitched by each Directorate Team.
- (b) Participation. Eight cadets will participate, selected at random, a day prior to the conduct of competition, by the Board of Officer conducting the competition.
- (c) Conduct
  - (i) Lay out of Tents, frames and personal kit in the Assembly Area, in standard fashion, as dictated by the Presiding Officer.
  - (ii) Commence pitching of tent, by three Directorates teams at a time, at the earmarked plot, starting from the Start Line which will be one end of the Assembly Area.
  - (iii) Tent will be considered pitched and kits laid out only when all cadets of the Directorate's team fall back in the Assembly Area and a nominated senior cadet of the team report to the presiding officer by giving the following report. " \_\_\_\_\_ Directorate Tent is ready for your inspection, sir,"
- (d) Assessment. The assessment for the competition will be for 15 points, as under :-
  - (i) Time Taken. 05 points upto 08 minutes or less. Half mark will be deducted for every 30 seconds or part thereof, after 08 minutes.
  - (ii) Neatness of Tent Pitching\* - 05 marks .
  - (iii) Kit Layout (04 kits/Tents) - 05 marks. Layout will be same as that for cots in the Line Area inspections.

11. Aspects of coordination for the conduct of the competition will be included in the General Instructions for the competition. These will be issued by the presiding officer conducting the competition, 48 hours prior to the commencement of the competition.

\*Note - Neatness of Tent pitching will include the following :-

- (i) Correct assembling of frame and securing to the ground.
- (ii) Correct stretching of tent Outer and Inner covers over the frame.
- (iii) Spit locking of Snake trench of one foot width, at a distance of three feet from the outer edge of the tent on all sides, with lime. Aspects of coordination for the conduct of competition will be included in the general instructions for the competitions.

### **INTER DIRECTORATE HEALTH & HYGIENE COMPETITION**

#### **Aim**

1. To judge the knowledge of SD cadets in Health & Hygiene in order to promote professional skill involved in these subjects and thus making them useful citizens.

#### **Venue**

2. Competition will be held during TSC (Boys). Composition of Directorate Team.
3. Five Senior Division Cadets per Directorate, including one reserve.

#### **Dress**

4. Uniform.

#### **Allocation of Marks**

5. 50 point for the competition will be distributed as under: -

- (a) Theory Examination - 40 marks
- (b) Oral Examination - 10 marks

6. **Theory Examination.** The written examination will consist of an objective type and short answers question paper covering the syllabus for Health & Hygiene up to first year of training. The team of officers conducting the competition will evaluate the answer sheets. The paper will be of one-hour duration. The Presiding Officer will ensure use of Index Sheet while correcting papers, to ensure fair assessment.

7. **Oral Examination.** Cadets will also be assessed through an oral test. The scope will include any of the topic(s) given in the syllabus for Health & Hygiene. The judge will finalise the question bank for oral test prior to holding the competition. The topic for the oral test will remain the same for all teams.

#### **Judges for the Competition**

8. DDG (MS) will detail Board of Officers from officers of DGNCC/OTA Gwalior / Kamptee. Medical Officer from recognized Govt/Army Hospitals may also be detailed.

### **JUDGING DISTANCE AND FIELD SIGNAL COMPETITION**

#### **Aim**

1. The aim of the competition is to test the cadets in the specialized subjects of Field Craft and Battle Craft.

## **Conduct and Rules**

2. During the competition 160 points will be later reduced to 80 marks and will be conducted in two parts as under :-

- (a) Part I Written Test - 40
- (b) Part II Practical
  - (i) Judging Distance 60
  - (ii) Field Signal 60

## **Participation**

3. A total of eight cadets will participate. All cadets will participate in Written Test. For Practical Test, however, out of eight cadets, four cadets each will participate in Judging Distance and Field Signal. Six cadets for this competition would be selected randomly, One cadet each for Judging Distance and Field Signal for Part II of the competition will be nominated by respective Dtes. These cadets will be distinct from those selected for Tent pitching and Health & Hygiene competition.

4. The competition will be conducted on one day at a suitable field location where, both parts of the tests would be held, as under:-

(a) Part-I Written Test will be conducted first, for a duration of 45 minutes. The paper will consist of two sections as under:-

- (i) Section A Subjective Questions 20 Marks
- (ii) Section B Objective Questions 20 Marks

(b) Part-II Practical test will be conducted simultaneously for Field Signal and Judging Distance with 4 cadets per Dte being tested in each. The assessing Board of Officers will split itself into two groups and both, Judging Distance and Field Signal Test will be conducted simultaneously with half the Dtes being tested in one test and the other half in the other. Conduct will be as under:-

(i) Judging Distance. Cadets will be tested Dte wise, as per the sequence decided randomly by the Presiding Officer, on the spot. Each cadet will be asked to judge the distance of three objects, one each in Far, Middle and Near distance. Maximum marks for correct judgment will be 5 per point. Penalty for incorrect judgment will be awarded as under:-

(aa) For Distance. Full points for upto  $\pm 200$  meters in judgment. Minus one point for incorrect judgment of every  $\pm 200$  meters after that.

(ab) Middle Distance. Full points upto  $\pm 200$  meters in judgment. Minus one point for incorrect judgment of every +100 meters thereafter.

(ac) Near Distance. Full points upto  $\pm 50$  meters in judgment. Minus one point for incorrect judgment of every  $\pm 50$  meters.

(ii) Field Signal. All cadets will be tested Dte wise, as per the sequence decided randomly by the Presiding Officer, on the spot. Each cadet will be asked to indicate three different Field Signals. 5 points will be awarded for correct description of each signal. Thus four cadets will be judged out of 15 points each and total out of 60 points for each Dte (15 points each for four cadets).



5. The total assessment out of 160 points for Part I and Part II for each Dte will be reduced by half, to arrive at assessment out of 80 marks.

6. **Selection of Site and Points**. Would be done under the supervision of Board of Officers, Boards of Officers would select points on ground minimum 10 days before the competition. The same would be required to be approved by OIC Competitions.

### **Administrative Arrangements**

7. Camp Commandant will be responsible for entire administrative arrangement of the competition. He would be responsible to provide the following :-

- (a) Seating Arrangement at the vantage point - Five Tent Extendable with tarpaulin
- (b) Drinking Water - As required
- (c) JCOs - Five
- (d) PI Staff (NCOs) - Ten
- (e) Flag (4x4) All colours - Twenty
- (f) Plastic Chairs - Twenty
- (g) Stop Watch – Two

8. A coordinating conference would be held one day prior to the competition under the Chairmanship of DDG (MS). A Board of Officers would be detailed by OIC competition. The Board of Officers and OIC team would be required to attend the conference.

9. Duly compiled results would be required to be submitted to OIC competitions within 24 hrs after completion of the competition.

**RULES FOR INTER DIRECTORATE ARMY WING COMPETITIONS**  
**ALL INDIA THAL SAINIK CAMP (TSC) (GIRLS)**

**General**

1. Inter Directorate Girls Wing Competitions i.e., Thal Sainik Camp (TSC) (Girls), will carry 550 points towards the competitions and 50 points towards RD Banner and will be conducted during TSC (Girls). Shooting competitions for SW and JW cadets will be conducted in addition to Girls Wing Competitions during TSC and points will be added towards Inter Directorate Shooting competition. The details are given below:-

(a)	<b><u>All India Thal Sainik Camp (TSC) (Girls)</u></b>	<b><u>Strength of each Directorate</u></b>				<b><u>Points</u></b>		<b><u>Annexure</u></b>
		<b><u>SW</u></b>	<b><u>JW</u></b>	<b><u>Res</u></b>	<b><u>Total</u></b>	Total	RD Banner	
(i)	Health & Hygiene	4		1	5	50	50	E1
(ii)	Line & Tent Area	-		-	-	40		E2
(iii)	Map reading	5		1	6	75		E3
(iv)	Obstacle Course	5		1	6	75		E4
(v)	Judging Distance & Field Signal Competition	8		-	8	80		E5
	<b>Total</b>					<b>320</b>		

(b)	<b><u>Service Shooting Competition</u></b>	<b><u>Strength of each Directorate</u></b>				<b><u>Points</u></b>		<b><u>Annexure</u></b>
		<b><u>SW</u></b>	<b><u>JW</u></b>	<b><u>Res</u></b>	<b><u>Total</u></b>	Total	RD Banner	
(i)	SW	6	-	2	8	90		F2
(ii)	JW	-	6	2	8	90		F2
	<b>Total</b>					<b>180</b>		

**Note:**

(a) Participants for Inter Directorate Shooting Competition (All Wings) will be distinct from participants for TSC (Girls). Points scored in Inter Directorate Shooting Competition (All Wings) will be accounted for as per Appendix 'F'.

(b) No Cadet will take part in more than one competition listed at Sub-Para 1(a) (i), 1(a) (iii), 1(a) (iv) & 1(a)(v).

(c) All cadets may participate in Line Area Competition.

(d) Two Cadets one each for JD and FS (Part II Practical) will be nominated by respective Directorates and six cadets will be selected randomly for the competition.

2. Maximum marks will be awarded out of 50 to each cadet, for Health & Hygiene, 75 marks each for Map Reading & Obstacle competitions, 100 marks for Advance Shooting Competition. Marks scored by each cadet will be added to arrive at the average marks obtained by their respective Directorates for these competitions out of 50, 75 and 100 points

respectively. Marks obtained by a Directorate in Line Area Competition will also be added to arrive at the total points obtained by a Directorate out of 370. Directorates will thereafter be awarded points out of 50 to count towards the RD Banner.

3. However, for the purposes of trophies/cups for the above competitions, position of first three Directorates will be worked out. Similarly, for purposes of individual prizes, first three individual positions for each competition will be announced. Those positions will have no bearing on RD Banner Championship.

### **Venue**

4. The Competition will be held during TSC (Girls).

### **Dress**

5. Uniform

### **Composition of Contingent**

6. The composition of Directorate contingents for TSC (Girls) including participants for Inter Directorate Shooting Competition (all Wings), will be as follows:

(a) SW Girls - 32

(b) JW Girls - 08

7. Strength of teams for the above competitions will be as enumerated at Para 1 above. Teams will be constituted as per the policy on random selection elucidated in this book.

### **Submission of Nominal Rolls**

8. Directorates will submit the nominal roll of their contingent in triplicate to the Camp Commandant, who in turn will hand these over to the Board of Officers conducting the competitions. These must be signed by respective State DDsG or in their absence by the Directors. If Camp Commandant does not receive the nominal roll of any Directorate by due date, he will call upon senior most Officer/PI Staff/Cadet of that Directorate attending the camp to nominate the Directorate team. The team so nominated will be deemed to be the official team of that Directorate.

### **Boards of Officers /Judges**

9. All administrative arrangements for the competitions will be made by the Camp Staff. A Board of Officers/Judges comprising entirely of officers of HQ DGNCC and OTA Kamptee/Gwalior will conduct the competitions. However, for Health and Hygiene competitions, Doctors from hospitals may be co-opted as members/Judges. Presiding Officers will also nominate PI Staff. Composition of the Board will be approved by OIC Competition {DDG (MS), DGNCC}.

10. In addition, one of the DDsG of DGNCC or Commandants OTA Gwalior/Kamptee will be nominated by the DDG MS, DG NCC to oversee the conduct of competitions, who will give on the spot decisions in case of any dispute/ protest.

**Declaration of Results**

11. Results of each event towards award of individual prizes (1st, 2nd and 3rd) will be finalized and signed by the Board of Officers. Inter Directorate position will be determined after compiling the scores of all Directorates in the six competitions.

12. Results, duly signed by members of the Board of Officers and countersigned by DDG detailed to supervise, will be submitted to OIC Competitions. He will obtain approval of the DG NCC and forward the authenticated copy to RD Cell for dissemination to all the directorates.

**Rules of Competitions**

13. The rules of the competitions are as enumerated at Annexure E1 to E6.

**Administration**

14. The Camp Commandant will be responsible to make all administrative arrangements for the conduct of the competitions including the following: -

- (a) Layout of furniture/equipment.
- (b) Transport for judges and cadets.
- (c) Arrangements for tea and light refreshments.
- (d) Stop Watches.
- (e) Any other stores/ Equipment required by judges to meet any short fall.
- (f) Co-ordinate the date and time and programme of competition with OIC Competitions.

**Annexure E1**

**INTER DIRECTORATE HEALTH & HYGIENE COMPETITION****Aim**

1. To judge the knowledge of SW cadets in Health & Hygiene in order to promote professional skill involved in these subjects and thus making them useful citizens.

**Venue**

2. Competition will be held at TSC (Girls).

**Composition of Directorate Team**

3. Five Senior Wing Cadets per Directorate, including one reserve.

**Dress**

4. Uniform.

**Allocation of Marks**

5. These are as under: -

- (a) Theory Examination - 40 marks
- (b) Oral Examination - 10 marks

6. **Theory Examination**. The written examination will consist of an objective type and short answers question paper covering the syllabus for Health & Hygiene up to first year of training. The team of officers conducting the competition will evaluate the answer sheets. The paper will be of one-hour duration. The Presiding Officer will ensure use of Index Sheet while correcting papers, to ensure fair assessment.

7. **Oral Examination**. Cadets will also be assessed through an oral test. The scope will include any of the topic(s) given in the syllabus for Health & Hygiene. The judge will finalise the question bank for oral test prior to holding the competition. The topic for the oral test will remain the same for all teams.

**Judges for the Competition**

8. DDG (MS) will detail Board of Officers from officers of DGNCC/OTA Gwalior/Kamptee. Medical Officer from recognized Govt/Army Hospitals may also be detailed.

**Annexure E2**

**RULES FOR LINE AREA COMPETITION****General**

1. The Line Area Competition will cover the line area of all Directorates participating in TSC (Girls). Venue of the competition will be Garrison Parade Ground, Delhi Cantt. This will carry 50 marks.

2. **Special Instructions**.

- (a) No unauthorised and/or fancy items will be displayed in the Line Area. No credence will be given to un-military-like ostentatious/extravagant display of items.
- (b) For assessment, emphasis will be laid on hygienic living conditions, neatness/cleanliness and aesthetic appearance.
- (c) Directorates are not required to spend money on colourful marble chips and/or other fancy stores in front of the Line Area. These will not fetch any extra marks and may even invite penalty.
- (d) Directorates are not required to bring steel trunks for the cadets.

3. Each Team will establish a 'fire point' with the following items of fire fighting equipment at a convenient location: -

- (a) Fire extinguishers - 2
- (b) Fire hook & fire beater - 1 each
- (c) Buckets (sand) - 2
- (d) Buckets (water) - 2

4. The equipment displayed should be in serviceable condition. No extravagant display of non-essential equipment like CGI sheet/plastic shed for fire fighting equipment will be encouraged.
5. A board of officers will be detailed by OIC competitions to assess the Line Area Competition.
6. Each officer detailed in the Board of Officers will assess the Contingents independently. Thereafter average assessment of the board members will be arrived at and submitted to OIC Competitions as the final marks.
7. The contingent securing first place in this Competition will be awarded the Inter Directorate Line Area Competition Trophy separately for TSC (Girls).

### **Criteria for Assessment**

8. The following will be the criteria for assessment of Line Area (**Total 25**): -
  - (a) General layout and cleanliness of Area (to include layout of cots, cleanliness of the barracks and adjoining areas etc.) - 05
  - (b) Display of various orders both in the English and Hindi (Camp Orders, Fire Fighting Orders, Routine Orders, Security Orders etc.) -05
  - (c) Neat layout, maintenance and serviceability of fire fighting equipment - 05
  - (d) Arrangement for refuse disposal (Dustbin and its use) - 05
  - (e) Correct and uniform kit layout, use of kit and equipment and its maintenance - 05

### **SKETCH SHOWING LAYOUT TOP VIEW OF ITEMS ON/UNDER THE COT**

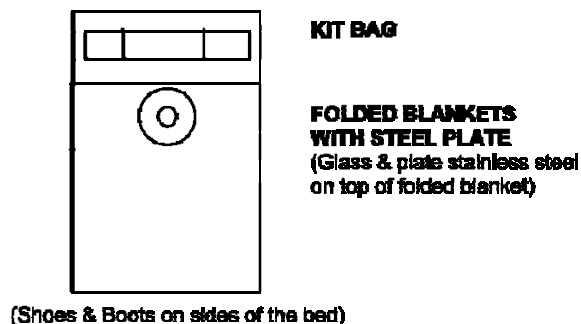

### **Notes**

- (a) Stainless steel glass & plate be displayed.
- (b) A bed card will be displayed on each kit. No photograph will be pasted on it.
- (c) Size of glass/plate/bed card will be standardized in each Directorate.
- (d) Notice Board & Snake bite kit on left hand side (while facing main entry of the Barrack).

(e) Mirror and dustbin on right hand side (while facing main entry of the Barrack).

9. The Camp Commandant and respective Officer-in-Charge Contingents will ensure that the general cleanliness is maintained in the Camp on a daily basis.

### **TENT PITCHING COMPETITION**

10. Inter Directorate Tent Pitching competition will be conducted during TSC as part of the Line Area Inspection Competition. Modalities for the conduct of the competition are as under :-

(a) One Tent Extendable (4M) will be pitched by each Directorate Team.

(b) Participation. Eight cadets will participate, selected at random, a day prior to the conduct of competition, by the Board of Officer conducting the competition.

(c) Conduct.

(i) Lay out of Tents, frames and personal kit in the Assembly Area, in standard fashion, as dictated by the Presiding Officer.

(ii) Commence pitching of tent, by three Directorates teams at a time, at the earmarked plot, starting from the Start Line which will be one end of the Assembly Area.

(iii) Tent will be considered pitched and kits laid out only when all cadets of the Directorate's team fall back in the Assembly Area and a nominated senior cadet of the team report to the presiding officer by giving the following report. "\_\_\_\_\_ Directorate Tent is ready for your inspection, sir,"

(d) Assessment. The assessment for the competition will be for 15 points, as under:-

(i) Time Taken. 05 points upto 08 minutes or less. Half mark will be deducted for every 30 seconds or part thereof, after 08 minutes.

(ii) Neatness of Tent Pitching\* - 05 marks .

(iii) Kit Layout (04 kits/Tents) - 05 marks. Layout will be same as that for cots in the Line Area inspections.

11. Aspects of coordination for the conduct of the competition will be included in the General Instructions for the competition. These will be issued by the presiding officer conducting the competition, 48 hours prior to the commencement of the competition.

\*Note - Neatness of Tent pitching will include the following :-

(i) Correction assembling of frame and securing to the ground.

(ii) Correct stretching of tent Outer and Inner covers over the frame.

(iii) Spit locking of Snake trench of one foot width, at a distance of three feet from the outer edge of the tent on all sides, with lime. Aspects of coordination for the conduct of competition will be included in the general instructions for the competitions.

### **MAP READING COMPETITION: TSC (GIRLS)**

#### **Conduct and Rules**

1. The aim of the competition is to test the grasping of the nuances of map reading by the cadets and translating the same on ground to identify the point and vice versa. Competition would be conducted in the morning from a vantage point. The strength of the team from each Dte will be 01 SW cadets and 02 reserve SW cadets.

2. Following tests would be conducted : -

- (a) Map to Ground
- (b) Ground to Map
- (c) Finding own position

3. Each cadet. 04 min to find GR of own position 03 min to find GR of map to ground and ground to map pts.

#### **Scoring**

4. The competition would carry a max of 75 marks. Detailed distribution of points is as under:-

- (a) Finding own position - 15 marks - 15 marks
- (b) Ground to Map (two points) - 15 marks each- 30 marks
- (c) Map to Ground (two points) - 15 marks each- 30 marks

5. Full marks would be given to an individual getting the GR within 100 m of the specified GR. For every 100 m beyond the specified GR 2 points would be deducted for each Easting/Northing.

6. Formula for team points.

Total points scored by team

No. of participants

7. **Team Position**. The team scoring max points would receive 75 points. The subsequent team would receive two points less i.e. First – 75, Second – 73, Third - 71 and so on.

8. **Selection of Site and Points**. Would be done under the supervision of Board of Officers. Board of Officers would select five points for Ground to Map and Map to Ground minimum 10 days before the competition. The same would be required to be approved by OIC Competitions.

#### **Administrative Arrangements**

9. Camp Commandant would be responsible for the entire administrative arrangement of the competition. He would be responsible to provide the following: -

- (a) Seating arrangement at vantage point - Five 180 pounder outers with tarpaulin.



- (b) Drinking Water - As required
- (c) Medical officer and ambulance - One
- (d) Radio sets ANPRC 25 with operators - Two
- (e) Slips for writing GR - As required
- (f) JCOs - Five
- (g) PI Staff (NCOs) - Ten
- (h) Flag Red (4'x 4') - Two
- (j) Plastic Chairs - Twenty
- (k) Stop Watch - Two
- (l) Map Sets - 10 Per Directorate

10. A coordinating conference would be held one day prior to the competition under the chairmanship of DDG (MS). A Board of Officers would be detailed by OIC competition. The Board of Officers and OIC teams would be required to attend the conference.

11. Duly compiled results would be required to be submitted to OIC competition within 24 hrs after completion of the competition.

#### **Annexure E4**

### **INTER DIRECTORATE OBSTACLE COURSE COMPETITION FOR SW GIRLS**

#### **Obstacle course**

1. The obstacle course will consist of the following: -

- (a) Straight Balance
- (b) Clean Jump
- (c) Gate Vault
- (d) Zig Zag Balance
- (e) Right Vault
- (f) Left Vault
- (g) Dam Dama
- (h) Straight Balance

#### **Note.**

- (i) Changes to above obstacles may be done depending on the availability of obstacle course.
- (ii) The distance between the Start Line and the first obstacles will be 25 meters. The distance between the last obstacle and the Finish Line will be 25 meters.

#### **Conduct and Rules**

2. It will be a team event and timed competition. Team will consist of five SW cadets. One cadets will be reserve. Timings will be counted from the time the first member of the team crosses the start line till the last member of the team crosses the finish line. The competition will be held in single belt without weapon. Cadets may wear either the combat uniform or khaki uniform.

#### **Scoring**

3. The team with the lowest average timing will be awarded maximum points, followed by other teams on the same criteria. In order to find the points scored by other Directorates, the following formula will be adopted: -

$$\frac{\text{Lowest total time in seconds taken by a team} \times 75}{\text{Next lowest time in seconds taken by a team}}$$

### **Penalty Points**

4. The following points will be deducted as penalty points from the score obtained:

- (a) Failure to cross Zig-Zag Balance - 04 points
- (c) Member of a team fails to cross any other obstacle - 02 points
- (c) Any member not completing the course - 25 points
- (d) Straight Balance & Zig-Zag Balance obstacles will have a whiteline marked 01 Ft ahead of the farther edge of the obstacle. Any cadet who does not clear this line will be penalised 01 point.

### **Administration**

5. Camp Commandant will be responsible for the complete arrangements for the competition. He will provide the following: -

- (a) JCOs - 2
- (b) PI Staff NCOs - 4
- (c) Red Flags (4' x 4') with poles - 2
- (d) White flags (4' x 4') with poles - 2
- (e) Nursing Assistant with First Aid Box - 1
- (f) Clip boards with Pencil - 6
- (g) Stop Watch - 3
- (h) Drinking Water - As required

6. OIC Competition will detail a Board of Officers to judge the competition. The Presiding Officer will submit the consolidated result to OIC competition within 24 hours of its completion.

7. Prior to the competition, a coordinating conference will be held. This will be chaired by DDG (MS) and attended by the Board of Officers and OIC teams.

## **Annexure E5**

### **JUDGING DISTANCE AND FIELD SIGNAL COMPETITION**

#### **Aim**

1. The aim of the competition is to test the cadets in the specialized subjects of Field Craft and Battle Craft.

Conduct and Rules

2. The competition will be conducted for 160 & then reduced to 80 marks for TSC in two parts as under :-

- (a) Part I Written Test 40
- (b) Part II Practical
  - (i) Judging Distance 60
  - (ii) Field Signal 60

### **Participation**

3. A total of eight cadets will participate. All cadets will participate in Written Test. For Practical Test, however, out of eight cadets, four cadets each will participate in Judging Distance and Field Signal. Six cadets for this competition would be selected randomly, One cadet each for Judging Distance and Field Signal for Part II of the competition will be nominated by respective Dtes. These cadets will be distinct from those selected for Tent pitching and Health & Hygiene competition.

4. The competition will be conducted on one day at a suitable field location where, both parts of the tests would be held, as under:-

(a) Part-I Written Test will be conducted first, for a duration of 45 minutes. The paper will consist of two sections as under:-

- (i) Section A Subjective Questions 20 Marks
- (ii) Section B Objective Questions 20 Marks

(b) Part-II Practical test will be conducted simultaneously for Field Signal and Judging Distance with 4 cadets per Dte being tested in each. The assessing Board of Officers will split itself into two groups and both, Judging Distance and Field Signal Test will be conducted simultaneously with half the Dtes being tested in one test and the other half in the other. Conduct will be as under:-

(i) Judging Distance. Cadets will be tested Dte wise, as per the sequence decided randomly by the Presiding Officer, on the spot. Each cadet will be asked to judge the distance of three objects, one each in Far, Middle and Near distance. Maximum marks for correct judgment will be 5 per point. Penalty for incorrect judgment will be awarded as under:-

(aa) For Distance. Full points for upto  $\pm 200$  meters in judgment. Minus one point for incorrect judgment of every  $\pm 200$  meters after that.

(ab) Middle Distance. Full points upto  $\pm 200$  meters in judgment. Minus one point for incorrect judgment of every  $\pm 100$  meters thereafter.

(ac) Near Distance. Full points upto  $\pm 50$  meters in judgment. Minus one point for incorrect judgment of every  $\pm 50$  meters.

(ii) Field Signal. All cadets will be tested Dte wise, as per the sequence decided randomly by the Presiding Officer, on the spot. Each cadet will be asked to indicate three different Field Signals. 5 points will be awarded for correct description of each signal. Thus four cadets will be judged out of 15 points each and total out of 60 points for each Dte (15 points each for four cadets).

5. The total assessment out of 160 points for Part I and Part II for each Dte will be reduced by half, to arrive at assessment out of 80 marks.

6. **Selection of Site and Points**. Would be done under the supervision of Board of Officers, Boards of Officers would select points on ground minimum 10 days before the competition. The same would be required to be approved by OIC Competitions.

### **Administrative Arrangements**

7. Camp Commandant will be responsible for entire administrative arrangement of the competition. He would be responsible to provide the following :-

- (a) Seating Arrangement at the vantage point - Five Tent Extendable with tarpaulin.
- (b) Drinking Water - As required.
- (c) JCOs - Five
- (d) PI Staff (NCOs) - Ten
- (e) Flag (4x4) All colours - Twenty
- (f) Plastic Chairs - Twenty
- (g) Stop Watch – Two

8. A coordinating conference would be held one day prior to the competition under the Chairmanship of DDG (MS). A Board of Officers would be detailed by OIC competition. The Board of Officers and OIC team would be required to attend the conference.

9. Duly compiled results would be required to be submitted to OIC competitions within 24 hrs after completion of the competition.

**RULES FOR INTER DIRECTORATE SHOOTING  
COMPETITION (ALL WINGS)**

**General**

1. Inter Directorate Shooting Competition (All Wings) will be of 400 marks, which will subsequently be scaled down to 75 points towards the RD Banner. Armourer of the participating directorate may be present at the firing point. Details regarding level of participation and allocation of marks are given below: -

	<b><u>Service Shooting Competition</u></b>	<b><u>Strength of each Directorate</u></b>				<b><u>Points</u></b>		<b><u>Annexure</u></b>
		<b><u>SW</u></b>	<b><u>JW</u></b>	<b><u>Res</u></b>	<b><u>Total</u></b>	Total	RD Banner	
(a)	SD	09	-	01	10	130	75	F1
(b)	JD	-	06	01	07	90		F2
(c)	SW	06	-	02	08	90		F2
(d)	JW	-	06	02	08	90		F2
	Total					400		

**Venue**

2. Shooting competition will be held at Centrally Organised Camps namely, TSC (Boys) and TSC (Girls) held prior to annual RD Camp. Venue will be selected by DGNCC (Trg A), in consultation with OIC Competitions, where the requisite firing ranges are available.

**Dress**

3. Dress will be as mentioned in Annexures to these rules.

**Conduct**

4. Responsibility for conducting these competitions will be that of a Board of Officers detailed by OIC Competitions and composed entirely of officers from DGNCC/OTA Kamptee/Gwalior. A DDG from DGNCC will oversee each of these competitions and take decision on the spot in case of a dispute/protest. Presiding Officer will declare score of each category/Wing (Not Inter Directorate position) on the spot and submit the score sheet to OIC Competitions within 24 hrs. OIC Competitions will compile the overall Inter-Directorate position for whole of the shooting competition subsequently, once all the matches are over.

5. Camp Commandant will make the administrative and safety arrangements for the competition. Firing Point and Butt will be manned by a member of the Board of Officers constituted of members from DGNCC/OTA Kamptee/Gwalior or a 152 representative of Army/Police Unit to whom the Range belongs. Assistance of Camp PI Staff will, however, be made available to the Board of Officers, as and when required.

**Note.** Imported 0.22 ammunition may be used for the competition, however, the same will have to be catered for by the respective directorate.

### **Strength and Composition of Teams, Practices and Scoring.**

6. The details regarding strength & composition of teams, practices and scoring are given in Annexure F1 & F2.

### **Tie Breaker**

7. In case of a tie between firers for individual prizes (1st, 2nd and 3rd of each category) the following procedure will be adopted: -

(a) For Application and Snap Shooting. In the event of tie, all affected firers will be made to fire grouping practice applicable to their Wing/Division. Size of the group will be taken into consideration to decide the individual position. In case the tie still persists, it will be broken as indicated in succeeding Sub Para.

(b) For Grouping. All affected will fire the same practice again. In case tie still persists, the grouping will be fired again within one minute and later reduced by 10 seconds each time till the positions are decided.

### **Administration**

8. The Camp Commandant will be responsible for all the administrative arrangements including the following:-

(a) Range allotment and clearance. He will ascertain from OIC Competitions in advance, the dates on which range is required.

(b) Coordinating with OIC Competitions the date and programme of the competitions.

(c) Safety precautions including provision of sentries.

(d) Provision and proper distribution of ammunition.

(e) Arranging armourer with tools at the Firing Point.

(f) Provision of targets, flags, jackets and target patching material.

(g) Practicing the Competitors in Range Drill.

(h) Provision of Firing Point and Butt Registers.

(j) Buglers. Tele communication & Stop watch.

(k) Establishment of Kote and ammunition store in the Camp.

(l) First aid box and medical staff. He will also position an Ambulance vehicle at the Firing Range for the duration of the Competition.

(m) Transportation of cadets and stores to range and back.

9. **Prizes/Trophy.** Cadets securing 1st, 2nd and 3rd position in each competition will be awarded individual prizes before dispersal from the Camp where competition is held. Inter Directorate Shooting Trophy will be awarded at the TSC Camp where competition is conducted.

**RULES FOR SHOOTING COMPETITION FOR  
SENIOR DIVISION**

**Strength and Composition of Teams**

1. Each Directorate team will consist of nine SD cadets from any wing. In addition, one cadet will be as reserve. These cadets will be from within the total vacancies allotted for TSC (Boys) and selected at random as per policy. Three cadets per Directorate will fire each practice. Armourer of the participating Directorate may be present at the firing point. Armourer of the participating Directorate may be present at the firing point.

**Weapons**

2. Point 22 Mark III/Mark IV/Sporting/Deluxe Rifles will be used. Telescopic sights will not be used. The rifles will be properly zeroed before being brought to the Camp. During the journey the rifles will be carried by the PI Staff and not by the cadets. However, any Directorate team desirous to check zeroing of weapons of their cadets can do so before commencement of competition if such facilities are available.

**Ammunition**

3. The Camp Commandant will provide ammunition including for zeroing and warmer rounds out of the ammunition brought by the Directorates.

**Dress**

4. Terrycot/cotton uniforms, hat/cap FS/Pagri, pouches basic with attachment braces, web-belt, anklets web and boots ankle. Navy/Air Wing cadets, if participating, will also wear boots ankle.

**Practices**

5. Three practices of Grouping, Application and Snap Shooting will be fired as follows:-

(a) **Grouping.**

<u>Distance</u>	25 meters/ yards	
<u>Number of Rounds</u>	Five	
<u>Position</u>	Laying with rest	
<u>Target</u>	1' x 1' Grouping	
<u>Highest Points</u>	40	
<u>Time</u>	15 Minutes	
<u>Scoring</u>	2 cm and below	40 points
	2.5 cm and below	36 points
	3 cm and below	32 points
	3.5 cm and below	28 points
	4 cm and below	24 points
	4.5 cm and below	20 points
	5 cm and below	16 points
	5.5 cm and below	12 points
	6 cm and below	08 points
	6.5 cm and below	04 points
	Above 6 cm	00 points

(b) **Application.**

<u>Distance</u>	25 meters/ yards	
<u>Number of Rounds</u>	Five	
<u>Position</u>	Laying without rest	
<u>Target</u>	1' x 1' Application	
<u>Highest Points</u>	40	
<u>Time</u>	15 Minutes	
<u>Scoring</u>	Bull	8 points
	Inner	6 points
	Magpie	4 points
	Outer	2 points

(c) **Snap Shooting**

<u>Distance</u>	25 meters/ yards
<u>Number of Rounds</u>	Five
<u>Position</u>	Laying without rest
<u>Target</u>	Figure 11 miniature
<u>Highest Points</u>	50
<u>Time</u>	Five exposures of seven second each to be given at a regular interval over a period of 1.5 minutes. Interval between the exposures will not be less than six seconds. A trial exposure will be given to start with. Rifles may be loaded and firers may be in aimed position, before each exposure. Where facilities for pop up targets are not available, timings will be controlled from the firing point by means of a whistle. For subsequent fire, rifle will be loaded but not at aiming position. This will be raised only after the whistle is blown for each exposure.

**Warmer Rounds**

6. Two warmer rounds will be allowed at the beginning of the competition each day when the rifle is fired for the first time.

**Misfire/Stoppages**

7. In case of a misfire or stoppage, additional exposure/ammunition will be permitted only in snap shooting. But in case a competitor fails to fire within the laid down timings, no extra time exposure will be provided.

**Zeroing**

8. Directorate teams desirous of checking zeroing of weapons of their cadets can do so before commencement of the competition if facilities are so available.

**Award of Points to Directorates**

9. Each practice will be fired by three cadets per Category. Points scored by the cadets in each practice will be added and average taken to arrive at the score of the Directorate in that competition. Award of medals will, however, be based on individual performance of cadets.



**RULES FOR SHOOTING COMPETITION FOR  
SENIOR/JUNIOR WING AND JUNIOR DIVISION (ANY WING)**

**Strength and Composition of Teams**

1. Each team will consist of six cadets each of SW, JW and JD of any Wing. Each cadet will fire only one practice. Selection of team including reserves will be done as per policy on random selection.

**Weapons**

2. Point 22 Mark III/Mark IV/Sporting/Deluxe Rifles will be used. Telescopic sights will not be used. Rifles will be properly zeroed before being brought to the camp. During journey rifles will be carried by PI Staff and not by Cadets. However, any Directorate team desirous to check zeroing of weapons of their cadets can do so before commencement of competition if such facilities are available.

**Ammunition**

3. Camp Commandant will provide ammunition for competition out of the ammunition brought by the Directorates. 500 rounds of .22 ammunition will be brought by each Directorate and deposited with the Camp Commandant before commencement of the TSC Girls for SW and JW competitions.

**Dress**

4. Normal working dress with hat/cap/pagri for boys and beret for girls.

**Practice**

5. Each practice will be fired by three cadets as under: -

**(a) Grouping.**

<u>Distance</u>	25 meters/ yards	
<u>Number of Rounds</u>	Five	
<u>Position</u>	Laying with rest	
<u>Target</u>	1' x 1' Grouping	
<u>Highest Points</u>	40	
<u>Time</u>	15 Minutes	
<u>Scoring</u>	2 cm and below	40 points
	2.1 to 3 cm	36 points
	3.1 to 4 cm	32 points
	4.1 to 5 cm	28 points
	5.1 to 6 cm	24 points
	6.1 to 7 cm	20 points
	7.1 to 8 cm	16 points
	8.1 to 9 cm	12 points
	9.1 to 10 cm	08 points
	10.1 to 11 cm	04 points
	More than 11 cm	00 points

**(b) Snap Shooting**

<u>Distance</u>	25 meters/ yards
<u>Number of Rounds</u>	Five
<u>Position</u>	Laying without rest
<u>Target</u>	Figure 11 miniature
<u>Highest Points</u>	50
<u>Time</u>	Five exposures of seven seconds duration each with an interval of not less than 10 seconds duration. Initially there will be a trial exposure. Where facilities for pop up targets are not available, timing should be controlled from the firing point by means of a whistle. The rifle will be loaded but not at aiming position. This will be raised only after the whistle is blown for each exposure.

6. **Note.** In case of a misfire or stoppage, additional exposure/ammunition will be permitted only for snap shooting. But in case a competitor fails to fire within the laid down timings no extra time/exposure will be provided.

**Award of Points to Directorates**

7. Each practice will be fired by three cadets per Directorate. Point scored by the cadets in each practice will be totalled and average taken to arrive at the score of the Directorate in that competition. Award of medals will, however, be on individual performance of cadets.

**Appendix G**

(Refers to Para 3 of General Rules)

**SPORTS SHOOTING (INTER DIRECTORATE,  
ALL INDIA GV MAVLANKAR, NATIONAL CHAMPIONSHIP)**

1. **Aim.** The aim of this is to encourage Sports Shooting amongst the cadets and reward the directorates, which produce good shooters.
2. **General.** Sports shooting will consist of Inter Directorate Shooting, participation in All India GV Mavlankar Shooting Championship (AIGVM) and National Shooting Championship Competitions (NSCC). Based on National Rifle Association of India (NRAI) shooting calendar, directorate(s) will be earmarked to conduct the competitions.
3. **Participation & Eligibility.** All matches will be held as per NRAI 2015 matchbook for uniformity and match numbers have been specified accordingly.
  - (a) Any NCC cadet can participate in IDSSC age less than 21 yrs on 31 Dec.
  - (b) AIGVMSC team will be composed of cadets who have participated in preceding IDSSC and MQS achieved in previous two yrs of National Zonal Shooting/ AIGVMSC.
  - (c) NSCC team will be composed of cadets who have participated in preceding AIGVMSC.

**IDSSC**

4. Each Directorate will field team as under:-

<b><u>Ser No</u></b>	<b><u>Matches</u></b>	<b><u>Position</u></b>		<b><u>Remarks</u></b>
		<b><u>Prone</u></b>	<b><u>3P</u></b>	
(a)	<b><u>.22 Peep Sight Matches</u></b>			Participants for prone and 3P matches may be common or separate as per selection by state Directorates. However peep and open sight participants will be different.
	(i) SD/JD Cadets	02	02	
	(ii) SW/JW Cadets	02	02	
(b)	<b><u>.22 Open Sight Matches</u></b>			
	(i) SD/JD Cadets	02	02	
	(ii) SW/JW Cadets	02	02	
	Total	08	08	

5. **.177 Air Rifle Shooting Trials.**
  - (a) State Directorate desirous of fielding cadets in .177 Air Rifle matches, may do so, subject to participation by a maximum of **04** cadets per Directorate.
  - (b) Air Rifle Shooting matches will be conducted only as selection trials.
6. **Individual Matches for Championship.** All matches of .22 mm will be conducted as individual events.
  - (a) **.22 Peep Sight Junior Men Individual Event (Two SD/JD Cadets)**

(i) **Match No-1**

- (aa) Position- Prone
- (ab) NRAI Match No.- A-4
- (ac) Ammunition- .22 mm K F- 5+60=65
- (ad) Time - 15 minutes for preparation and sighters and 1 hr for match.

(ii) **Match No.2**

- (aa) Position- Three Position (3P)
- (ab) NRAI Match No.-**A-13**
- (ac) Ammunition- .22 mm K F- 5+20, 5+20, 5+20=75
- (ad) Time - 15 minutes for preparation and sighters and 2 hr for match.

(b) **.22 Peep Sight Junior Women Individual Event (Two SW/JW Cadets)**(i) **Match No.3**

- (aa) Position- Prone
- (ab) NRAI Match No.- A-6
- (ac) Ammunition- .22 mm K F- 5+60=65
- (ad) Time - 15 minutes for preparation and sighters and 1 hr for match.

(ii) **Match No.4**

- (aa) Position- Three Position (3P)
- (ab) NRAI Match No.-**A-15**
- (ac) Ammunition- .22 mm K F- 5+20, 5+20, 5+20=75
- (ad) Time - 15 minutes for preparation and sighters and 2 hr for match.

(c) **.22 Open Sight Junior Men Individual Event (Two SD/JD Cadets)**(i) **Match No.5**

- (aa) Position- Prone
- (ab) NRAI Match No.-**A-20**
- (ac) Ammunition- .22 mm K F- 5+60=65
- (ad) Time - 15 minutes for preparation and sighters and 1 hr for match.

(ii) **Match No.6**

- (aa) Position- Three Position (3P)
- (ab) NRAI Match No.-**A-26**
- (ac) Ammunition- .22 mm K F- 5+20, 5+20, 5+20=75
- (ad) Time - 15 minutes for preparation and sighters and 2 hr for match.

(d) **.22 Open Sight Junior Women Individual Event (Two SW/JW Cadets)**

(i) **Match No.7**

- (aa) Position- Prone
- (ab) NRAI Match No.-**A-19**
- (ac) Ammunition- .22 mm K F- 5+60=65
- (ad) Time - 15 minutes for preparation and sighters and 1 hr for match.

(ii) **Match No.8**

- (aa) Position- Three Poition (3P)
- (ab) NRAI Match No.-**A-28**
- (ac) Ammunition- .22 5+20, 5+20, 5+20=75
- (ad) Time - 15 minutes for preparation and sighters and 2 hr for match.

7. **.177 Air Rifle Shooting Trials** All .177 Air Rif events will be individual events.

(a) **.177 Peep Sight Air Rifle Individual Event**(i) **Match No.9**

- (aa) NRAI Match No **A-29**
- (ab) Ammunition- Air Pellets 5+40
- (ac) Time : 15 minutes for preparation and sighters and 50 minutes for match

(ii) **Match No.10**

- (aa) NRAI Match No **A-31**
- (ab) Ammunition- Air Pellets 5+40
- (ac) Time : 15 minutes for preparation and sighters and 50 minutes for match

8. **Ammunition / Air Pellets.** The participating State Directorates will cater for their own Ammunition (Foreign or Indian) as per the requirement. The respective Directorates as under will cater for ammunition:-

- (a) .22 mm K F - 2000 rds
- (b) Air Pellets - As required by participating Directorates.

9. **Target Paper.** All types of target paper (NRAI approved) will be provided by the conducting Directorate for the competition from authorized vendor.

10. **System for Awarding Points for IDSSC.** The Directorate accruing maximum points will be declared as the Champion Directorate. Teams not winning even a single medal will be awarded Position below teams which have won medals in the order of scores obtained during the competition. Every shooter obtaining an Minimum Qualifying Score (MQS) will earn 0.5 Bonus pts for his/her State Directorate for calculation of points towards overall Championship. The system for awarding points to decide the ranking of participating State Directorates is given below:-

<u>Type</u>	<u>Score Achieved</u>	<u>No of Cadets</u>	<u>Total Score</u>
	<b>A</b>	<b>B</b>	<b>A x B</b>
Gold Medal	5.0		
Silver Medal	3.0		
Bronze Medal	2.0		
Achieved Minimum Qualifying Score (MQS) (including medal winners)	0.5		
<b>Total</b>			

11. **Tie Breaker.** In case of a tie, the State Directorate winning maximum number of Gold Medals will be ranked higher. However, if the tie remains undecided, the number of Silver and then Bronze Medals will be taken into consideration for breaking the tie respectively.

12. **Trophies and Medals.** All medals and certificates will be procured by Conducting Directorate after the approval of design from HQ DG NCC & presented to cadets on the last day of IDSSC.

13. **Minimum Qualifying Score (MQS).** NRAI Match Book – 2015 MQS for qualifying score for participation in the AIGVMSC is as follows:-

<u>Events</u>	<u>Junior Men</u>	<u>Junior Women</u>
Peep Sight Prone	500	490
3 P Peep Sight Prone	450	450
Open Sight Prone	425	425
3 P Open Sight	390	390
Peep Sight Air Rifle	350	350
Air Pistol	330	320

14. **Selection Criteria for Coaching and Selection Camp for DGNCC team.** The selection of DG NCC Shooting team for AIGVMSC and NSCC will be based on the cadets achieving highest score.

### **AIGVMSC**

15. The system for awarding points to decide the ranking of participating State Directorates for AIGVMSC is given below:-

<u>Type</u>	<u>Score Achieved</u>	<u>No of Cadets</u>	<u>Total Score</u>
	<b>A</b>	<b>B</b>	<b>A x B</b>
Gold Medal	5.0		
Silver Medal	3.0		
Bronze Medal	2.0		
Achieved Minimum Qualifying Score (MQS) (including medal winners)	0.5		
<b>Total</b>			

### **NSCC**

16. The system for awarding points to decide the ranking of participating State Directorates for NSCC is given below:-

<u>Type</u>	<u>Score Achieved</u>	<u>No of Cadets</u>	<u>Total Score</u>
	<b>A</b>	<b>B</b>	<b>A x B</b>
Gold Medal	5.0		
Silver Medal	3.0		
Bronze Medal	2.0		
<b>Total</b>			

### **RD Banner Points**

17. This competition will contribute 55 RD banner points as under:-

Inter Directorate Sports Shooting Competition (IDSSC)	40
AI GV Mavlankar Shooting Competition (AIGVMSC)	10
National Shooting Championship Competition	05
<b>Total</b>	<b>55</b>

18. Winning directorate will be allocated full RD banner points while other directorate will be allocated points as per formula below:

(a) **IDSSC.**

$\frac{\text{Points Scored by Directorate} \times 40}{\text{Points scored by winning directorate}}$

(b) **AIGVMSC.**

$\frac{\text{Points Scored by Directorate} \times 10}{\text{Points scored by winning directorate}}$

(a) **NSCC.**

$\frac{\text{Points Scored by Directorate} \times 05}{\text{Points scored by winning directorate}}$

**INTER DIRECTORATE LINE AREA AND FLAG AREA COMPETITION RULES**

**General**

1. Inter-Directorate Line Area and Flag Area Competition will be a Contingent Events carrying 390 points (to be scaled down to 80 for RD Banner). The breakdown will be as under: -

<b><u>Ser No</u></b>	<b><u>Event</u></b>	<b><u>Total Points</u></b>	<b><u>RD Banner Points</u></b>	<b><u>Annexure</u></b>
(a)	Line Area Competition	220	30	H1
(b)	Flag Area Competition	170	50	H2

2. Inter-Directorate position for award of points for RD Banner will be worked out after adding scores in the above two competitions. Winner Directorate of the Line and Flag Area Competition will be presented separate Trophies.

**Assessments**

3. A team of judges appointed by the OIC Competitions will inspect and assess Line Area & Flag Area briefing. Assessment will be carried out as under: -

(a) Line Area - Two assessments for each Directorate.

(b) Flag Area - Two assessments throughout the RD Camp.

4. Assessment will be done between 0900-1200 hrs. The dates of assessment will be reflected in the daily Camp Programme/forecast of important events well in advance. Inspection of the Line Area by the Judges will be conducted in a random sequence and not in a set pattern/sequence.

5. The above competitions will be held during the RD Camp.

**Allotment of Areas**

6. Allotment of 'Flag Areas' will be as per alphabetical order of state directorates from right to left to be indicated by OIC Competition on ground.

**Time Schedule**

7. Preparation work on Line and Flag Area will be permitted only during the following timings: -

(a) Preparation to start wef 02 January first light.

(b) Upto 05 January. At all times, except between 2100-0600 hrs.

(c) From 06 Jan onwards.

(i) 0600-0800 hrs

(ii) 1330-1700 hrs

(iii) 1900-2100 hrs



8. OIC Competitions will organize checks and ensure that no cadet works on Flag Area beyond the above permissible timings. However, in case of unforeseen interruptions like rain & dust storm, ADG (B) may permit Directorates to work beyond above time limits.

### **Special Effort for Visit of Prime Minister**

9. The Prime Minister's schedule on 27 January includes a visit to the Camp, and as such special efforts will be made to display the highest standard, notwithstanding commitments of 26 January and 27 January and impending termination of Camp on 28/29 January.

### **Disqualification**

10. In case it is established that any Contingent has deliberately spoiled Line and/or Flag Area of another Directorate, the defaulting Directorate will be liable to be disqualified.

### **Equipment**

11. Only chrome plated items will be displayed. No Directorate will bring separate set of items for display and daily use. Same items will be used for both these occasions.

### **Briefing at Flag Area**

12. "Each State Directorate will nominate three cadets (two SD/SW and one JD/JW) for briefing at Flag Area." The briefing will be in English only. The duration of briefing will be 02 Mins each.

13. Directorates will ensure that at least two of these cadets are available at all times for briefing of VIPs at Flag Area.

**Annexure H1**

## **LINE AREA COMPETITION**

### **General**

1. The Line Area Competition will cover the living area/barracks of Boy & Girl cadets, R&V barracks, school band barracks and contingent stores.

### **Allotment of Barracks (Boys)**

2. There are 11 barracks for Boys living accommodation as under: -

- (a) 8 barracks along the Raj Path and 01 barrack in row of Administrative Blocks.
- (b) 2 barracks (No 10 & No 11) for Band Contingent (boys), R & V Cadets and overflow of cadets from Rajpath Barracks
- (c) 8 partitioned pre-fabricated barracks for Stores of 17 Directorates

3. All barracks along the Raj Path have three floors and are divided in two halves. These are allotted as per alphabetical seniority. The Directorate securing 17<sup>th</sup> position in previous RDC Competitions will occupy the single barrack behind Rajpath. In case this directorate improves its position subsequently, it will swap barrack with the directorate now adjudged

last. The barracks would be furnished with required items as per indicated cadet strength. They would be maintained by the respective directorates throughout the year alongwith other stores. For this, HQ DGNCC will allot adequate funds to the Directorates. This will be coordinated by JD Logistic(Coord)/OC Camp. The allotted barracks will, however, be held on charge of th RDC Store NCOs of various directorates.

4. Each Directorate will accommodate cadets in one half of the barrack. Overflow of the cadets from the contingents, R & V Squadrons and Band will be accommodated by Logistic Directorate/OC Camp in the remainder two barracks as per Para 2 (b) above.

5. Line area competition will primarily be based on barracks along the Rajpath. However, all cadets other than R&V and Band will form part of the competition.

6. Stores will be accommodated in one half of the pre-fabricated barracks allotted to each Directorate.

### **Girls Barracks**

7. (a) Each barrack will accommodate 20 cadets.

(b) No draw of lots for girls' area accommodation will be carried out. Logistic Directorate will make allotment of barracks.

(c) A few girls' barracks may accommodate cadets of contingents from two or more Directorates.

### **Common Barracks**

8. Barracks housing cadets of more than one Directorate, occupied by R&V teams and school bands will also be prepared for Line Area inspection by all cadets staying in such barracks. Contingent Commanders of such cadets will jointly share the responsibility for cleanliness, maintenance, upkeep of the area, establishing of fire point and display of poles, chains, flowerpots, mirror, nominal roll, anti-snakebite kit etc. Contingent Commander of the directorate having the largest cadet strength will be responsible for coordinating the preparation of such barracks for Line Area Competition.

### **Fire Fighting Equipment**

9. Each Directorate will bring following stores for establishing Fire Points in boys/girls and store areas: -

- (a) Fire Extinguishers (preferably CO2 Type) - 8
- (b) Refills for Extinguishers (preferably CO2 Type) - 16
- (c) Bucket/Tins for Sand - 8 (4 each)
- (d) Shovels GS - 4
- (e) Axes Hand - 4
- (f) Axes Felling - 4
- (g) Axes Pick - 4
- (h) Fire Hooks and Beaters - 2 each

**Note.** Extravagant display of non-essential equipment in the fire point is not required. Fire extinguishers and other equipment will be checked for serviceability.

10. Each Directorate will establish three fire points at the following places: -

(a) Boys/Girls Area - A fire point will be established in front of each barrack. In front of barracks housing cadets of two Directorates, responsibility of establishing fire point will be that of Directorate having larger cadet strength in that barrack. Such Directorates, including Directorates having Band Cadets will bring extra fire fighting equipment over and above as laid down in Para 9 above.

(b) R&V barracks, School band barracks and Contingent Stores - Place to be indicated on ground by the Deputy Camp Commandant.

### **Criteria for Assessment**

11. The following will be the criteria for assessment of Line Area by the Board of Officers:-

<b><u>Ser No</u></b>	<b><u>Activity</u></b>	<b><u>Points</u></b>
(a)	General layout of the area and its cleanliness	80
(b)	Display of various orders both in English and Hindi (Camp Fire Fighting, Standing and Routine Orders)	20
(c)	Correct Layout, maintenance and serviceability of fire fighting equipment	20
(d)	Arrangement for throwing refuse (Dustbin and its use)	20
(e)	Cleanliness of barracks, use of curtains, dressing of cots and correct spacing between the cots and Layout of Kote and storeroom. Neat layout of lockers	20
(f)	Correct and uniform kit layout, authorised scale of items and deficiency if any. Sketch showing layout of items on/under the cot is enclosed as Annexure 1D	20
(g)	Use of Kit and equipment and its maintenance	20
(h)	Layout of Stores inside the stores barrack	20
	Total	220

### **Inspections/Assessments**

12. Assessment of Lines will be carried out separately for the boys' and girls' barracks, but on the same day. On the day of assessment total points scored by a Directorate in Boys & Girls Lines Area competition will be added and divided by two to arrive at the average marks scored by a Directorate. Lines will be inspected by the judges in a random sequence and no set pattern/sequence will be followed.

13. Surprise inspections after 'lights out' (2200 hrs) will be carried out by the officers detailed by OIC Competitions. Penalty points will be awarded to Contingents, incase cadets are found working or for any other violation of orders/instructions. Penalty points will be awarded to Directorates whose cadets are not found to be sleeping on the cots in the barrack.

**Layout of Barracks**

14. Layout of barracks is given as under: -

(a) **Layout of Girls' Area.**

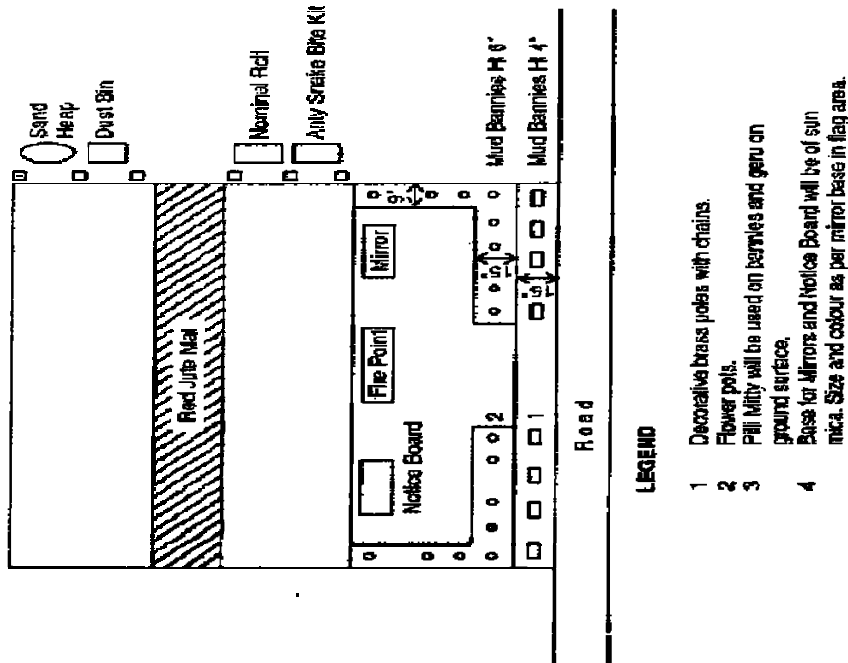

(b) **Layout of Boys' Area.**

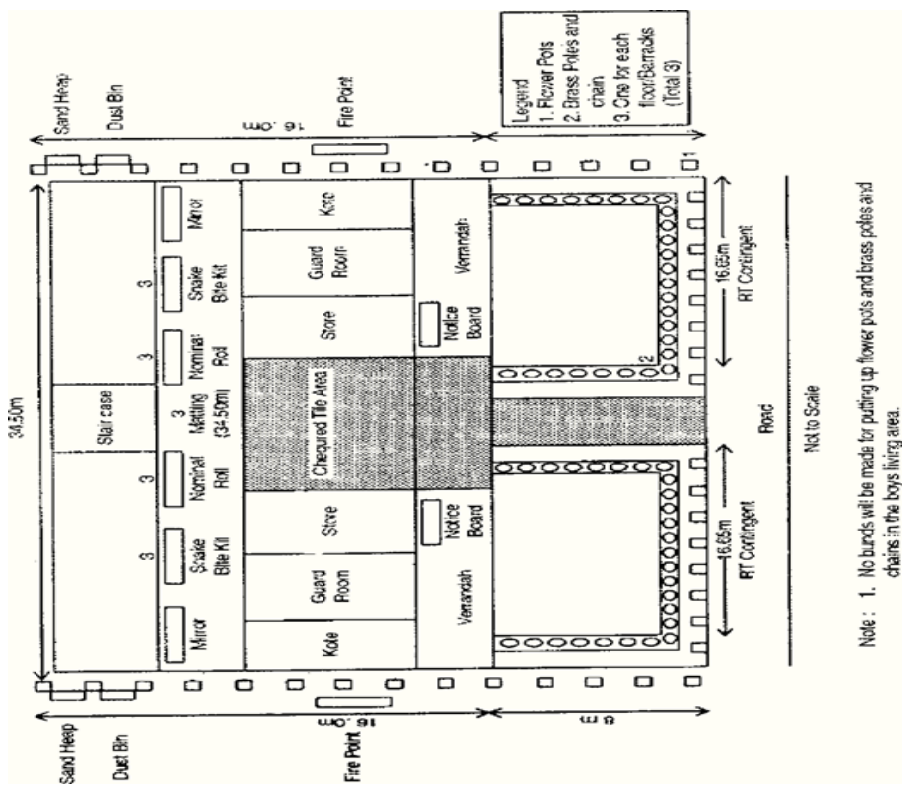

15. Fancy items will not be displayed in the Line Area. Emphasis should be laid in hygienic living conditions, cleanliness and aesthetic appearance. While display of items like Gong, Directorate Flag, Directorate Board, fire-fighting equipment etc is mandatory, no additional points will be awarded to ostentatious/extravagant display of non-essential items. However, since RDC is a national level event for which many dignitaries are invited to showcase NCC, limited display of items depicting cultural heritage of the respective States like flags, buntings, signboards, paintings, sculptures etc may be displayed. These should preferably consist of items fabricated by the cadets during the camp itself and should not be unduly expensive. No additional points will be awarded for such displays.

16. There will be no digging and no construction of mud and brick walls or models.

17. **Sketch Showing Top View Layout Of Items On/Under The Cot.**

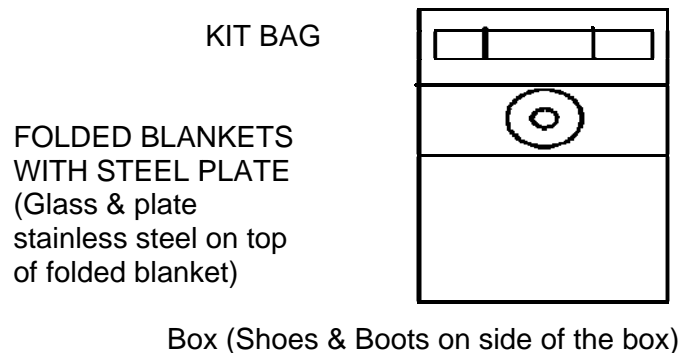

- (a) Stainless steel glass & plate will be displayed.
- (b) A bed card will be displayed on each kit. No photograph will be pasted on it.
- (c) Size of glass/plate/bed card will be standardized in each Directorate.
- (d) Notice Board & Snake bite kit on left hand side (while facing the main entry of the Barrack).
- (e) Mirror and dustbin on right hand side (while facing the main entry of the Barrack).
- (f) The layout will be checked on all the days throughout the camp except for the first two days when the camp is being set up and a day prior to the prize distribution/closing ceremony.

**Special Instructions.**

1. General cleanliness will be observed in the line area. All pits and depressions will be filled.
2. No duplicate sets of personal kit will be allowed for display purposes.
3. No Directorate will be allowed to dig the area in front of their barracks.
4. Standing Orders and Fire Orders, displayed in the Line Area will be both in Hindi and English.
5. Cadets will sleep in their separate beds. Two or more cadets sleeping in one bed will invite penalty points.

6. The contingent Store will present a tidy appearance and will be kept properly laid out during the day and night.

7. It will be ensured that the fire fighting equipment is adequate and in serviceable condition for extinguishing any fire in the Line Areas/Stores. The water and sand buckets will be filled  $\frac{3}{4}$ th and will be kept ready at all times. Not more than two fire extinguishers will be used at each fire point.

8. Bricks will not be used anywhere in the Lines.

9. The area of responsibility of contingents, for the purpose of general cleanliness and 'shipshape ness', will be indicated to the Contingent Commanders by the Camp Adjutant, on the ground. The broad parameters are given in succeeding Paras.

10. **Boys Area.**

(a) North East of Road. From the centre of the Road till the line of cookhouses.

(b) South East of Road. From the centre of the Road to PI Staff cookhouse and the line aligned towards East and West.

(c) Tarmac Road in front of the Contingent will be kept free of rubble and garbage drums kept on the roadside will not be filled with loose mud etc.

(d) Three feet area on either side of the Tarmac road will not be occupied and no structure/board will be erected in this space. In addition no perimeter poles, fire points, notice boards or any pre-fabricated items will be kept in this space. Contingents will, however, ensure to keep this space neat and tidy, as it improves the general get-up of the cadet lines.

(e) Similarly area up to the Cadet Cookhouses, Line and PI Staff Cookhouse Area will be kept clean by the Contingents. This area will be inspected and marked for RD Line Area Competition.

11. **Girls Area.**

(a) The above points on cleanliness are also applicable to Girl's area.

(b) Girl cadets will be put up in the Girls' Barracks. Each barrack will house 20 cadets. Some barracks will house cadets of 2 to 3 Directorates. In such barracks responsibility of layout of various boards, fire points (i.e. items which are common to a barrack) will be that of the Directorate having the larger cadet strength in that barrack.

(c) Nominal roll boards displayed outside will be suitably refabricated by putting up 2 to 3 boards outside each barrack.

(d) Contingents are permitted to use flower pots around the barracks. Number of flowerpots to be displayed is given at Enclosures 2 & 3 to Annexure 1 (indicated by small quadrangles).

(e) Girl cadets of Band will be housed together in separate barracks.

### FLAG AREA COMPETITION

#### Aim of Competition

1. Showcase the conceptual, artistic, imaginative and articulation skills of NCC Cadets working as a team and set standards of excellence that can be achieved to in pursuit of character development of cadets.

#### Specification

2. Each Directorate will be allotted a plinth area five meters long and three meters in width (5 m X 3m) inclusive of steel border bunds (all a around) with dimensions of 6" Width and 4" Ht, in Parade Ground as 'Flag Area'. All contingents will be responsible for maintenance of the gap to the right, while facing the opening of their flag area.

#### Display of Equipment in Flag Area

3. The following equipment will be displayed in the Flag Area :-

- (a) A flag mast with Directorate flag. (Each Directorate will bring one flag).
- (b) Decorative poles with chains.

#### Timing of Display

4. The 'Flag Area' will be kept covered with transparent polythene covers, to protect against rain and dust except for the following timings daily from 10 January onwards for the visitors :-

- (a) 0900-1300 hrs.
- (b) 1700-1900 hrs.
- (c) On Cultural Show days from 1700 hrs onwards till the VIP departs.
- (d) Any other time as specified for any special visit.

#### Marking

5. The allocation of points for Flag Area will be as follows :-

<u>S.No</u>	<u>Activity</u>	<u>Total Pts</u>	<u>RD Banner Pts</u>
(a)	Adherence to Instruction	15	20
(b)	Appearance and Presentation	30	
(c)	Maintenance of Flag Area	25	
(d)	Depiction of various aspects of the theme	30	
(e)	Briefing (Two SD/SW and One JD/JW Cdts in English)		30
	(i) Adherence to time (03 x Cdts for two minutes each)	15	
	(ii) Confidence and delivery	25	
	(iii) Interpretation of theme and salient	30	

	aspects covered		
	<b>Total</b>		<b>70</b>

**Note.** A half mark penalty will be awarded to a Directorate exceeding the briefing by upto 30 seconds and multiple thereof (for each 30 seconds) out of total 15 points earmarked for adherence to time as given out at Para 6(e)(i) above. A standard size uniform pointer for briefing would be procured centrally by RDC Adjutant for all Dtes.

6. **State Collage.** A map of the State/States depicting collage showing the State achievements and development projects, Tourism & Handicrafts, Important personalities, Culture, Heritage, Art & Music, Historical Significance and Education and Youth affairs etc alongwith NCC related activities will be displayed at the head of the Flag Area. The size of this collage will be 11.8' (width) and 9½' (height). It will be prepared on a white flex cloth and displayed with the help of a metal frame provided at the site by DGNCC. Sketch is given below :-

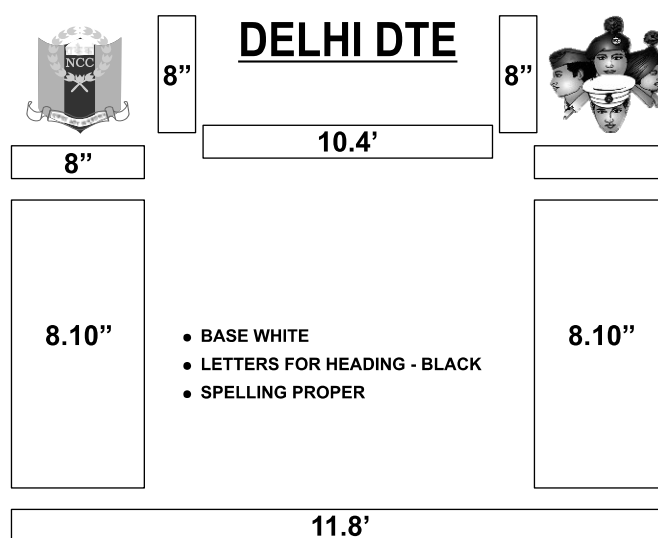

7. **Flag Area theme.** The theme for Flag Area is to be State/States specific covering following :-

- (a) State achievements and development projects.
- (b) Tourism & Handicrafts.
- (c) Important Personalities.
- (d) Culture, Heritage, Art & Music.
- (e) Historical Significance.
- (f) Education and Youth affairs.
- (g) NCC related activities.

**Note :** Only marble chips will be used for decoration. Directorates will not display readymade models of Humans/Animals/Historical-Cultural structures etc.



8. **Dress.** The dress for cadets detailed for briefing would be as follows :-

- (a) NCC Uniform.
- (b) White gloves and spats.
- (c) RDC Badges.
- (d) NCC Scarf.

### **Provision of Flag Poles**

9. Camp Commandant will issue one flag pole with pulley and rope each, to all Directorates for the Flag Area. Directorates will bring one flag (123cm X 185 cm) of their Directorate for Flag Area competition.

### **Specification of Flag Area**

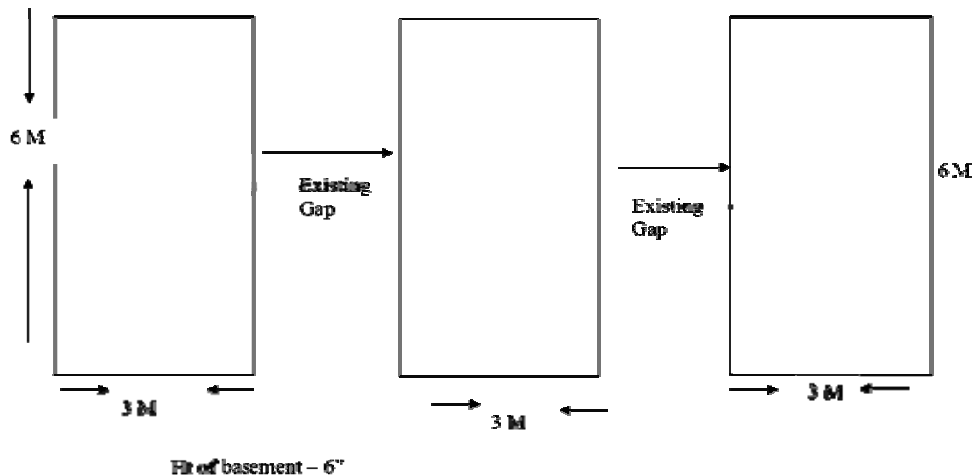

### **Specifications of Items Displayed in Flag Area**

1. The height of the flag pole when fixed on the ground will be 20 ft from the ground level.
2. The size of the NCC Directorate flag will be 6ft X 4 ft (185 cm X 123 cm) with the name of the Directorate embroidered thereon. All lettering will be bilingual.
3. Bund should be 4 inches (10 cms) high and 6 inches (15 cms) wide.
4. **Area Decor.** No construction or display material will be erected ahead of Front Bund line, towards the road.
  - (a) Poles and chain to be made of maintenance free material (nickel plated) with following dimensions :-
    - (i) Poles (20 No) with height of 47 cm (incl Globe) & Diameter of 6 cm.
    - (ii) Chain of 2 cm diameter.
    - (iii) Globe on the poles will be of 10 cm diameter.
    - (iv) No crest will be made on the poles.
    - (v) Chain during display should not be more that 2" above the wooden frame.
  - (b) Red matting / carpets to be spread between the respective Directorates Flag Area. Carpets will be procured centrally during RDC.
  - (c) Flower post with similar flower plants to be displayed between collage stand legs.

**INTER DIRECTORATE GUARD OF HONOUR AND  
RD PARADE PARTICIPATION COMPETITION RULES**

**General**

1. Inter- Directorate Guard of Honour and Republic Day Parade Participation Competition will be a Contingent Event and will carry 600 points towards the competition and will carry 81 points towards the RD Banner. This competition will be held in two parts as under:-

(a) **Part I.** Guard of Honour- 285 Points (38 Banner Points)

(b) **Part II.** RD Parade Participation – 315 Points (43 banner points)

2. **Marking.**

(a) The marks for cadets of each Directorate selected in Guard of Honour competition will be computed as under:

$$\frac{\text{NO OF CADETS SELECTED IN ALL WINGS X 38}}{12 \text{ (NO OF CADETS FIELDED)}}$$

(b) The marks for cadets of each Directorate selected in RD parade participation competition will be computed as under:

$$\frac{\text{NO OF CADETS SELECTED IN ALL WINGS x 43}}{20 \text{ (NO OF CADETS FIELDED)}}$$

(c) Both being individual competitions the marks scored for RD Banner points for each competition, will be shown separately.

**Venue**

3. The Competition will be held during RD Camp.

**Eligibility**

4. For Guard of Honour, each Directorate will field the following cadets:

(a) SD (Army) - 3

(b) SD (Navy) - 3

(c) SD (Air) - 3

(d) SW (Girls) – 3

5. SW cadets from Naval and Air Wings when selected for Guard of Honour will have to wear Army Wing uniforms. Hence, Directorates wishing to field girl cadets of Naval and Air Wings for selection of Guard of Honour, will get Army Wing uniforms (Terrycot) stitched for such cadets, on selection.

6. **Exemptions.** The following SD and SW cadets will not participate in any of the above two competitions: -

- (a) Cadets of R&V and Band.
- (b) Ship and Aero modelers cadets detailed by Dte.
- (c) Cadets participating in Cultural Programme & NIAP.
- (d) Cadets not selected for Guard of Honour can compete in RD Parade Participation Competition.

## **PART I- GUARD OF HONOUR**

### **Strength and Composition**

7. Each Directorate will submit a nominal roll of 12 cadets (3 each from SD Army, Navy, Air and SW) to Camp Commandant by 01 January, who in turn will hand over the nominal rolls to 'Presiding Officer'. J&K Directorate will field 6 SD (Army), 3 SD (Navy) and 3 SW cadets. This composition will be in force till Air Training is restored in J&K.

### **Selection**

8. **Number to be Selected.** 30 cadets each of SD (Army), SD (Naval), SD (Air) and SW will be selected including reserves. All cadets selected including reserves will attend rehearsals and parades. Final composition of Guard of Honour on a specified day will be decided by the Chief Training Officer (CTO), As far as possible all selected cadets will be given chance in turn to take part in Guard of Honour.

9. Selection will be based on the following considerations: -

- (a) Turn out and bearing
- (b) Squad drill
- (c) Arms drill
- (d) Steadiness

### **Weapons**

10. All cadets, including girls, participating in Guard of Honour will be equipped with 7.62 mm SLR (DP), Cadets will bring rifle slings as well, which will be covered with rexine.

### **Dress**

11. The dress will be as per Annexure J1.

### **Award of Penalty Points**

12. After the selection is over, if any selected cadet is found to be absent on rehearsals without sufficient cause, penalty points will be awarded. CTO will submit daily absentees list, (Directorate-wise), to DDG (Training) who, after ascertaining reasons from the Contingent Commander, will decide whether there is any justification for absence or not. Names of such

cadets will be submitted to OIC Competitions, as the concerned Directorate is liable to be awarded penalty points for this. All selected cadets will be in possession of Identity Cards. Cadets whose turnout on any ceremonial Guard of Honour is not found up to the mark can be awarded penalty points as mentioned above.

### **Rehearsals / Parades**

13. Officer/PI Staff of each contingent will bring their selected cadets for Guard of Honour selection and for subsequent practices to the training area as per Camp Programme, after inspecting their turnout and rectifying their faults. He will also hand over to CTO/Training Officer the Parade State indicating the following: -

- (a) No of cadets selected for Guard of Honour.
- (b) No on Parade.
- (c) Absentees with reasons.

### **Notes.**

14. **Guard of Honour Selection.** The following procedure will be adopted:

- (a) There will be a conference in the Conference Room at 1500 hrs on D minus 2 day. All Judges and Contingent Commanders will attend. Contingent Commanders will bring nominal roll and parade state of the cadets taking part in Guard of Honour and RD Parade Participation Competition.
- (b) Nominal roll will be tallied with Secretary RD Cell by Dir MS.
- (c) Guard of Honour cadets (Army, Navy, Air) and SW will fall-in at 0730 hrs, or time given by Presiding Officer, on D day, directoratewise for checking. Cadets will have identity cards with them. Contingent Commanders will be present.
- (d) After checking, all contingents will be mixed up by OTA/IMA trained Drill NCOs for KADWAR sizing and handed over to Presiding Officer at 0800 hrs for selection of the cadets.
- (e) Selection will be done as per briefing/instructions of the OIC Competition.
- (f) List of the selected cadets will be prepared in triplicate, Directorate wise. One copy will be handed over to Secretary RD Cell, one copy to Camp Commandant and third copy will be with OIC Competition.

15. **Manpower.** The following staff is required:-

- (a) OTA/IMA trained Drill JCOs/NCOs - Four
- (b) PI Staff JCOs - Two
- (c) PI Staff NCOs - Six
- (d) GCI - Two

16. **Stores.** JCO I/C along with PI Staff will be responsible to procure stores and lay out the furniture, as per requirement and instructions of the Presiding Officer.

## **PART II: REPUBLIC DAY PARADE PARTICIPATION RULES**

### **Strength and Composition**

17. For RD Parade participation, each Directorate will field the following cadets:

- (a) SD - 10
- (b) SW - 10

### **Selection**

18. 159 cadets each including reserves of SD and SW will be selected. In the SD 103 cadets from Army Wing and 28 cadets each from Naval and Air Wings, will be selected. SD Contingent will have eight rows of Army Wing and two each of Naval and Air Wings. In the SW contingent there will be at least one row each of Naval and Air Wing girl cadets (one row has 12 cadets).

19. Selection will be based on the following considerations: -

- (a) Turn out and Bearing.
- (b) Marching and Squad Drill.
- (c) Arms Drill.
- (d) Steadiness.

### **Weapons**

21. SD/SW (Army, Navy and Air ) participating in RD Parade Contingent competition will be equipped with 7.62 mm SLR with slings.

### **Award of Penalty points**

22. If any cadet is found absent or coming late on parade without sufficient cause, penalty points are liable to be awarded to the respective Directorate.

### **Rehearsals/Parade**

23. Officer/PI Staff of each contingent will bring their selected cadets of RD Parade for selection and subsequent practices at the training area, after inspecting their turn out and rectifying their faults and hand them over to CTO/Training Officer along with parade state indicating the following : -

- (a) No. of cadets selected for RD Parade.
- (b) No on Parade.
- (c) Absentees with reasons.

### **Recommended Selection Procedure**

24. In order to save time, avoid cluttering up and speedy selection, competition will be held in three phases as under: -

- (a) **Phase I.** SD (Army) Cadets
- (b) **Phase II.**SD (Navy and Air) Cadets
- (c) **Phase III.** SW Girls Cadets

25. **Phase I: SD (Army) (D Day).**The following procedure will be adopted:

- (a) SD (Army) will fall-in on D Day Directorate-wise in alphabetic sequence with nominal roll and Identity Cards. Cadets will be in possession of Identity Cards and Contingent Commanders will be present at the time of checking.
- (b) After checking by Judges, Drill Instructors (JCO/NCOs) will get KADWAR sizing done, thereby mixing all cadets. The Presiding Officer will position them in details and the entire Board of Officers will collectively select cadets from each detail. A final selection may be carried out from the preliminary selected lot of cadets, if required to attain the desired number of cadets.
- (c) Three copies of nominal roll of the selected cadets will be made directorate-wise.

26. **Phase II: SD (Naval & Air) (D plus 1).**The following procedure will be adopted: -

- (a) Naval and Air cadets will fall-in Directorate wise, in alphabetic sequence with nominal roll and Identity Cards.
- (b) The cadets will be checked simultaneously by Judges and KADWAR sizing done by Drill Instructors (JCO/NCOs). SD Cadets (Navy and Air) will fall in separately at a distance of 100 yards apart.
- (c) Procedure outlined for SD Army cadets will be followed.
- (d) Three copies of nominal roll will be prepared separately for Navy and Air Cadets.

27. **Phase III: SW (Girls) (D plus 1/D plus 2).**The following procedure will be adopted: -

- (a) SW Girls will fall in Directorate wise, in alphabetic sequence, at one place, with nominal roll and Identity Cards.
- (b) The cadets will be checked simultaneously by Judges and KADWAR sizing will be done by Drill Instructors (JCO/NCOs).
- (c) Procedure outlined for SD Army cadets will be followed.
- (d) Three copies of nominal roll, Directorate wise, will be prepared.

28. **Manpower.** The following staff is required:-

- (a) OTA/IMA trained Drill JCOs/NCOs - Four
- (b) PI Staff JCOs - Two
- (c) PI Staff NCOs - Six
- (d) GCI - Two

29. **Stores.** JCO I/C along with PI Staff will be responsible to procure stores and lay out the furniture, as per requirement and instructions of the Presiding Officer.

**Dress to Be Worn by Cadets**

<b><u>Army Senior Division</u></b>	<b><u>Army Junior Division</u></b>
Beret (single piece)/ Pagri Dark Green with NCC Cap/Pagri badge and Red Hackle	Beret (single piece)/ Pagri Dark Green with NCC Cap/Pagri badge and Red Pom Pom
Shirt Khaki Terrycot (full sleeves) with jersey	Shirt Khaki Terrycot (full sleeves) with jersey
Trousers Khaki terrycot	Trousers Khaki terrycot
Vest Woollen	Vest Woollen
Socks Black	Socks Black
Boots Black Leather DMS	Shoes Black Leather
Belt leather black with NCC buckles	Belt leather black with NCC buckles
Accoutrements as per Dress Regulations	Accoutrements as per Dress Regulations
<b><u>Navy Senior Division</u></b>	<b><u>Navy Junior Division</u></b>
Beret (single piece)/ Pagri White with NCC Cap/Pagri badge and Red Hackle	Beret (single piece)/ Pagri White with NCC Cap/Pagri badge and Red Pom Pom
Shirt white with Jersey	Shirt white with Jersey
Trousers White Terrycot	Trousers White Terrycot
Vest Woollen	Vest Woollen
Socks Black	Socks Black
Boots Black Leather DMS	Shoes Black Leather
Belt leather white with NCC Buckle	Belt leather white with NCC Buckle
Sling Rifle Nylon White	-
Accoutrements as per Dress regulations	Accoutrements as per Dress regulations
<b><u>Air Wing Senior Division</u></b>	<b><u>Air Wing Junior Division</u></b>
Beret (single piece)/ Pagri Sky Blue with NCC Cap/Pagri badge and Red Hackle	Beret (single piece)/ Pagri Sky Blue with NCC Cap/Pagri badge and Red Pom Pom
Sling Rifle web black	-
Trousers LBG terrycot	Trousers LBG terrycot
Vest woollen	Vest woolen
Socks woolen black	Socks woolen black
Boots black leather DMS	Shoes black leather
Belt Leather Black with NCC buckles	
Accoutrements as per Dress regulations	Accoutrements as per Dress regulations
Shirt LBG (Light Blue Grey) Terrycot full sleeves with Jersey sleeves with jersey	Shirt LBG terry cot full Jersey sleeves with jersey
<b><u>Girls Senior Wing</u></b>	<b><u>Girls Junior Wing Junior</u></b>
Beret (single piece)/ NCC Cap/Pagri badge and Red Hackle	Beret (single piece)/ NCC Cap/Pagri badge and Red Pom Pom
Shirt Khaki terrycot full sleeves tucked in with jersey	Shirt Khaki terrycot full sleeves tucked in with jersey

Trousers Khaki terrycot	Trousers Khaki terrycot
Vest Woolen	Vest Woolen
Socks Black	Socks Black
Boots Black Leather DMS	Shoes Black Leather
Black Belt Leather with NCC buckles	Black Belt Leather with NCC buckles
Accoutrements as per Regulations	Accoutrements as per Regulations

### **Notes for All Wings**

1. Right and left markers will wear Red Sash.
2. Army wing girls will wear 'tucked-in' shirt with black belt leather with NCC buckles.
3. The dress for Naval Wing and Air Wing girl cadets will be the same as laid down for Boys.
4. When wearing shirt, girls cadets will wear black leather belt with NCC buckles. Accoutrements like badges of rank, authorised camp badges(NSC, VSC, TSC, RDC, adventure activities) badges will be worn.
5. Cadet contingent commanders will not carry any arms/cane.
6. All cadets will wear service specific bilingual name-plates (black with white lettering).
7. Metal Brovel (Powered Flying), Metal Brovel (Gliding), will be worn above the left breast pocket of the shirt, by the eligible cadets only.
8. All the cadets will wear seven-sided RD Camp badge on right breast pocket below the button.
9. Points will be deducted if cadets are found not wearing appropriate or wearing unauthorised badges/stripes of rank, NCC certificate proficiency badges, shoulder titles and such like accoutrements as per NCC Dress Regulations.
- 10. All Cadets will wear Badges of Rank of Zari (for authorised cadets only), Shoulder title in zari thread, NCC Scarf with vertical woven zari, NCC Kamarband with woven zari**



### **NATIONAL INTEGRATION AWARENESS COMPETITION**

#### **General**

1. National Integration Awareness (NIA) Competition has been instituted in order to fulfil the Aims of NCC.

#### **Conduct**

2. The Competition will be conducted during the RDC, in NCC Auditorium.

3. Each Directorate will give a National Integration Awareness Presentation (NIAP) covering various aspects of their respective State/UT to include cultural heritage, history, geography, social customs, development, and economy etc. This could be in the form of lectures, one act plays, visuals or combination of all. The other details are as under: -

(a) **Strength.** Maximum of 20 cadets will participate. These cadets will be common from 35 cadets nominated by directorates for Cultural Programme Competition. There is no restriction on participation of SD/SW/JD/JW Cadets, Directorates may field more number of JD/ JW Cadets but maximum number will remain as 20 only. If lesser No of cadets are selected for presentation, the No must include a mix of cadets from SD, SW, JD and JW.

(b) **Duration.** Duration of the presentation will be 30 minutes.

4. The following aspects will be noted during the competition: -

(a) Participants for competitions including those who provide background music will be cadets only. Identity cards will be checked before the competition begins.

(b) The presentation and decoration/display of items on the stage/permitted area alone will count towards the competition. Display of items will be restricted to areas along and on either side of the stage. Display of items outside the stage or the Auditorium will not be permitted. Heavy, expensive/extravagant and cumbersome items for stage décor should be avoided. Size of props will not exceed 8 feet in height and 12 feet in width.

(c) The entire team will be disqualified in case any unauthorised person participates, posing as a cadet.

(d) In case professional assistance is rendered after the cadets have assembled on the stage, a penalty of 5 marks will be imposed on the defaulting directorate's score.

(e) There will be an arrangement for light signals to control the timings. A green light will indicate the commencement of the time, an amber light will be used to warn the participants that only five minutes are left for the event to be over and a red light will be used to indicate to the participants that their allotted time is over. 2 marks will be deducted for each 60 seconds of extra time taken after the red light has been switched on.

(f) The entire team will be penalized by 5 marks per person in case the numbers of participants exceed the limit laid down.

(g) There will be a gap of 10 minutes between each NIA Presentation. It includes 03 minutes to clear the Stage and 07 minutes for preparation (set up) by presenting Dte. The Dte will be liable to imposition of penalty in case of undue delay beyond the stipulated time. Such penalty will be imposed at the discretion of the Chief Judge (Presiding Officer of the Bd of Officer).

### **Submission of Nominal Roll & Synopsis**

5. Directorates will submit the nominal roll of their teams (less Guard of Honour, Rajpath, PM Rally, R&V Squadron & Band cadets) and synopsis of their presentation to the OIC Competitions and Judges 24 hours in advance of the Competition. Any changes in the composition of teams due to unforeseen circumstances will be considered only on the written request of the Contingent Commander, giving reasons for such a change. Till it is approved by the OIC Competitions, no change will be accepted.

### **Administrative Arrangements**

6. Administrative Arrangements for the competition, on all days, will be made by the Camp Commandant.

### **Judges**

7. The competitions will be judged by a Board of Officers or recognized/ eminent personalities, if available.

### **Declaration of the Results**

8. Results of competitions will be finalized and signed by the Board of Officers/Judges. These will be announced after approval of the DG.

### **Stage Decoration**

9. Contingents should bring with them all the equipment/accoutrements required for the Part I of the competition. 'Diyas' or other flammable props are not allowed.

### **Marking**

10. A total of 120 marks will be awarded for the competition which will be reduced to 60 marks towards the RD Banner. Sub allotment of marks is as given below :-

- (a) Display of Publicity/Motivational Material - 15
- (b) Synopsis - 15
- (c) Speaker's delivery & diction - 25
- (d) Innovations / variety of Presentation - 25
- (e) Facts and figures (Authenticity and Selection of material) - 25
- (f) Sequence of Presentation - 15

### **Prizes**

12. Individual prizes will not be given to cadets. However, prizes will be awarded to Directorates acquiring 1st, 2nd and 3rd positions.

**INTER DIRECTORATE MARCH PAST COMPETITION DURING PM'S RALLY**

**General**

1. Inter Directorate March Past Competition during PM's Rally will be a Contingent Event and will carry 144 points towards the RD Banner. This Competition will consist of Turnout, Marching, Dressing, Word of command and Drill Movements. The Contingent will be without Arms.

2. The competition will be conducted in three parts as under :-

(a) **Part I.** This part will be conducted on 16 Jan every year during the rehearsals and **will carry 44 RD Banner Points.** The distribution of marks will be as under :-

(i) Turn Out	- 20
(ii) Marching	- 20
(iii) Dressing	- 20
(iv) Word of Command	- 20
(v) Drill Movements	- 20
<b>Total</b>	<b>- 100</b>

(b) **Part II.** This part will be conducted on the day of DG's Full Dress Rehearsal and **will carry 50 RD Banner Points.** The distribution of marks will be as under :-

(i) Turn Out	- 20
(ii) Marching	- 20
(iii) Dressing	- 20
(iv) Word of Command	- 20
(v) Drill Movements	- 20
<b>Total</b>	<b>- 100</b>

(c) **Part III.** This part will be conducted on the day of PM's Rally on 28 Jan and **will carry 50 RD Banner Points which will be counted towards the next year PM's Banner competition.** The contingents will be judged based on their Turnout, Marching and Dressing. The distribution of Marks will be as under :-

(i) Turn Out	- 30
(ii) Marching	- 40
(iii) Dressing	- 30
<b>Total</b>	<b>- 100</b>

**Composition**

3. All directorates will pre- nominate 30 Cadets for PM Rally and utilize the left over from GOH & Rajpath to boost strength to 50 per directorate. The final composition of the contingent will be contingent will consist of the following: -

(a) SD (Army) - 28

(b) SD (Navy) - 06

(c) SD (Air) - 06

(d) SW (All Wings) - 08

Total - 48+1\*+1 @ = 50 (\*Placard bearer @Commander)

**Note:** The last two cadets in the file of Air & Naval Wing will be of Army Wing.

4. J&K Directorate will field 06 additional cadets from SD (Army) till the Air Wing training activities are revived in the State. Their cadet strength will be 50 from SD (Army). Directorates may field JD/JW Cadets for the above competition.

### **Exemption**

5. The following Cadets will not participate in this Competition:

(a) Cadets of R&V units.

(b) Ship & Aero modelers

(c) Cadets for Para Sailing & Slithering

(d) Cadets selected for Guard of Honour, RD Parade Contingent on Rajpath, NAIP & Cultural Programme.

### **Dress**

6. The Dress will be same as applicable for RD Parade Participating contingents (Spads and Gloves will be worn). **Appendix J refers.**

### **Nominal Roll**

7. Contingent Commander will submit the nominal roll of the Contingent to the Presiding Officer one hour in advance separately for each wing.

### **Marking of Competition Ground & Administrative Arrangements**

8. OIC Competition will select and decide the layout of the ground. Presiding Officer will brief the Training Team JCO, who will carry out the detailed marking of the ground. One Assistant Competition Officer will be nominated for marshalling the Contingent as per timings allocated to them. The administrative arrangements for the event will be made under the supervision of Camp Assistant Adjutant.

### **Board of Officers/ Judges**

9. The Board of Officers will be detailed by the DDG (MS) and will be constituted of officers from HQ DG NCC, OTA Kamptee and OTA Gwalior.

### **Sequence of Action**

10. A Directorate Contingent will have a placard bearer, (indicating name of the Directorate and will be supplied centrally under arrangements of Camp Commandant), Contingent Commander and Cadets as per given strength. Squad will form up 6 abreast with three files of cadets from SD (Army), one file each of SD (Navy), SD (Air) & SW. Cadets will be without arms. The assessment will commence with Cadet Contingent

Commander stepping out to take permission from the Chief Judge. Sequence of events, drill movement and words of command are given in the succeeding paragraphs and will commence on indication (Hand Signal) from Senior Judge (All will be at Vishram):-

(a) Cadet Contingent Commander will come to 'Savdhan' and bring his/her contingent to 'SAVDHAN'

(b) Cadet Parade Commander marches upto the Senior Judge, Salutes and seeks permission "..... Directorate PARADE SHURU KARNE KI AGYA CHAHTA/CHAHTEE HUN SRIMAN".

(c) He/She Salutes, turns about and takes up position marked for the Parade Commander facing the Squad.

(d) 'SAJ DAHINE SAJ' (Dressing by the right - First Cadet from the front line will act as Define Darshak turn right and take about 4 steps and 1 & 2 for halt) and about turn. Dressing will be with the right arm raised.

(e) Right Marker steps out and corrects dressing of each line.

(f) Thereafter Right Marker takes this position and Contingent Commander turns about facing the Chief Judge.

(g) Parade Commander marches forward, halt five spaces short of the Chief Judge and reports to the Chief Judge, "..... CONTINGENT APP KE NIRIKSHAN KE LIYE HAZIR HAI SRIMAN", salutes, turns about, halts at his/her marked place and turns-about facing the Presiding Officer (his/her back towards the Contingent). The board of Officers inspects the Parade Commander. After inspection, Parade Commander turns-about, facing the squad.

(h) Inspection of contingent by Judges is carried out one rank at a time. After the inspection, the Parade Commander will come to Savdhan', salute and commence the following procedure (drill movements and words of command): -

- (i) "...Directorate Contingent SAVDHAN"
- (ii) "Contingent VISHRAM"
- (iii) "Contingent SAVDHAN"
- (iv) "Contingent DAHINE CHALEGA - DAHINE MUR"
- (v) "Contingent AAGE BAREEEGA - BAEN MUR"
- (vi) "Contingent BAEN CHALEGA - BAEN MUR"
- (vii) "Contingent AAGE BARHEGA - DAHINE MUR"
- (viii) "Contingent PEECHE LOTEKA - PEECHE MUR"
- (ix) "Contingent AAGE BARHEGA - PEECHE MUR"
- (x) "Contingent VISHRAM"

(k) Contingent Commander will thereafter call the entire Contingent to Savdhan and seek permission for March Past.

(l) Thereafter the Contingent Commander gives the next word of command ".....CONTINGENT MADHYA SE TEJ CHAL". This will be done only once the Judges have inspected all contingents.

(m) On reaching the warning marker for Dahine Dekh, the contingent Commander starts giving word of Command, " .....Contingent DAHINE DEKH". This word of Command should terminate before the marker of DAHINE DEKH.

(n) On reaching the 'warning marker' for Sammne Dekh word of command "... Contingent SAMMNE DEKH" will be given. This should terminate before the marker for Sammne Dekh.

(o) The procedure mentioned above in sub para (m) and (n) will be repeated two more times on the given route for March Past.

(p) At the finishing point, which shall be indicated by two red flags, word of Command ".....Contingent THAM" will be given and on receiving signal from the Finish Point Officer, the word of Command "Contingent VISHRAM" will be given. Thereafter the Contingent Commander will march off the contingent.

**Appendix M**  
(Refers to Para 3 of General Rules)

**INTER DIRECTORATE CULTURAL COMPETITIONS**

1. **General.** Inter Directorate Cultural Competitions will carry 350 points towards the competition, to be scaled down to 70 points towards RD Banner. Events covered and allotment of marks will be as under:-

<u>Ser No</u>	<u>Item</u>	<u>No of participants</u>	<u>Time Allotted (minutes)</u>	<u>Marks</u>	<u>RD Banner Points</u>	<u>Annexure</u>
(a)	Group Song	10-20	06	100	70	M1
(b)	Group Dance	10-20	07	150		M2
(c)	Ballet/ Dance	04	06	100		M3
	<b>Total</b>			<b>350</b>		

**Note.** Total strength for all three items together, will not exceed 35 cadets. These cadets will also participate in NIAP Competition. These 35 cadets are not allowed to participate in Guard of Honour, Rajpath & PM Rally March Past Competition.

2. At the conclusion of the above competition, the total marks scored by each Directorate will be added up and an order of merit made. Points towards RD Banner out of 70 will be awarded.

3. However, individual prizes will be given to the cadets standing 1st, 2nd and 3rd in each event.

**Venue**

4. All the competitions will be conducted in NCC Auditorium located at the RD Campsite.

**Participation**

5. The following category of personnel will not participate in cultural competitions:

- (a) **Professionals.** Professional assistance of any kind is NOT permitted after the cadets have come on the stage.
- (b) Any person other than cadets of the RD Camp, as per the nominal roll submitted.
- (c) Officers, GCIs and PI Staff.
- (d) Cadets detailed for Band and R&V competitions.

6. The following points will be noted: -

- (a) Participants for competitions including those who provide background music will be cadets only. Identity Card will be checked before the competitions begin.
- (b) Music will be live except for Ballet where recorded music may be played.

(c) "For stage décor, heavy cumbersome articles will be avoided. Size of Props will not exceed 8 feet in height and 12 feet in width."

(d) The entire team will be disqualified if any unauthorised person forms part of the team.

(e) In case any professional assistance is rendered after the cadets have assembled on the stage, a penalty of 20 marks will be deducted from the Directorate score for this item.

(f) There will be an arrangement for light signals to control the timings. A green light will indicate the commencement of the time, an amber light will be used to warn the participants that only two minutes are left for the event to be over and a red light will be used to indicate to the participants that their allotted time is over. Maximum time for each event is laid down, and 01 mark will be deducted for each 03 seconds extra time taken after the Red light is switched on.

(g) The entire team will be penalised by 10 marks per person, in case the number of participants exceeds or are less than the limit laid down. Hence minimum and maximum strength of each event must be adhered to.

(h) Girl Cadets will wear only plastic bangles during competitions.

(j) Directorate will be liable to imposition of penalty in case of undue delay in presentation of their item. Such penalty will be imposed at the discretion of the Chief Judge (Presiding Officer of the Bd of Officer). However, 10 minutes to include 03 minutes to clear the Stage and 07 minutes to set up, will be allowed before consideration for penalty.

(k) Garments worn under the 'GHAGHRA' should preferably be of the same colour as that of the 'GHAGHRA'.

(l) Items will be selected judiciously for various Cultural Programmes and VIP visits.

### **Submission of Nominal Rolls and Synopsis**

7. Directorates will submit the nominal roll of their teams for each competition in triplicate to the OIC Competitions and Judges 72 hours in advance of the competition.

8. Synopsis of all events in Hind and English will also be handed over to Cultural Officer for submitting to the judges prior to the competitions. Synopsis is to be laminated on card of size 14 cm X 21 cm and shall not exceed 100 words.

9. Directorates will ensure that cadets are given requisite coaching and are deputed by name to read out the theme of the item being presented by their respective Directorates.

10. Any changes in the composition of teams due to unforeseen circumstances will be considered only on the written request of the Contingent Commander giving reasons for such a change. Till the Chief Judge approves it, no change will be accepted.

### **Board of Officers/Judges**

11. A Board of Officers nominated by HQDGNCC will judge the competitions. Addl DG (A) will approve the composition of the Board of Officers. Addl DG (A) will also be an observer to



oversee the conduct of the competitions and shall give, on the spot decisions in case of any dispute/protest. His decision will be final.

### **Declaration of the Results**

12. Results of each event will be finalized and signed by the Board of Officers/Judges. These will be announced after due approval of DGNCC.

### **Musical Instruments and Stage Decor**

13. Under mentioned instruments are allowed:-

- (a) Contingent will bring their own musical instruments, dress and other accoutrements required for their performance. In this regard the Directorate may contact their State Cultural representative in Delhi for necessary assistance.
- (b) Other arrangements necessary for conduct of the competitions on all days will be made by Officer In-charge Cultural who will be assisted by male and lady ANOs. In addition, two GCIs and two JCOs/NCOs will assist in communications on stage. Light & signal equipment will be arranged by OIC Signal.
- (c) 'Diyas' and similar flammable materials/props will not be used as there are fire hazards.

### **Administrative Arrangements**

14. Following arrangements will be done:-

- (a) All administrative arrangements for the competition on all days like provisioning of tables, chairs, glasses, water etc., will be made by the Camp Commandant. He will also be responsible for providing light refreshment to cadets outside the Auditorium.
- (b) Arrangement of Heaters for the Cadets outside the Auditorium.
- (c) Mess Secretary will be responsible for provision of light refreshment to officers & families outside the Auditorium.
- (d) Officers' Institute will cater for Light Refreshment for the judges during the conduct of competition.
- (e) Delhi Directorate and OIC Auditorium will be responsible for flower arrangements and stage decorations for all competitions.

### **Rules of Competitions**

#### **15. Group Dance**

- (a) Time - 5 Min + 2 Min (Max 07 Minutes)
- (b) Group - Minimum number of cadets – 10, Maximum number of cadets – 20 (Including musicians on stage or in the background)
- (c) Music and Instruments should be live.
- (d) Stage Decor - No professional or hired arrangements will be allowed.

(e) Points Allotted

<u>Presentation (40 points)</u>			<u>Composition, Dance &amp; Costume (55 points)</u>			<u>Music &amp; Instruments (55 points)</u>		<u>Total</u>
MC	Props	Presentation & Brochure	Synchronisation & Skills	Choreography & Innovations	Costumes	Quality of Music	Quality of Instrument Synchronisation	
5	10	25	25	20	10	35	20	<b>150</b>

16. Group Song

- (a) Time - 5 Min + 1Min (Max 06 Minutes)
- (b) Group - Minimum number of cadets 10, Maximum number of cadets 20 (including musicians on stage or in the background).
- (c) Dress - Appropriate
- (d) Language - Hindi/English/Regional
- (e) No dance of any type is permitted in this event.
- (f) Points Allotted

<u>Presentation (30 points)</u>		<u>Group Composition &amp; Dress (20 points)</u>			<u>Rendering &amp; Composition of Song (20 points)</u>	<u>Music &amp; Tune Quality (30 points)</u>	<u>Total</u>
MC	Overall Presentation & Brochure	Composition of Singers (Boys & Girls)	Instruments	Dress			
5	25	5	5	10	20	30	<b>100</b>

17. Ballet/Dance

- (a) Time - 5 Min + 1 Min (Max 06 Minutes)
- (b) Group - Minimum number of cadets – 04 (Excluding musicians on stage or in the background)
- (c) Music and Instruments can be live or recorded.
- (d) Stage Decor - No professional or hired arrangements will be allowed.

(e) Points Allotted

<u>Presentation</u> <u>(30 points)</u>		<u>Composition,</u> <u>Synchronisation &amp;</u> <u>Skills (40 points)</u>		<u>Theme</u>	<u>Music &amp;</u> <u>Background</u> <u>Score</u>	<u>Total</u>
MC	Props	Synchronisation & Skills	Choreography & Innovations			
5	25	20	20	15	15	<b>100</b>

**RULES FOR BEST CADET COMPETITION AND YEP SELECTION**

**General**

1. Best cadet and YEP competitions will be held during the RDC. These competitions are held to select 'best cadets', The selected cadets are awarded a 'baton' by the Prime Minister during the PM's Rally. The competition has the following components:

(a) **Best Cadet**. Only nine cadets per Dte will be fielded in the competition. Best Cadet (State) will not be held during RDC.

(b) **Best Cadet (State)**. This will be held at State Dte level only.

(c) **YEP Selection**. To select the cadets eligible for the YEP.

2. The Best Cadet competition will carry 100 points towards each of the nine categories. Total points contributing towards the RD Banner will be 50, which will be awarded separately for each category based on the merit list drawn, based on the results of the competition.

3. Besides the "interview and personality", the performance of the cadets in service subjects would be considered for selection for YEP.

4. "The Best Cadet and YEP selection competition will be run on similar lines though with varying bias as per the aim of the competition. Both the competitions will be run on a similar format as per the instruction given below."

**Aim**

5. The aim of the competitions is to select outstanding cadets of various State Directorates in a healthy competitive environment to provide them an opportunity to get a sense of achievement.

**Participation**

6. One cadet per directorate per category will participate in BC competition. The scores obtained by these cadets will be counted towards RD Banner. The competition will be conducted **for all nine categories** as under :-

(a) SD (Army)

(b) SD (Navy)

(c) SD (Air)

(d) SW (Army)

(e) SW (Navy)

(f) SW (Air)

(g) JD/JW (Army)

(h) JD /JW (Navy)

(j) JD/JW (Air)

7. A maximum of nine cadets per vacancy, for all the YEP vacancies (including reserve) allotted to the state may be nominated for the YEP.

### **Selection at Directorate Level**

8. Directorates will constitute a Board of officers to carry out screening/selection of participants in the Best Cadet and YEP Competitions as per criteria laid down by them, which will be in conformity with the rules framed by DG NCC. The DDsG of the respective Directorates shall preserve selection proceedings and results thereof for three years.

### **Submission of Nominal Roll and Bio-Data**

9. Nominal Rolls of the Best Cadet competition along with their Bio-data as per format promulgated are to be forwarded in triplicate to this HQ by 15 Dec. The photographs affixed on the Bio-data are to be duly attested by the DDG. These documents must be delivered to Dir MS /JD MS (A) by 15 December positively through a special courier who will be one of the PI Staff detailed on contingent duty RD Camp. Director/JD of the Directorate may sign the above documents only if DDG is not posted in that Directorate.

10. The bio-data of the YEP cadets will be submitted separately by the dtes to the Trg Dte.

11. Bio-data will be prepared on Bond Paper of A4 size and placed in separate file cover for each Cadet with Name, Number, Rank and Unit of the cadet written on the file cover. Best Cadet folders are to be sent to MS Directorate and YEP cadet folders to Training Directorate. For cadets recommended for both, two copies are to be sent to MS Directorate and one copy to Training Directorate.

12. Directorates will earn penalty points for submission of Bio-data later than 15 Dec. Each day of delay will earn a penalty of ½ point.

### **Eligibility**

13. Eligibility conditions will be as follows: -

(a) **JD/JW Cadets.**

- (i) Cadets of 8<sup>th</sup>, 9<sup>th</sup> & 10<sup>th</sup> classes only.
- (ii) Must have attended a minimum of 75% of parades conducted during the current year of NCC training.
- (iii) Cannot be from 1<sup>st</sup> year of NCC Training in JD/JW.
- (iv) Must have attended at least one camp.

(b) **SD/SW Cadets.**

- (i) Must have attended minimum one camp.
- (ii) Must have attended minimum of 75% of parades conducted during each year of his/her NCC training.
- (iii) Must be from 2<sup>nd</sup> or 3<sup>rd</sup> year of NCC Training in SD/SW.
- (iv) Naval/Air Wing cadet must have participated in watermanship/flying activities respectively.
- (v) Cadets in class XI in Sainik Schools having Senior Division will be permitted to compete in the Best Cadet Competition even though they may be from 1st year training of SD.

(vi) Nominees can be in the final year of NCC or graduation course. However, award of monthly scholarships listed in Para 14 (a) to 14 (f) below, will only be granted to cadets who are not in the final academic year of BA, B Com or B Sc, at the time of the competition.

(c) **YEP.** While the nominees for BC can be from the final year of NCC or graduation course, cadets sponsored for YEP/Naval Cruise will not be in the final year of NCC or graduation. This is because cadets selected for YEP during RDC actually proceed to a foreign country or Naval Cruise only in the next academic year. There is no provision for financing the expenditure of those cadets who cease to be part of NCC any more. For YEP, a cadet must pass in all subjects/ tests.

### **Awards & Incentives**

14. Winners of the Best Cadet competition will be awarded the following scholarships:-

(a) **SD (Army).** COAS Scholarship for one year is Rs 3600/- to be disbursed through the college in 12 monthly instalments of Rs 300/- each.

(b) **SW (Army).** COAS scholarship for one year is Rs 3600/- to be disbursed, through college, in 12 monthly instalments of Rs 300/- each.

(c) **SD/SW (Navy).** CNS scholarship for one year is Rs. 3000/- to be disbursed, through college in 12 monthly instalments of Rs. 250/- each.

(d) **SW (Air).** CAS Scholarship for one year is Rs 6000/- each to be disbursed through college in 12 monthly instalments of Rs 500/- each.

(e) **JD & JW (Air).** CAS Scholarship for one year is Rs 3000/- each to JD & JW to be disbursed through school in 12 monthly instalments of Rs 250/- each.

(f) **DGNCC Scholarship.** The DG NCC has instituted the following scholarships (to be awarded by Trg Directorate in cash/ cheque during RDC banner as per MoD letter No. 9827/H&A/NCC HQ/ MS (A)/51/D/GS-VI/2013 dated 18 Feb 2014) :-

(i) **SD (Army/Navy/Air) & SW (Army/Navy/Air)**

(aa) 1st position in each category - Rs 8,000/-

(ab) 2nd position in each category - Rs 6,000/-

(ac) 3rd position in each category - Rs 4,000/-

(ii) **JD/JW (Army/Navy/Air)**

(aa) 1st position in each category - Rs 6,000/-

(ab) 2nd position in each category - Rs 4,000/-

(ac) 3rd position in each category - Rs 2,000/-

15. Winners of the best cadet competition will also be presented the following awards:-

(a) Trophies & Batons by the Prime Minister at PM's Rally on 28 Jan.

(b) Medals/Prizes and Merit Certificate at one of the Prize Distribution ceremonies at the RDC. These will be distributed to the cadets securing first three positions in each category. Others will be issued certificates by Directorates for having represented the Directorate.

16. In addition to the above some Directorate/State Governments also give incentive/awards to the above awardees/prize winners.

### **Conduct of Competitions**

17. **General**. A Board of Officers/Judges composed of officers from HQ DG NCC, OTA Kamptee and OTA Gwalior will conduct tests for all the events of this competition. No test will be conducted by officers of any NCC Directorate/Group / Unit.

18. Interview Board will be constituted under the orders of DGNCC at every RD Camp. Results will be approved by the DGNCC and preserved by OIC competition, that is, DDG (MS) for 3 years.

19. Interview for Selection of BC and YEP. The interview for selection of BC will be two tiered as follows:-

(a) Interview by a Board of Officers consisting of the ADG (A) and Commandant OTA, Gwalior/ Kamptee or other DDGs from HQ DG NCC.

(b) Final interview by DG.

### **Tests**

20. **Written Test (General Knowledge)**. Candidates scoring less than 30 percent marks in the written test will be considered as "FAILED" unless relaxed by the DG based on the overall results.

(a) **Current Affairs**. (Covering period for twelve months commencing 01 Jan of previous year upto 02 Jan of RDC year). This may include the following:-

(i) <b><u>Own Country</u></b> . (25 points)	<b><u>Points Allotted</u></b>
(aa) Who's who	5
(ab) Political Situation	5
(ac) Economy	5
(ad) General Science and Technological Developments	5
(ae) Miscellaneous	5

(ii) Neighboring and Other Countries. (15 points)

(aa) Who's Who	5
(ab) Political situation	5
(ac) Miscellaneous	5

(b) **Sports**. (10 points)

(i) Indian	5
(ii) International	5

**Total 50**

(c) **Service Subjects (100 points)**

21. (a) <b><u>Drill.</u></b>	<b><u>Best Cadet</u></b>	<b><u>YEP</u></b>
• Turn Out	20	10
• Bearing	20	10
• Word of Command	20	10
• Control Over Squad	30	15
• Steadiness and Confidence	20	10
• Own Drill Movements	40	20
	<b>Total 150</b>	<b>75</b>

(b) **Firing - Best Cadet. (150 points)**

- Practice. Application
- Distance 25 M
- No.of rounds 15
- Position 5 shots each in Lying  
Unsupported, Standing and Kneeling  
Position
- Target NRAI 50 meter official target
- No of Shots per target 5 Shots
- Record Targets One for each position
- Scoring As per actual hit on target
- HPS 15 for each firer
- Weapons .22 Mark III/Mark IV/Sporting/ Deluxe  
Rifle
- **Timing, Misfires and Procedures.**

(aa) All practices will be timed. 100 seconds will be given for firing five rounds in lying and kneeling positions. 120 seconds will be given for the standing position practice. An additional 10 seconds per misfire will be given for a maximum of two misfires.

(ab) Therefore, at the firing point, the "Time Up" whistle/ signal will be given at the time for practice plus ten seconds plus ten seconds. Consequently, a lying/ kneeling position practice will be completed in a maximum of 120 seconds and the standing position practice will finish in 140 seconds.

(ac) Firing point judges will ensure that only misfires are fired in the extra time.

(ad) In case of more than five shots on a target, the poorest five will count. However, in case it is proved that the additional shots are due to the fault of another firer, the best shots will count.

22. **IQ & Personality Test. (300 points)**

- (a) Personal bearing, turnout disposition and mannerism
- (b) Communication skill, clarity of thought and expression.
- (c) Comprehension and intelligence
- (d) Response/Ability to react.



23. **DG's Interview. 100 points**

24. **Participation in other RD Events.** Maximum marks for this is 50. A Cadet can participate in a maximum of three of under mentioned events. 10 marks each will be allocated:-

- (a) Cultural Pgme (Ballet)
- (b) Cultural Pgme (Group Dance)
- (c) Cultural Pgme (Song)
- (d) NIAP
- (d) MC for Cultural Event
- (e) Flag Area Briefing
- (f) Motivation Hall Briefing
- (g) DG Award for outstanding performance – 10 Mks
- (h) Grouping of 3 cm or less (for YEP) and firing score of 125 or more (for Best Cadets) – 05 Mks  
Score of more than 70% in written test– 05 Mks
- (j) Guard of Honour /Rajpath – Participation in these events by cadet will not give them any point.

25. The scores for Best Cadet and YEP Competitions may be summarized as under:-

<u>Event</u> <u>YEP</u>	<u>Best Cadet</u>	
Written Test 100 = 150	50 (GK) + 100 = 150	50 (GK) +
Drill	150	75
Firing	150	-
Personality and Communication Skills	300	300
DG Interview	100	100
Participation in RDC Events	<u>50</u>	<u>50</u>
<b>Total</b>	<b>900</b>	<b>675</b>

Notes: (Minimum Performance Level)

(a) It is compulsory for Best Cadet competitors to participate in all events. In case of non-participation in any event the cadet will face a disqualification that will debar him from further participation in the competition.

(b) The actual marks secured in each subject/event of the test conducted for cadets competing in the Best Cadet Competition during RDC, will be included.

(c) For YEP participants written test and Firing test will be held first. Only those who clear both tests will be allowed to appear for subsequent tests.

26. OIC Competitions will compile the results including points awarded by the Interview Board. The total points acquired by each cadet will be divided by 10 to scale down the score out of maximum 100 points. The OIC Competitions will thereafter prepare the merit list of participants in their respective categories and of Inter Directorate positions separately.

27. Results of Best Cadet Competition will be submitted duly authenticated by the OIC Competition as under: -

(a) Interim Results. For obtaining security clearance for likely recipients of Best Cadet Awards at PM's Rally on 27 Jan, following particulars of three cadets leading in each of the six categories of Best Cadet Competition will be handed over to RD Cell & Dir (Coord), in triplicate, by 18 Jan: -

- (i) No, Rank and Name
- (ii) Wing/Division
- (iii) Unit and Directorate
- (iv) Date of Birth and Age
- (v) Fathers name, Occupation and Address

(b) Final Results. The final result will be handed over to RD Cell in triplicate by 1000 hrs on 22 Jan for arranging prize distribution, informing Directorates concerned and press release.

### **SPECIAL INSTRUCTIONS ON CONDUCT OF BEST CADET COMPETITION AND YEP SELECTION**

1. **Written Test.** All cadets appearing for Best Cadet and YEP Competition will appear for General Knowledge and Service Subjects Test. It will be held in the Auditorium where following preparations will be made under the instructions of Camp Commandant: -

(a) Seating arrangements.

(b) Tables will be placed for submission of answer sheets. These will be placed duly marked as under: -

- (i) Best Cadet SD (Army)
- (ii) Best Cadet SD (Navy)
- (iii) Best Cadet SD (Air)
- (iv) Best Cadet SW (Army)
- (v) Best Cadet SW (Navy)
- (vi) Best Cadet SW (Air)
- (vii) Best Cadet JW
- (viii) Best Cadet JD

(c) Chairs for invigilators

(d) Drinking water and toilet arrangements.

(e) All the competitors will bring their own clip boards and writing material.

(f) Arrangements for PA system in the Auditorium.

(g) The cadets will be marshaled near the Auditorium, 30 minutes before the start of the test.

- (h) Identity cards of the cadets competing will be checked before they are seated.
- (j) Cadets will be seated wing-wise. It will be ensured that cadets of any one Directorate do not sit in the same line.
- (k) Officers distributing the paper will have both English and Hindi version.
- (l) In case any cadet asks for any clarification in the question paper, invigilator on duty will make the cadet to stand up before giving out explanation or clarification.
- (m) Staff Required. Staff required for administrative arrangement is as under:-
- (i) JCO - 1
  - (ii) NCOs - 2
  - (iii) Lady NCC Officers /GCI/SMI - 2
  - (iv) Lascars – 4
- (n) **Stores Required**. The following stores will be required: -
- (i) Tables - 11
  - (ii) Drawing Sheets - As per requirement
  - (iii) Writing Material
  - (iv) Sign Board - 1 (Best Cadet & Youth Exchange Written Test)

2. **Drill**. All the Best Cadet competitors will appear for Drill Test. It will be held in one of the wings of Garrison Parade Ground. The following arrangements and method for conduct of drill test will be adopted: -

- (a) The drill will be without arms.
- (b) Staggered timing will be given to all wings (one hour for each wing).
- (c) Five squads of 12 cadets each will be arranged for squad drill and fault finding. These cadets should be other than the competitors for 'best cadet'.
- (d) Cadets will be marshalled 15 minutes earlier.
- (e) The competition will be held in two parts i.e., personal drill & words of command. The details are as follows: -
- (i) Personal drill, Turnout and Bearing.
    - (aa) All best cadet competitors of a Div/Wing shall be made to stand in one row or in twos and the Board of Officers shall give marks for their turnout and bearing.
    - (ab) Each cadet shall be made to do Drill individually. JCOs/NCOs will be briefed by the Board as to what words of command are to be given to the cadets.
  - (ii) Words of Command and Ability to Conduct Squad Drill. All cadets will be briefed on the procedure to be adopted and drill to be done. Each cadet shall be asked to conduct squad drill for a squad of 12 cadets.
  - (iii) Staff. The following staff will be made available by the Camp Commandant:-
    - (aa) JCO - 1
    - (ab) NCOs - 2

- (ac) UOI/SMI - 1
- (ad) Lascars - 2

- (iv) Stores. The following stores will also brought at the venue:-
  - (aa) Tables - 3
  - (ab) Chairs - 5
  - (ac) Stopwatch - 1
  - (ad) Clip Boards & Writing Materials (for Board of Officers) - 10
  - (ae) Blank Papers - 100
  - (af) Pencils - 10

3. **Firing Course.** Firing competition will be carried out, preferably in the training area of Rajputana Rifles Regimental Center (RRRC). Camp Adjutant/Assistant Adjutant/Officer detailed Camp Commandant will be required to carry out liaison with the Center and ensure that the ranges are available for these events as under:-

(a) Firing.

- (i) Short or Classification ranges at RRRC will be arranged well in time by personal liaison with their GSO 1 (Training). One copy of the 'range standing orders' will also be procured from RRRC.
- (ii) NRAI Target as required, including 50% reserve will be arranged on as required basis.
- (iii) All cadets will be asked to carry their personal weapons. SD cadets will also carry one DP/DPBF rifle for Obstacle Course.
- (iv) One Durrie/Ground Sheet, one Pull Through, one .22 Cleaning Rod and adequate targets and papers will be carried by each contingent.
- (v) Each contingent will bring adequate quantity of .22 ammunition to cater for both the Best Cadet as well as the YEP firers. The ammunition will be drawn by the JCO nominated for making the advance arrangements as per requirements two hours before the start of Firing Competitions. In this regard, the Adjutant should give written instructions to Kote JCO for issue of ammunition as well as for detailing an armourer.
- (vi) One x 3 Ton vehicle for carrying of stores, 3 x 3 Ton vehicle for conveyance of cadets and one x Gypsy for conveyance of officers will be detailed.
- (vii) The administrative vehicle will be sent to the firing range with staff and stores two hours before commencement of firing.
- (viii) All SD/SW/JW/JD cadets will be marshalled near the Range and their identity cards will be checked. Identity cards of SD cadets will also be checked prior to the Obstacle Course.
- (ix) Details of six cadets each will be made in a random sequence and necessary instructions passed on to the cadets by one of the Judges.
- (x) Warmer rounds will not be fired on the targets. Clear cut instructions on this account will be given by the Firing Point Officer to each detail, while issuing orders for firing.
- (xi) Point 22 Mark III/Mark IV/Deluxe/Sporting Rifle will be used. Telescopic sights will not be used.
- (xii) After firing by each Detail new target paper will be pasted for the next Detail. This process will continue (on each target) till firing is over.

(b) **Stores Required For Firing.**

- (i) Target frame 1'x1' - 16
- (ii) Target paper 1'x1' - 225
- (iii) Whistle. - 2

- (iv) Flag Red - 6
- (v) Red jacket - 4
- (vi) Durrie/Ground Sheet - 1 per contingent
- (vii) Pull through/.22 cleaning rod - 1 per contingent
- (viii) Table - 2
- (ix) Chairs - 4
- (x) Ammunition/.22 - 100 rounds per Contingent

(c) **Staff.**

- (i) JCO - 1
- (ii) NCOs - 2
- (iii) Lascars - 2
- (iv) Nursing Assistant - 1

(d) **Stores.**

- (i) Tables -3
- (ii) Chairs -4
- (iii) Kanats -4

**INTER DIRECTORATE DISCIPLINE COMPETITION**

**Aim**

1. The aim of this competition is to judge the directorates on the level of discipline maintained, to include the discipline of the State Directorate contingent during the RDC.

**Assessment**

2. This competition will be conducted in two parts as under :-

Ser No	Assessment	Total Points	RD Points	Banner	Annexure
(a)	Part 1 - Discipline & DV Cases	500	50		O1
(b)	Part 2 – Discipline during RDC	240	5		O2
		<b>740</b>	<b>85</b>		

**PART -I : DISCIPLINE AND DV CASES**

**Aim**

3. The aim of this part of the competition is to ensure that the State Directorates maintain acceptable standards of discipline and ensure timely completion of Courts of Inquiry into cases involving infringement of discipline.

**Assessment**

4. The assessment will be carried out as under :-

(a) **MT Accidents.** A penalty of ten (10) points will be imposed for each case of MT accident where the Court of Inquiry finds NCC personnel of the State Directorate to be at fault. This penalty will be imposed only on the State Directorate whose personnel are blamed for MT accident.

(b) **Accidental Death of NCC Cadet during Training Activity.** A penalty of twenty (20) points will be imposed for each case of death of an NCC cadet during training activity, where the Court of Inquiry finds NCC personnel of the State Directorate, conducting the Training activity, to be at fault.

(c) **DV Cases.** A graduated increase in penalty points will be imposed for non-completion of each Courts of Inquiry, Board of Officers and other discipline cases in time, as under :-

	<b><u>Time Frame</u></b>	<b><u>Penalty</u></b>
(i)	Completed in time	No penalty.
(ii)	First 10 days delay	Minus 5 points
(iii)	Second 10 days delay	Minus 10 points
(iv)	Third 15 days delay	Minus 15 points

(v)	Fourth 15 days delay	Minus 20 points
(vi)	Thereafter for every upto 30 days delay	Minus 50 points

(d) The penalty for delay in completing the inquiry/board for any particular case will not be for more than 365 days. The penalty will not be levied twice for same case.

(e) The merit list will be made as per the points obtained by the Dte after deduction of penalties from the total of 500 points.

(f) RD Banner points will be awarded as per the position i.e Dte coming first will get 50 RD Banner points, second 49 Points, third 48 points and so on.

### **Calculation of RD Banner Points**

5. The points will be calculated as under :-

<b><u>Ser No</u></b>	<b><u>Directorate</u></b>	<b><u>Number of Cases</u></b>	<b><u>Points</u></b>			<b><u>Position</u></b>
			<b><u>Total Awarded</u></b>	<b><u>Out of 500</u></b>	<b><u>RD Banner (50)</u></b>	
		<b>A</b>	<b>B</b>	<b>C</b>	<b>D</b>	
				<b>C - B</b>	<b>(C-B)/10</b>	

### **Duration**

6. This competition will cover the period 01 Dec 30 Nov. The State Directorates will forward quarterly returns as on 28/29 Feb, 31 May, 31 Aug, and 30 Nov to reach HQ DGNCC by 15th of the following month. A Final return for the complete period from 01 Dec to 30 Nov will also be forwarded so as to reach HQ DGNCC by 20 Dec. The reports will be forwarded to the MS Directorate with a copy to Training Directorate (RDC Cell).

### **Format of Returns**

7. The format of the returns will be as under :-

(a) **MT Accident: Return**

#### **MT ACCIDENT RETURN IN RESPECT OF DIRECTORATE FOR THE QR ENDING**

<b><u>Ser No</u></b>	<b><u>MT Accidents involving NCC Vehicles</u></b>	<b><u>Date of Accident</u></b>	<b><u>Accident reported vide</u></b>	<b><u>Court of Inquiry ordered vide</u></b>	<b><u>Blamed/ Not Blamed</u></b>	<b><u>Penalty Points</u></b>
	(Details of vehicles)		Letter Reference			

(b) **Accidental Death of NCC Cadet during Training Activity: Return**

#### **ACCIDENTAL DEATH OF NCC CADET DURING TRAINING ACTIVITY IN RESPECT OF DTE FOR THE QR ENDING**

Ser No	MT Accidents involving NCC Cadet	Date of Accident	Accident reported vide	Court of Inquiry ordered vide	Blamed/ Not Blamed	Penalty Points
	(Details of cadet)		Letter Reference			

(c) **DV Cases: Return****DV CASES RETURN IN RESPECT OF DTE FOR THE QR ENDING**

Ser No	DV Case	Court of Inquiry ordered vide	Date of Completion	Penalty Points
	(Details of vehicles)			

**Note**

- (a) All above returns must be timely and correct.
- (b) 10 penalty pts will be deducted for violation on either count.

**PART II - INTER DIRECTORATE DISCIPLINE COMPETITION DURING RDC****Aim**

8. The aim of the competition will be to ensure the discipline and well being of cadets during RDC.

**Duration**

9. The competition will be conducted from the time of arrival of contingents at Delhi till their departure. The period after 23 Jan will count towards the next RDC.

**Points**

10. The competition will be conducted out of 240 points. It will contribute 35 points toward the RD Banner.

**Conduct**

11. A board of officers will be constituted for conducting the competition. The board will not violations of discipline by cadets and award negative points as given below for each infringement:-

- (a) Major Violation - 5 Points per violation
- (b) Minor Violation - 1 Points per violation



**(c) Non nomination of cadets as per Special Instructions to ensure Pan India presence – 2 points per violation.**

12. Presiding Officers of various boards and officers in charge of various events will also inform the Presiding Officers of the Discipline Competition about any infringements by Directorates. Besides, the board will also conduct random checks and award penalty points, if any.

13. Points that will be checked for each violation are given below :-

**(a) Major Violation**

- (i) Use of foul language/fighting by cadets.
- (ii) Smoking.
- (iii) Consuming liquor.
- (iv) Found in out of Bounds area.
- (v) Movement of boys in Girl's area.
- (vi) Movement of girls in Boy's area.
- (vii) Arguing with superiors.
- (viii) Disobedience.
- (ix) Non adherence of Camp Discipline.
- (x) Feigning sickness.
- (xi) Stealing.
- (xii) Absent from camp.
- (xiii) Late on parade.
- (xiv) Any other major violation.

**(b) Minor Violation**

- (i) Dirty toilets.
- (ii) Throwing litter.
- (iii) Not making use of urinals and toilets.
- (iv) Line Area found dirty.
- (v) Dirtying of walls/staircases.
- (vi) Deficiency of bulbs or other accessories.
- (vii) Fire fighting equipment not functional.
- (viii) Improper hair cut.
- (ix) Not shaving.
- (x) Uniform not pressed.
- (xi) Boots not polished.
- (xii) Improperly turned out/shabbily turned out.
- (xiii) Consumption of food or water from un-authorised sources.
- (xiv) Any other misdemeanor.

**INTER DIRECTORATE CULTURAL COMPETITION DURING NIC - II, DELHI**

**General**

1. An Inter Directorate Cultural Competition will be conducted during NIC-II at Delhi. The competition will carry 100 points, to be scaled down to 15 RD Banner points.

**Events**

<u>Ser No</u>	<u>Item</u>	<u>Number of Participants</u>	<u>Time Alloted (mins)</u>	<u>Marks</u>	<u>RD Banner Points</u>	<u>Annexure</u>
(a)	Group Song	07 to 10	5	50	10	P1
(b)	Ballet/ Dance	04	6	50		
<b>Total</b>				<b>100</b>		

**Note.** Total strength for both items together, will not exceed 20 cadets.

2. At the conclusion of the above competition, the total marks scored by each Directorate will be added up and an order of merit made. Points towards RD Banner out of 10 will be awarded.

3. However, individual prizes will be given to the cadets standing 1st, 2nd and 3rd in each event.

4. **Venue.** All the competitions will be conducted in NCC Auditorium located at the RD Campsite.

5. **Participation.** The following category of personnel will not participate in cultural competitions:-

(a) **Professionals.** Professional assistance of any kind is NOT permitted after the cadets have come on the stage.

(b) Any person other than cadets of the NIC-II Camp, as per the nominal roll submitted.

(c) Officers, GCIs and PI Staff.

6. The following points will be noted : -

(a) Participants for competitions including those who provide background music will be cadets only. Identity Card will be checked before the competitions begin.

(b) Music will be live for Group Song. Recorded music may be used for Ballet /Dance.

(c) "For stage décor, heavy cumbersome articles will be avoided. **Size of Prop will not exceed 8 feet in height and 12 feet in width.**"

(d) The entire team will be disqualified if any unauthorised person forms part of the team.

(e) In case any professional assistance is rendered after the cadets have assembled on the stage, a penalty of 10 marks will be deducted from the Directorate score for this item.

(f) There will be an arrangement for light signals to control the timings. A green light will indicate the commencement of the time, an amber light will be used to warn the participants that only two minutes are left for the event to be over and a red light will be used to indicate to the participants that their allotted time is over. Maximum time for each event is laid down, and **05 marks will be deducted for each 30 seconds of extra time taken after the Red light is switched on.**

(g) The entire team will be **penalised by 05 marks per person**, in case the number of participants exceeds or are less than the limit laid down. Hence minimum and maximum strength of each event must be adhered to.

(h) Girl Cadets will wear only plastic bangles during competitions.

(j) Directorate will be liable to imposition of penalty in case of undue delay in presentation of their item. Such penalty will be imposed at the discretion of the Chief Judge (Presiding Officer of the Bd of Officer). **However, 10 minutes to include 03 minutes to clear the Stage and 07 minutes to set up, will be allowed before consideration for penalty.**

(k) Garments worn under the 'GHAGHRA' should preferably be of the same colour as that of the 'GHAGHRA'.

7. **Submission Of Nominal Rolls And Synopsis.** Directorates will submit the nominal roll of their teams for each competition in triplicate to the OIC Competitions, Delhi Dte and Judges 72 hours in advance of the competition.

8. Synopsis of all events in Hindi and English will also be handed over to Cultural Officer for submitting to the judges prior to the competitions.

9. Directorates will ensure that cadets are given requisite coaching and are deputed by name to read out the theme of the item being presented by their respective Directorates.

10. Any changes in the composition of teams due to unforeseen circumstances will be considered only on the written request of the Contingent Commander giving reasons for such a change. Till the Chief Judge approves it, no change will be accepted.

11. **Board of Officers/Judges.** A Board of Officers nominated by HQDGNCC will judge the competitions. DDG (MS) will approve the composition of the Board of Officers. DDG (MS) will also be an observer to oversee the conduct of the competitions and shall give on the spot decisions in case of any dispute/protest. His decision will be final.

12. **Declaration of the Results.** Results of each event will be finalized and signed by the Board of Officers/Judges. These will be announced after due approval of DGNCC.

### 13. Musical Instruments and Stage Décor.

(a) Contingents will bring their own musical instruments, dress and other accoutrements required for their performance. In this regard the Directorate may contact their State Cultural representative in Delhi for necessary assistance.

(b) Other arrangements necessary for conduct of the competitions on all days will be made by Officer In-charge Cultural Delhi Dte who will be assisted by male and lady ANOs. In addition, two GCIs and two JCOs/NCOs will assist in communications on stage. Light & signal equipment will be arranged by OC Camp.

(c) 'Diyas' and similar flammable materials / props will not be used as there are fire hazards. No Smoke is permitted.

### 14. Administrative Arrangements.

(a) All administrative arrangements for the competition on all days like provisioning of tables, chairs, glasses, water etc., will be made by the Camp Commandant, NIC. He will also be responsible for providing light refreshments to cadets outside the Auditorium.

(b) Arrangement of Heaters, if required for the Cadets outside the Auditorium.

(c) Delhi Directorate will be responsible for flower arrangements and stage decorations.

## RULES FOR INTER DIRECTORATE CULTURAL COMPETITION DURING NIC – II, DELHI

### 15. Group Song.

(a) Time - 4 Min + 1Min (Max 05 Minutes)

(b) Group - Minimum number of cadets - 07 Maximum number of cadets - 10 (including musicians on stage or in the background)

(c) Dress - Appropriate

(d) Language - Hindi / English / Regional

(e) Points Allotted :-

(i) Group Composition and Dress - 10

(ii) Renderings and composition - 12

(iii) Lyrics and composition - 12

(iv) Tune - 10

(v) Presentation - 06

**Total - 50**

(f) No dance of any type is permitted in this event.

### 16. Ballet / Dance.

(a) Time - 5 Min + 1 Min (Max 06 Minutes)

(b) Group - Minimum number of cadets – 04 (Excluding musicians on stage or in the background)

(c) Music and Instruments - Can be live or recorded.

(d) Stage Décor - No professional or hired arrangements will be allowed.

(e) Points Allotted :-

(i) Theme - 08

(ii) Presentation including costumes - 15

(iii) Composition, Synchronization & Skill - 20

(iv) Music and Background sound - 07

**Total - 50**

**INTER DIRECTORATE R&V EQUESTRIAN COMPETITIONS**

1. **General:** The following Inter Directorate R&V Equestrian Competitions will be held during DGNCC RD Camp to assess the equestrian training and skills of the cadets as well as the horses.

<b><u>Ser No</u></b>	<b><u>Events</u></b>	<b><u>Category</u></b>
1.	Dressage	(a) Boys Veteran (b) Boys Novice (c) Girls Veteran (d) Girls Novice
2	Show Jumping ( Normal)	(a) Boys Veteran (b) Boys Novice (c) Girls Veteran (d) Girls Novice
3.	Show Jumping (Top Score)	(a) Boys Veteran (b) Boys Novice
4.	Tent Pegging	(a) Boys Veteran (b) Boys Novice
5	Hacks	(a) Boys Veteran (b) Boys Novice (c) Girls Veteran (d) Girls Novice
6	Dr Roop Jyoti Sharma Trophy	Best Tent Pegger
7	DG RVS Cup	Best Show Jumper

2. The cadets and the horses for participation in the Annual NCC horse show will be selected based on the performance during the above competitions.

3. **Venue:** The competitions will be held during Annual NCC RD Camp at Delhi before Annual NCC Horse Show at the venue provisioned by HQ DGNCC.

4. **Jury:** Suitable jury comprising of RVC Officers/JCOs will be detailed by HQ DGNCC in consultation with Dte Gen RVS for judging the competitions.

5. **Participants:** Boys and Girls cadets (Novices and Veterans) from R&V NCC units will participate in these competitions. An R&V cadet can attend maximum of two RD camps as SD/SW but should preferably participate in Novice Competitions in his or her first RD Camp and in veteran events during second RD Camp. However, if an R&V cadet takes part in veteran in his or her first RD Camp itself then he or she will not be allowed to participate in Novice/Veteran events during next RD Camp. Hence, a cadet will not take part in the same event of the same category more than once.

**Best Rider**

6. **Categories:** A best rider will be selected for the following categories:-

- (a) Best Rider (Boys)

- (b) Best Rider (Girls)
- (c) Best Tent Pegger (Boys)
- (d) Best Show Jumper (Open)

7. **Selection Criteria:** The Jury will decide the best rider for above categories as per the criteria below:

- (a) **Best Rider (Boys):**The basis for judging the best rider (Boys) will be the highest aggregate points secured by each rider in the following individual competitions as per details below:

<u>Ser No</u>	<u>Event</u>	<u>Position and Points Allotted</u>			
		I	II	III	IV
(i)	Show Jumping (Normal)	4	3	2	1
(ii)	Show Jumping (Top Score)	4	3	2	1
(iii)	Tent Pegging	4	3	2	1
(iv)	Dressage	4	3	2	1

- (b) **Best Rider (Girls):** The basis for judging the best rider (Girls) will be the highest aggregate points secured by each rider in the following individual competitions as per details below:

<u>Ser No</u>	<u>Event</u>	<u>Position and Points Allotted</u>			
		I	II	III	IV
(a)	Show Jumping (Normal)	4	3	2	1
(b)	Dressage	4	3	2	1

- (c) **Best Tent Pegger (Boys) {Dr.Roop Jyoti Sharma Trophy}:** Best four riders each from Tent pegging Boys (Veteran)and Tent Pegging Boys (Novice) will be permitted to take part in the best tent pegger competition.

- (d) **Best Show Jumper (DG RVS Cup):**Best four cadets from each of the following equestrian competitions will be selected and permitted to take part in best show jumper competition:

- (i) Show Jumping(Normal) Boys (Veteran)
- (ii) Show Jumping (Normal)Boys (Novice)
- (iii) Show Jumping (Normal) Girls (Veteran)
- (iv) Show Jumping (Normal) Girls (Novice)
- (v) Show Jumping (Top Score) Boys (Veteran)
- (vi) Show Jumping (Top Score) Boys (Novice)

8. **Hacks Competition:** In this competition horsemanship of cadets and understanding with their horses and their turn out will be assessed.

9. **Dressage**: In this competition, the training of the cadets and their mounts is judged in dressage arena where they perform a series of predesignated movements or a dressage test.

10. **Appeal Committee**: The following will constitute the appeal committee: -

- (a) DDG (Training).
- (b) JD Trg (R&V)/OIC (R&V).

11. **Rules**:

- (a) The competitions will be judged and conducted in accordance with the rules and regulations of the Equestrian Federation of India.
- (b) A horse can take part only once in any particular event of that category.
- (c) Individual equestrian competitions will also act as elimination rounds for cadets to be eligible to take part in the competitions for trophies and cups.

12. **Dress Code**: All competitors must be properly dressed in a mounted kit for practice and for participating in various competitions. The cadets' dress will be as under:

- (a) Black Riding Helmet (Mandatory while being with the horses)
- (b) Red T shirt Woollen, round neck, Half sleeves
- (c) Breeches white
- (d) Knitted gloves white
- (e) Whips for competitions, if permitted
- (f) Black legging or black boots
- (g) NCC Blazer as per event

13. Only sound/fit horses will be permitted to participate in the equestrian events. Horses will be properly turned out and the harness and saddle will be of good quality to ensure the safety of the cadets and the horses. The important components of the tack are listed below:

- (a) Saddle – suitable for the event
- (b) Saddle Blanket/Numnah
- (c) Towels white with NCC colour Border 2” wide with the words ‘NCC’ of 2.5” size in red on both sides
- (d) Properly fitted Head Collar with suitable bit and reins
- (e) Other suitable harness items as per rules

14. **Jumps**: Nominated Directorates will send well maintained Jumps as per list below for use during RDC Equestrian Competitions: -



- (a) Road Closed
- (b) Single Bar
- (c) Double Bar
- (d) Triple Bar
- (e) Double Vertical Bar
- (f) Triple Vertical Bar
- (g) Rusting Gate
- (h) Wall
- (j) Brush

## NCC SONG "HUM SAB BHARTIYA HAIN"

Hum Sab Bhartiya Hain, Hum Sab Bhartiya Hain.

Apni Manzil Ek Hai, Ha, Ha, Ha, Ek Hai, Ho, Ho, Ho, Ho, Ek Hai.

Hum Sab Bhartiya Hain

Kashmir Ki Dharti Rani Hai

Sartaj Himalaya Hai

Sadiyon Se Hamne Isko Apne Khoon Se Pala Hai

“Desh Ki Raksha Ki Khatir Hum Shamshir Utha Lenge,

Hum Shamshir Utha Lenge

Bikhre-Bikhre Tarey Hain Hum Lekin Jhilmil Ek hai

Ha, Ha, Ha, Ha, Ek Hai

Hum Sab Bhartiya Hain

Mandir Gurudwara Bhi Hain Yahan

Aur Masjid Bhi Hai Yahan

Girja Ka Hai Ghadiyal Kahin

Mullah Ki Kahin Hai Ajaan

Ek Hi Apna Ram Hai, Ek Hi Hai Allah Taala Hai,

Ek Hi Allah Taala Hai, Rang Birange Deepak Hain Hum,

Ek Jagmag Ek Hai Ha, Ha, Ha, Ek Hai, Ho, Ho, Ho, Ek Hai,

Hum Sab Bhartiya Hain, Hum Sab Bhartiya Hain.